

YEARS: 2012-CURRENT

MAKE: KIA

MODEL: RIO 5

STYLE: HATCHBACK

WARNING: NEVER EXCEED YOUR VEHICLE MANUFACTURER'S RECOMMENDED TOWING CAPACITY
 For more information log onto www.curtmfg.com & for helpful towing tips log onto www.hitchinfo.com

WEIGHT CARRYING:
 TRAILER WEIGHT: 2,000 LBS.
 TONGUE WEIGHT: 200 LBS.

WARNING:
 ALL NON-TRAILER (WHEEL-LESS) LOADS APPLIED TO THIS PRODUCT MUST BE SUPPORTED BY 18050 STABILIZING STRAPS. PLEASE SEE THE CURT CATALOG OR VISIT US ONLINE AT WWW.CURTMFG.COM FOR FURTHER INFORMATION.

PRO INSTALL TIME: 25 MIN.
NOVICE INSTALL TIME: 50 MIN.

IF YOU ARE HESITANT TO UNDERTAKE THIS TASK ON YOUR OWN, CONTACT AN AUTHORIZED CURT INSTALLER FOR ADDITIONAL ASSISTANCE.

- INSTALLATION TIPS:**
- BEFORE YOU BEGIN INSTALLATION, READ ALL INSTRUCTIONS THOROUGHLY.
 - TO EASE INSTALLATION, 2 PEOPLE MAY BE REQUIRED.
 - USING PROPER TOOLS WILL GREATLY IMPROVE THE QUALITY OF THE INSTALL AND REDUCE THE TIME REQUIRED.
 - NEED HELP OR HAVE SOME QUESTIONS? CALL TECHNICAL SUPPORT AT 877.287.8634



INSTALLATION REQUIRES:

| | | |
|--|----------------|--------------------------------------|
| 10mm 11/16" 3/4" SOCKET | RATCHET | PHILLIPS SCREW DRIVER |
| TORQUE WRENCH | PRY BAR | SAFETY GLASSES |
| | | |
| | | |

LEVEL OF DIFFICULTY: EASY

| EASY | MODERATE | CHALLENGING |
|-----------------------|----------|-------------|
| -NO DRILLING REQUIRED | | |
| -FISHWIRE HARDWARE | | |
| -LOWER EXHAUST | | |
| | | |
| | | |

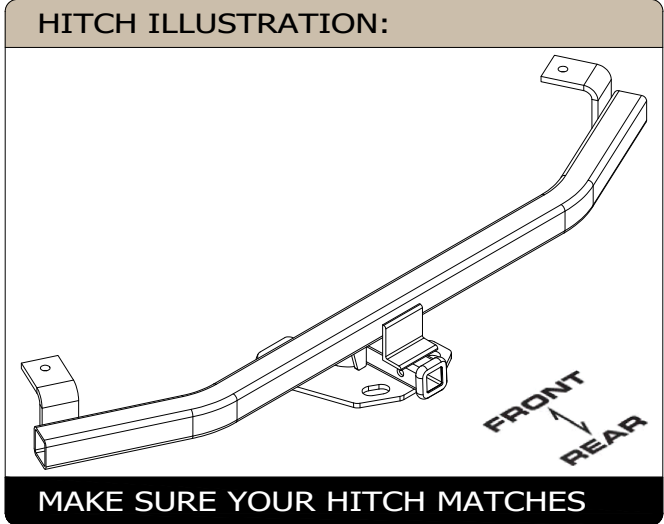

PERIODICALLY CHECK THIS RECEIVER HITCH TO ENSURE ALL FASTENERS ARE TIGHT AND ALL STRUCTURAL COMPONENTS ARE SOUND
 CURT Manufacturing LLC. warrants this product to be free of defects in material and/or workmanship at the time of retail purchase by the original purchaser. If the product is found to be defective, CURT Manufacturing LLC. may repair or replace the product at their option, when the product is returned, prepaid, with proof of purchase. Alteration to, misuse of, or improper installation of this product voids the warranty. CURT Manufacturing LLC.'s liability is limited to repair or replacement of products found to be defective, and specifically excludes liability for incidental or consequential loss or damage.
For more information log onto www.curtmfg.com
 This product complies with safety specifications and requirements for connecting devices and towing systems of the state of New York, V.E.S.C.Regulation V-5 and SAE J684.

SCAN FOR MORE INFO

INSTALLATION WALKTHROUGH:

| Parts List | | | |
|------------|-----|---------------|---|
| ITEM | QTY | PART NUMBER | DESCRIPTION |
| 1 | 1 | 10-10272 | BOLT, CAR, 1/2-13 UNC, 1-3/4, GRD8, YZ |
| 2 | 1 | CM-SP53 | .250 x 1.50 x 3.00" SQUARE HOLE SPACER |
| 3 | 1 | 20-00062 | NUT, SER-FLANGE, 1/2-13 UNC, GRD8, YZ |
| 4 | 2 | 10-10282 | BOLT, CAR, 7/16-14 UNC, 1-1/2, GRD8, YZ |
| 5 | 2 | CM-SP2 | .250 x .88 x 2.25" SQUARE HOLE SPACER |
| 6 | 2 | 20-00103 | NUT, SER-FLANGE, 7/16-14 UNC, GRD8, YZ |
| 7 | 2 | 7_16 FISHWIRE | 7/16" FISHWIRE |

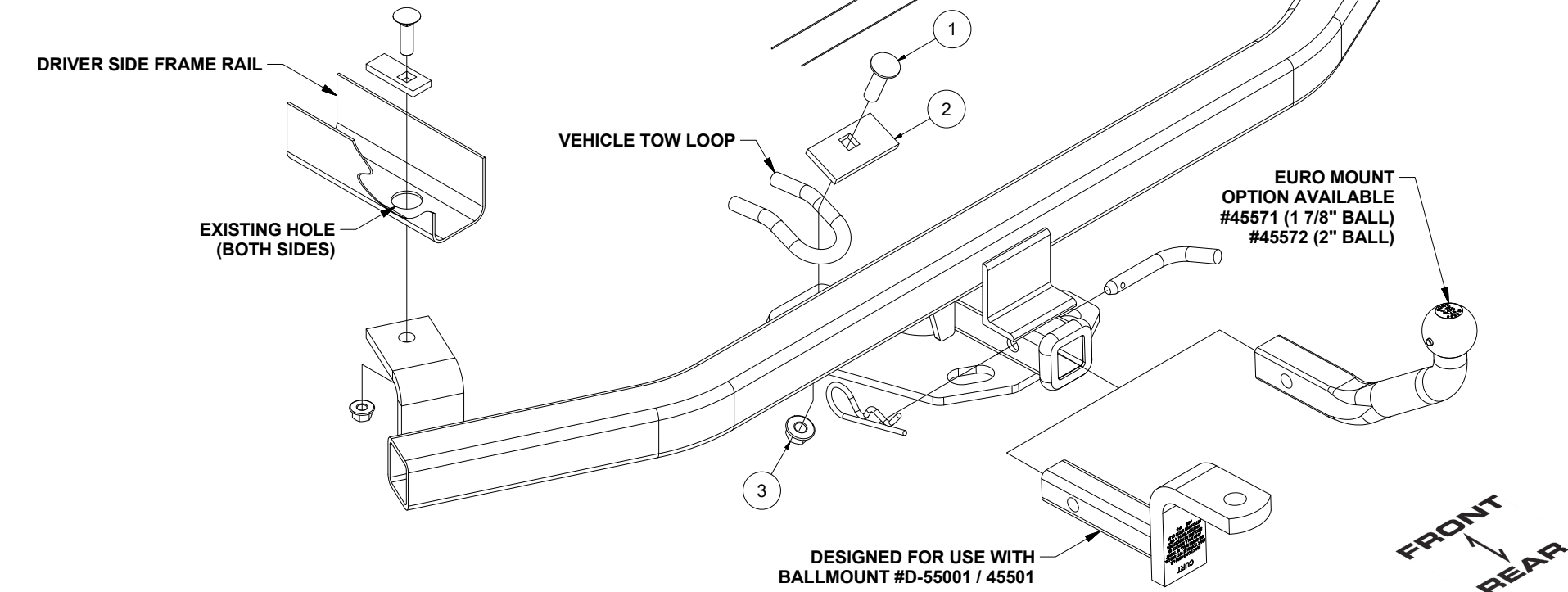
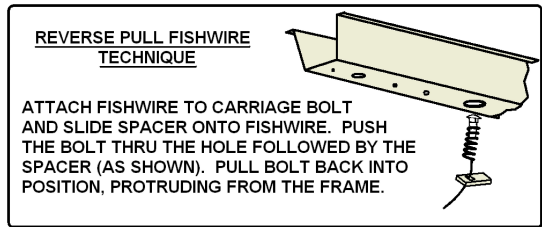
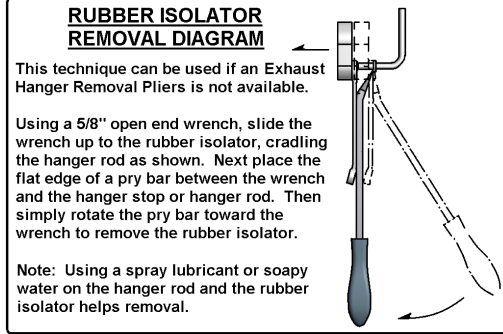

INSTALLATION WALKTHROUGH:

1. Temporarily remove plastic underbody panel by removing three phillips head plastic fasteners and three nuts.

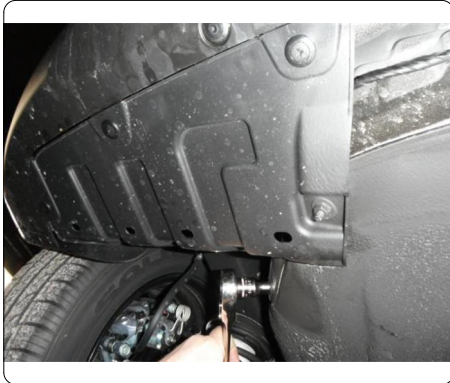

2. Lower exhaust by removing two rubber exhaust hangers. (See RUBBER ISOLATOR REMOVAL DIAGRAM on page 2)

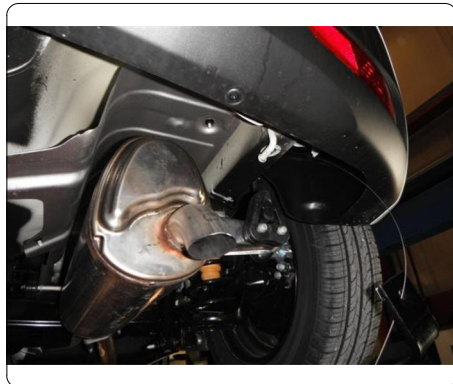

3. Remove one rubber plug from each frame rail and return to vehicle owner.

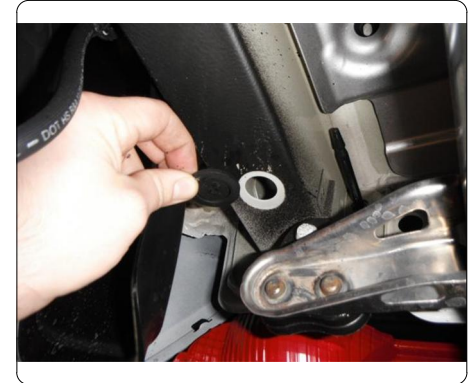

4. Reverse fishwire a 7/16" carriage bolt with a CM-SP2 spacer into each hole which a plug was removed from in step 3. (See REVERSE PULL FISHWIRE TECHNIQUE on page 2) **Note:** Leave fishwires attached to prevent loss of hardware inside frame.

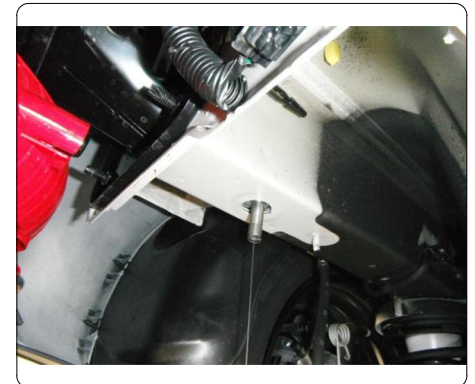
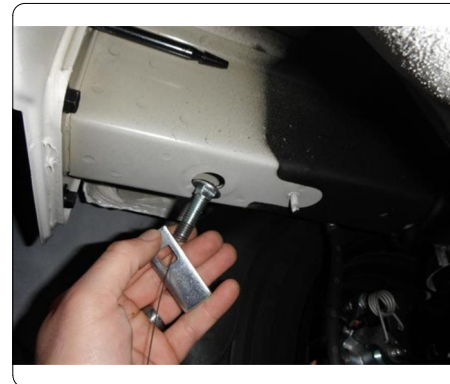

INSTALLATION WALKTHROUGH:

5. Insert 1/2" carriage bolt with CM-SP53 spacer through the top of the tow loop, as shown.



6. Raise hitch into position and secure hitch to tow loop with 1/2" flange nut. Remove fishwires and attach 7/16" hex flange nuts.



7. Torque all 7/16" hardware to 70 ft-lbs and all 1/2" hardware to 110 ft-lbs.

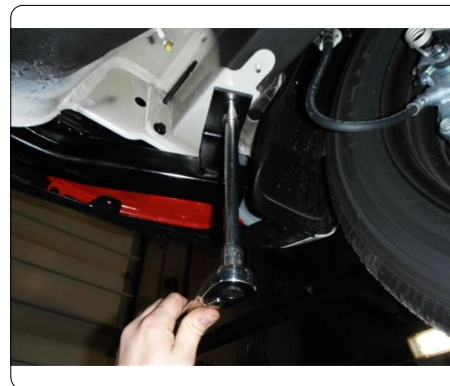

8. Reinstall the plastic underbody panel and the exhaust.
Install is complete.

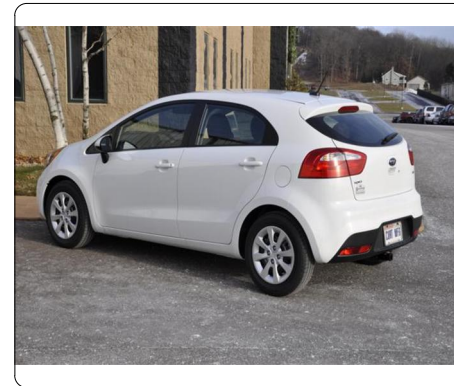
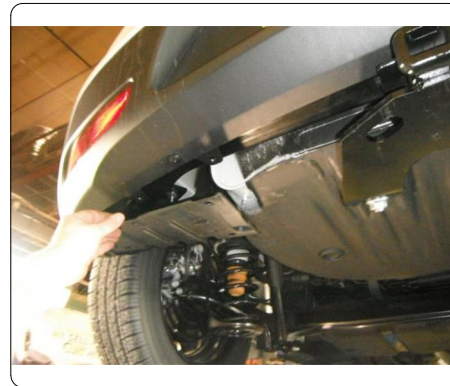

11262

KIA RIO 5

9/15/2020

GROSS LOAD CAPACITY WHEN USED AS A WEIGHT CARRYING HITCH: 2,000 LBS. TRAILER WEIGHT & 200 LBS. TONGUE WEIGHT.

*****DO NOT EXCEED VEHICLE MANUFACTURER'S RECOMMENDED TOWING CAPACITY.*****

WARNING: ALL NON-TRAILER LOADS APPLIED TO THIS PRODUCT MUST BE SUPPORTED BY 18050 STABILIZING STRAPS.

**** FAILURE TO PROPERLY SUPPORT NON-TRAILER LOADS WILL VOID PRODUCT WARRANTY****

HAVING INSTALLATION QUESTIONS? CALL TECHNICAL SUPPORT AT 877-287-8634

| Parts List | | | |
|------------|-----|---------------|--|
| ITEM | QTY | PART NUMBER | DESCRIPTION |
| 1 | 1 | 10-10272 | BOLT,CAR,1/2-13 UNC,1-3/4,GRD8,YZ |
| 2 | 1 | CM-SP53 | .250 x 1.50 x 3.00" SQUARE HOLE SPACER |
| 3 | 1 | 20-00062 | NUT, SER-FLANGE,1/2-13 UNC,GRD8,YZ |
| 4 | 2 | 10-10282 | BOLT,CAR,7/16-14 UNC,1-1/2,GRD8,YZ |
| 5 | 2 | CM-SP2 | .250 x .88 x 2.25" SQUARE HOLE SPACER |
| 6 | 2 | 20-00103 | NUT,SER-FLANGE,7/16-14 UNC,GRD8,YZ |
| 7 | 2 | 7_16 FISHWIRE | 7/16" FISHWIRE |

RUBBER ISOLATOR REMOVAL DIAGRAM

This technique can be used if an Exhaust Hanger Removal Pliers is not available.

Using a 5/8" open end wrench, slide the wrench up to the rubber isolator, cradling the hanger rod as shown. Next place the flat edge of a pry bar between the wrench and the hanger stop or hanger rod. Then simply rotate the pry bar toward the wrench to remove the rubber isolator.

Note: Using a spray lubricant or soapy water on the hanger rod and the rubber isolator helps removal.

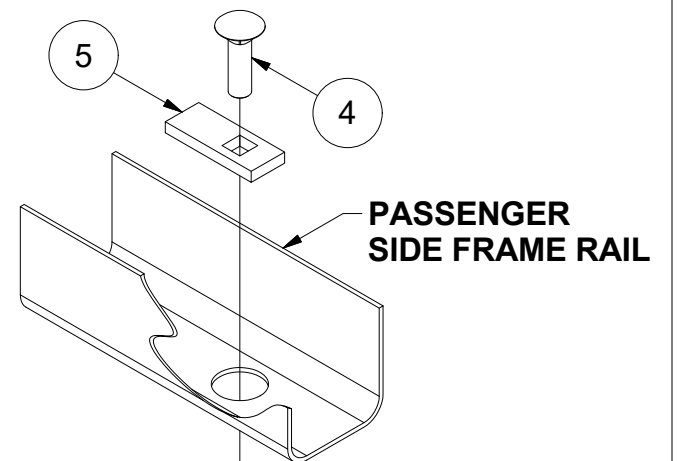
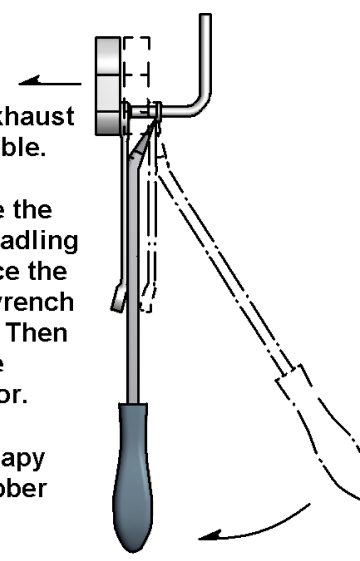

PASSENGER SIDE FRAME RAIL

REVERSE PULL FISHWIRE TECHNIQUE

ATTACH FISHWIRE TO CARRIAGE BOLT AND SLIDE SPACER ONTO FISHWIRE. PUSH THE BOLT THRU THE HOLE FOLLOWED BY THE SPACER (AS SHOWN). PULL BOLT BACK INTO POSITION, PROTRUDING FROM THE FRAME.

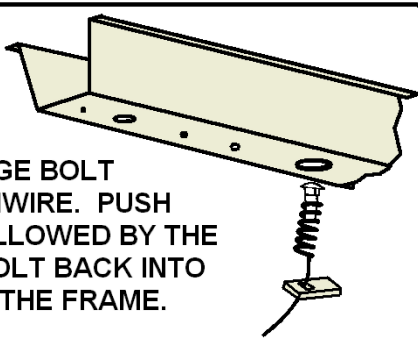

FRONT
REAR

DRIVER SIDE FRAME RAIL

VEHICLE TOW LOOP

EXISTING HOLE (BOTH SIDES)

EURO MOUNT
OPTION AVAILABLE
#45571 (1 7/8" BALL)
#45572 (2" BALL)

DESIGNED FOR USE WITH
BALLMOUNT #D-55001 / 45501

TOOLS REQUIRED

PHILLIPS SCREWDRIVER
10mm, 11/16", 3/4" SOCKETS
RATCHET
TORQUE WRENCH
PRY BAR

HITCH WEIGHT: 35 LBS.

INSTALL TIME

PROFESSIONAL: 25 MINUTES

NOVICE (DIY): 50 MINUTES

INSTALL NOTES:

-NO DRILLING REQUIRED
-FISHWIRE HARDWARE
-LOWER EXHAUST

INSTALLATION STEPS

1. Temporarily remove plastic underbody panel by removing three phillips head plastic fasteners and three nuts.
2. Lower exhaust by removing two rubber exhaust hangers. (See RUBBER ISOLATOR REMOVAL DIAGRAM above)
3. Remove one rubber plug from each frame rail and return to vehicle owner.
4. Reverse fishwire a 7/16" carriage bolt with a CM-SP2 spacer into each hole which a plug was removed from in step 3. (See REVERSE PULL FISHWIRE TECHNIQUE above) **Note:** Leave fishwires attached to prevent loss of hardware inside frame.
5. Insert 1/2" carriage bolt with CM-SP53 spacer through the top of the tow loop, as shown above.
6. Raise hitch into position and secure hitch to tow loop with 1/2" flange nut. Remove fishwires and attach 7/16" hex flange nuts.
7. Torque all 7/16" hardware to 70 ft-lbs and all 1/2" hardware to 110 ft-lbs.
8. Reinstall the plastic underbody panel and the exhaust.

PERIODICALLY CHECK THIS RECEIVER HITCH TO ENSURE THAT ALL FASTENERS ARE TIGHT AND THAT ALL STRUCTURAL COMPONENTS ARE SOUND.

Curt Manufacturing LLC., warrants this product to be free of defects in material and/or workmanship at the time of retail purchase by the original purchaser. If the product is found to be defective, Curt Manufacturing LLC., may repair or replace the product, at their option, when the product is returned, prepaid, with proof of purchase. Alteration to, misuse of, or improper installation of this product voids the warranty. Curt Manufacturing LLC.'s liability is limited to repair or replacement of products found to be defective, and specifically excludes liability for incidental or consequential loss or damage.