

Parts List

| | |
|----|---|
| 1 | Driver side / left side bar |
| 1 | Passenger side / right side bar |
| 2 | Mounting bracket, front |
| 2 | Mounting bracket, middle |
| 2 | Mounting bracket, rear |
| 2 | Hex bolt, 10mm x 30mm |
| 2 | Flat washer, 10mm x 25mm x 2mm |
| 2 | Lock washer, 10mm |
| 6 | Hex bolt, 12mm x 120mm (only for 00 - 06 models) |
| 4 | Hex bolt, 12mm x 50mm |
| 10 | Flat washer, 12mm x 35mm x 3mm |
| 10 | Lock washer, 12mm |

Level of Difficulty

Easy

Scan
for helpful
install tips**Product Image****Notes and Maintenance**

Before you begin installation, read all instructions thoroughly.

Proper tools will improve the quality of installation and reduce the time required.

To protect the product, wax after installing. Regular waxing is recommended to add a protective layer over the finish. Do not use any type of polish or wax that may contain abrasives that could damage the finish.

For gloss black finishes, mild soap may be used to clean the product.

Procedure

1. Begin installation by working on the driver-side of the vehicle, see figures 1 through 4.
2. From underneath truck, loosen and remove body mount bolts that run upward through mounts into floorboard.

Attach and secure front mount bracket to underside of the vehicles front body mount with one M12 - 1.75 x 120mm bolt (for 2007 models, use the factory bolt on the vehicle), one 12mm lock washer and one 12mm flat washer. See figure 2. Snug the hardware, but do not fully tighten.

3. Repeat step 2 to secure the rear (see figure 4) and middle (see figure 3) mounting brackets to the vehicle.
4. Attach the side bar to the front and rear brackets using one M12 x 50mm bolt, one 12mm lock washer and one 12mm flat washer for each bracket. Hand tighten.

Fasten the middle mounting bracket to side bar using one 10mm x 30mm bolt, one 10mm flat washer and one 10mm lock washer.

5. Adjust the side bar so that it is level and centered, and tighten all bolts to complete the driver-side assembly.
6. Repeat this process for the passenger-side of the vehicle.
7. Congratulations on the installation of your new ARIES 3" round side bars. With the side bars installed, periodic inspections should be performed to ensure all mounting hardware remains tight.

To protect your investment, see the 'Notes and Maintenance' section on the first page of this instruction manual.

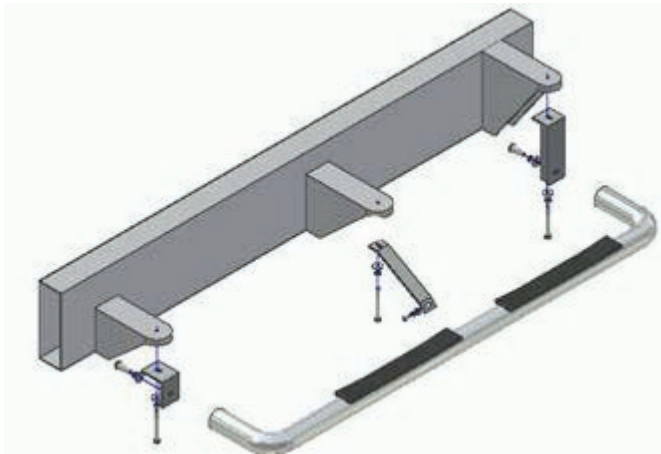

Figure 1 - Full assembly view, driver-side

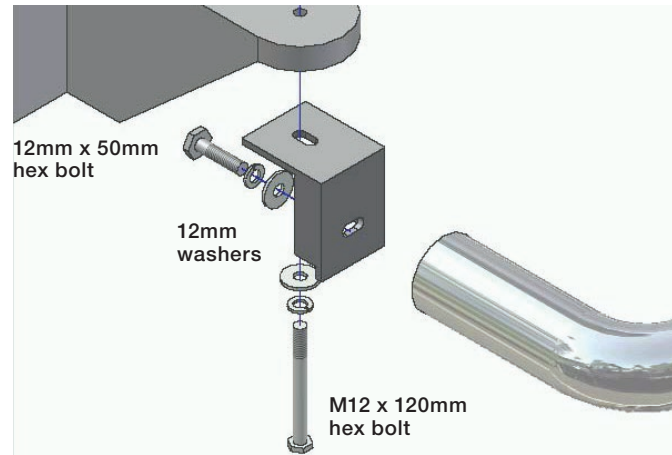

Figure 2 - Front bracket

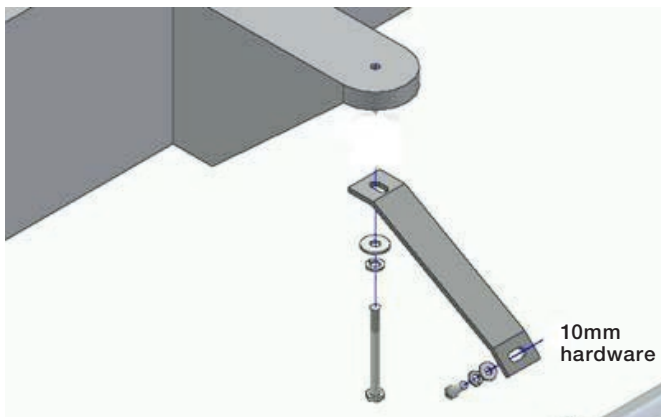

Figure 3 - Middle bracket

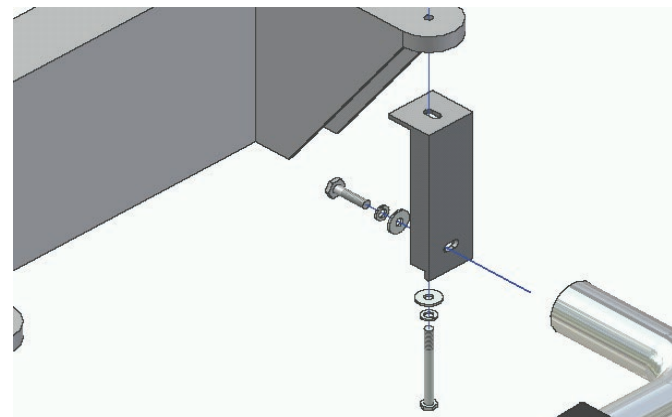

Figure 4 - Rear bracket

INSTALLTION ALERT

General Motors has made changes to their late model 2010 and 2012 Chevrolet Silverado and GMC Sierra Light Duty and Heavy Duty Trucks and these changes affect the installation of our Side Bars.

Currently, all Side Bars manufactured for GM trucks use the factory body mount bolts to attach the bars and brackets to the truck. In years past, GM used a fixed nut that was welded in place to the chassis of the truck. Starting late 2010, GM has now gone to a loose nut that is surrounded by a "Cage Nut" which has two tabs on either side of the nut to keep it from loosening. Along with this cage nut, GM is also using Heavy Duty Loc-tite on the Body Mount Bolts for added protection.

Due to this change, Aries is recommending **EXTREME CARE** when removing the factory body mount bolts from these trucks. **Loosen and re-tighten all body mount bolts by hand! DO NOT use Impact Tools of any kind!** If bolts become increasingly tight as you are loosening them you may need to retighten & loosen the bolt several times to clear the loc-tite from the threads Failure to follow this instruction could cause the body mount bolts to seize and the tabs of the 'Cage Nut' to bend allowing the nut to spin freely inside Chassis floor board!

Most of clients have been installing the existing side bar applications on these new trucks with no issues, but please be sure to follow our recommendation to prevent any installation issues. If you have any questions, please feel free to call our Customer Service Department at 888-800-2743.

