



INSTALLATION INSTRUCTIONS

PRO TRAXX 4 OVAL STEP BAR & PRO TRAXX 5 OVAL STEP BAR APPLICATION:

**2015-2017 Ford F-150 Super Cab / Super Crew
2017 Ford F-250/350 Super Cab / Crew Cab**

PART NUMBER:

**21-23930, 21-23935, 21-23940, 21-23945, 21-53930, 21-53935,
21-53940, 21-53945**

AUTOMOTIVE PRODUCTS,

ITEM	QUANTITY	DESCRIPTION	TOOLS NEEDED
1,2	2	SIDE STEP BAR, DRIVER(1) AND PASSENGER(2)	13MM SOCKET
3	4, 6*	UNIVERSAL SUPPORT BRACKET	SOCKET EXT.
4	2	“A” FRONT MOUNTING BRACKET	HEX KEY TOOL (INCLUDED)
5	2, 4*	“B” REAR MOUNTING BRACKET	
6	16, 24*	M8 HEX NUT (YELLOW ZINC)	RATCHET
7	16, 24*	M8 FLAT WASHER (YELLOW ZINC)	TORQUE WRENCH
8	16, 24*	M8 SPLIT LOCK WASHER (YELLOW ZINC)	
9	4, 6*	M8 CARRIAGE SQUARE NECK BOLT (BLACK ZINC)	
10	8, 12*	M10 INTERNAL TOOTHED LOCK WASHER (STAINLESS)	
11	8, 12*	M10 FLAT WASHER (STAINLESS)	
12	8, 12*	M10 BUTTON HEAD SCREW (STAINLESS)	
13	12, 18*	M8 PLASTIC RETAINER SQUARE	
14	4, 6*	PLASTIC BRACKET COVER	
15	8, 12*	M6 HEX HEAD CAP SCREW (YELLOW ZINC)	
16	16, 24*	M6 FLAT WASHER (YELLOW ZINC)	
17	8, 12*	M6 NYLON NUT (YELLOW ZINC)	

QUANTITY VARIES FOR SUPER CAB AND SUPER CREW. SUPER CREW QUANTITY HAS A (*) NEXT TO THE AMOUNT.

ANTI-SEIZE LUBRICANT MUST BE USED ON ALL STAINLESS STEEL FASTENERS TO PREVENT THREAD DAMAGE AND GALLING

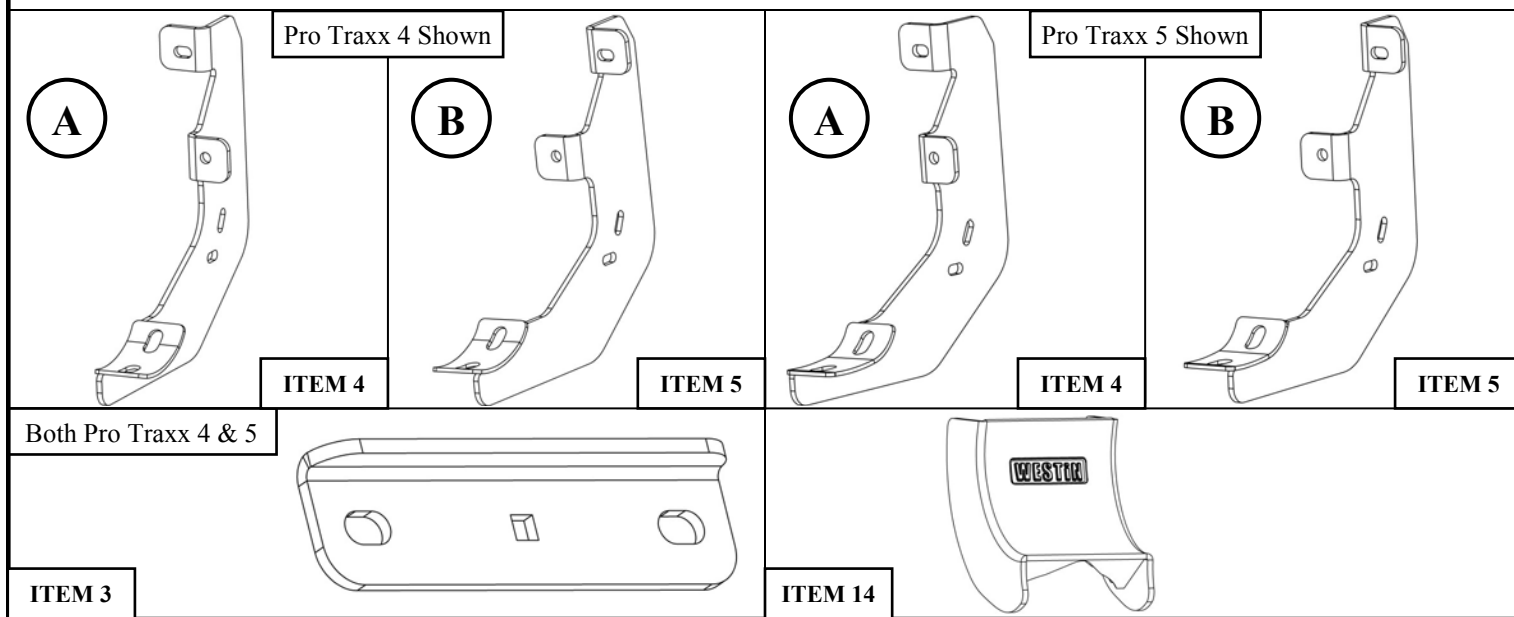

Westin Automotive Products, Inc.
320 W. Covina Blvd
San Dimas, Ca. 91773

PROCEDURE

1. Remove contents from box, verify if all parts listed are present and free from damage.

Carefully read and understand all instructions before attempting installation.

Failure to identify damage before installation could lead to a rejection of any claim.

2. Locate factory welded studs on the rocker panel. **See Fig. 1.**
3. Thread M8 square plastic poly retainer (Item 13) onto each factory studs for driver side. Repeat for passenger side. **See Fig. 2.** (**Note:** The plastic poly retainers are necessary to prevent reaction between supplied steel equipment and aluminum rocker panel.)

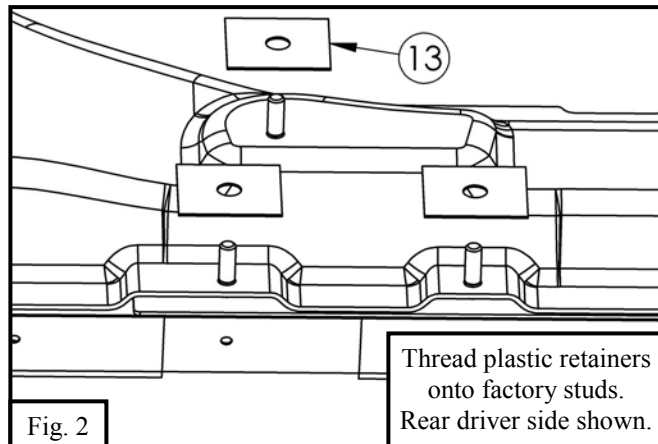
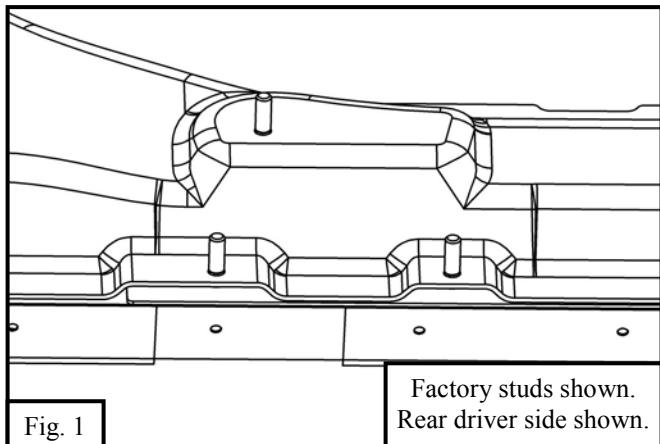

4. Loosely install the universal support brackets to all mounting brackets with supplied M8 carriage square neck bolt and M8 hardware. **See Fig. 3.** (**Note:** See **Fig. 7** and **Fig. 8** for placement of mounting brackets.)
5. Loosely install driver side mounting brackets to rocker panel with supplied M8 hardware. Repeat for passenger side. **See Fig. 4.**

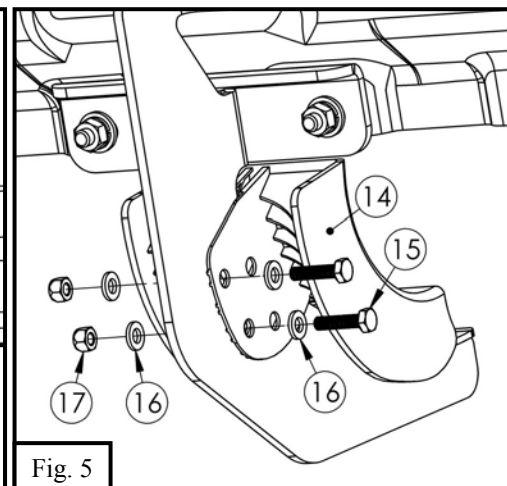
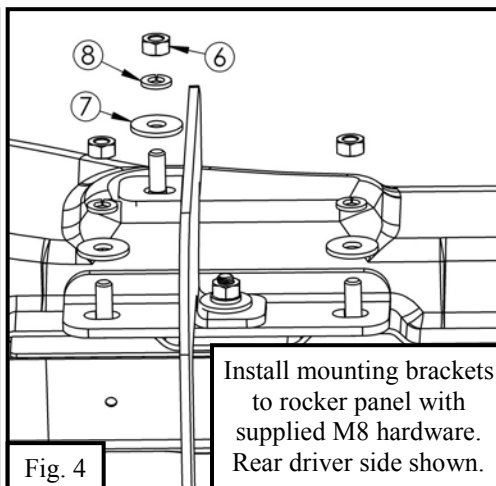
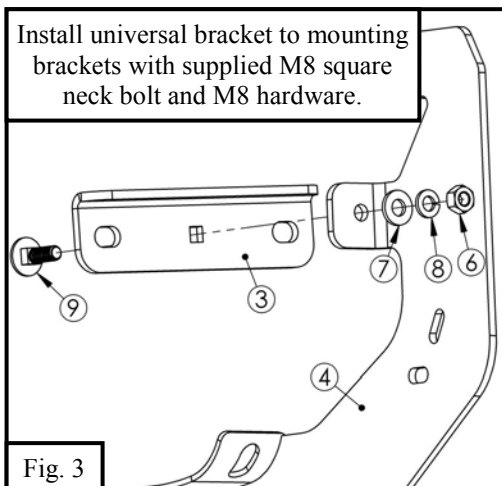

6. Locate (1) plastic bracket cover (Item 14) and loosely secure it to the (4/6) brackets using the provided hardware: (2) M6 hex head cap screws, (4) M6 flat washers, and (2) M6 nylon nuts. Repeat for every bracket. **See Fig. 5.**
7. Loosely install the Pro Traxx step bar assembly to the previously installed mounting brackets with the supplied M10 hardware. (**Note:** Driver side step tube will be packaged in a clear poly tube and passenger side will be packaged in a red poly tube, the Westin logo should face outward when installed.) **See Fig. 6.**
8. Align and adjust as necessary then torque hardware : M8 to 15-18 ft-lbs, M10 to 30-35 ft-lbs, and M6 to 7-8 ft-lbs.



Westin Automotive Products, Inc.
320 W. Covina Blvd
San Dimas, Ca. 91773

Thank you for choosing Westin products
for additional installation assistance please call
Customer Service (800) 793-7846
www.westinautomotive.com

Install step bar to mounting brackets with the supplied M10 hardware. Front driver shown.

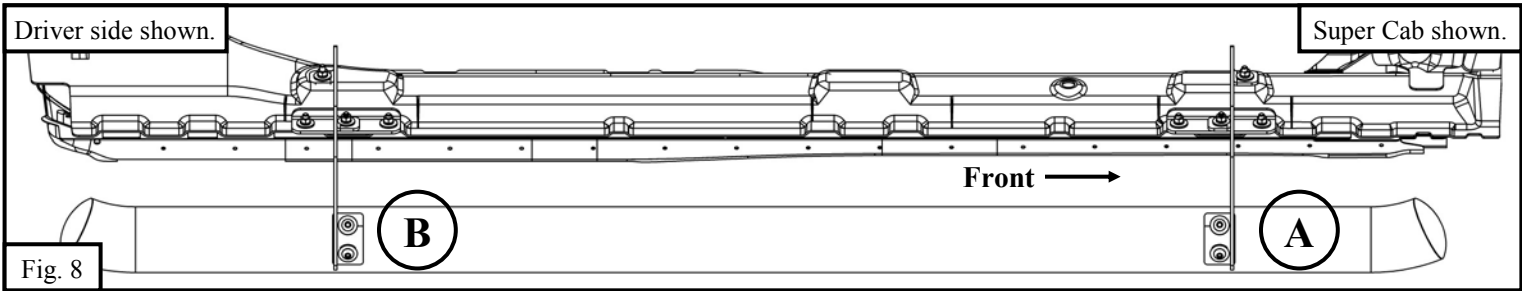
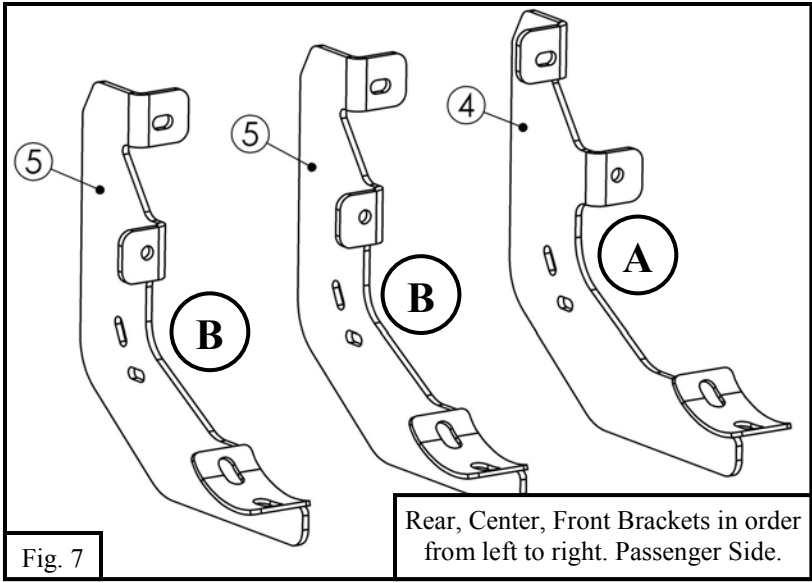
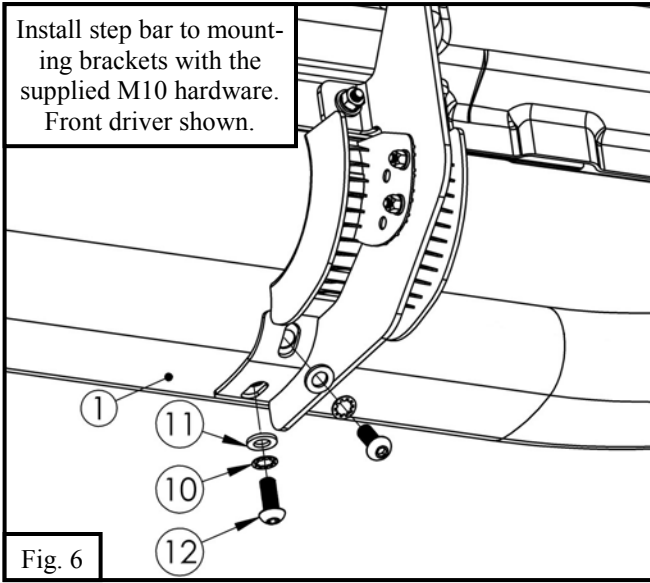

CARE INSTRUCTIONS

- REGULAR WAXING IS RECOMMENDED. DO NOT USE ANY TYPE OF POLISH OR WAX THAT MAY CONTAIN ABRASIVES.
- STAINLESS STEEL PRODUCTS CAN BE CLEANED WITH MILD SOAP AND WATER. STAINLESS STEEL POLISH SHOULD BE USED TO POLISH SMALL SCRATCHES.
- GLOSS BLACK FINISHES SHOULD BE CLEANED WITH MILD SOAP AND WATER.



Westin Automotive Products, Inc.
320 W. Covina Blvd
San Dimas, Ca. 91773

Thank you for choosing Westin products
for additional installation assistance please call
Customer Service (800) 793-7846
www.westinautomotive.com



SIGNATURE OF QUALITY

AUTOMOTIVE PRODUCTS, INC.



WARNING



Failure to follow these instructions could lead to death, personal injury, and / or property damage.

FASTENERS:

All Westin supplied fasteners must be utilized and installed in accordance with the installation instructions and apply torque to the specifications as defined. **DOUBLE CHECK ALL FASTENERS BEFORE INITIAL USE, AND PERIODICALLY IN THE FUTURE TO ENSURE PROPER FUNCTION AND SAFETY.**

DRILLING:

Most Westin products do not require drilling for installation. If drilling is defined as required, use caution when drilling a vehicle. **FAILURE TO REVIEW AN AREA TO BE DRILLED MAY RESULT IN PERSONAL INJURY AND/OR INJURY TO OTHERS AS WELL AS VEHICLE DAMAGE.**

EYE PROTECTION:

ALWAYS WEAR SAFETY GLASSES OR GOGGLES DURING THE INSTALLATION PROCESS TO AVOID PERSONAL INJURY.

MAXIMUM TOWING/CARRYING CAPACITY:

The Westin Receiver Hitches will have a visible tow rating label affixed directly on the product. User should never exceed the vehicle manufacturers maximum tow and weight rating regardless of the capacity of the hitch. **FAILURE TO FOLLOW THESE GUIDELINES WILL VOID THE WESTIN WARRANTY AND MAY RESULT IN PERSONAL INJURY AND/OR INJURY TO OTHERS AS WELL AS VEHICLE DAMAGE.**



Westin Automotive Products, Inc.
320 W. Covina Blvd
San Dimas, Ca. 91773