

I-SHEET PART NUMBER: INST-00282  
 PART NUMBER: **315418512**  
 PRODUCT: **RS HOOP STEP**  
 APPLICATION: **15-22 FORD F-150 CC**  
**17-22 FORD F-250/350 CC**

HARDWARE DESCRIPTION		QTY.
HWKT-00031X		
FLNT-00696X	M8-1.25 CLASS 8 SERRATED FLANGE NUT	18
FDRW-00736X	M8 FENDER WASHER	18
	10MM Carriage bolt	12
	10MM flanged nut	12
PARTS INCLUDED		QTY
DRIVER SIDE STEP		1
PASSENGER SIDE STEP		1
MOUNTING BRACKETS		6

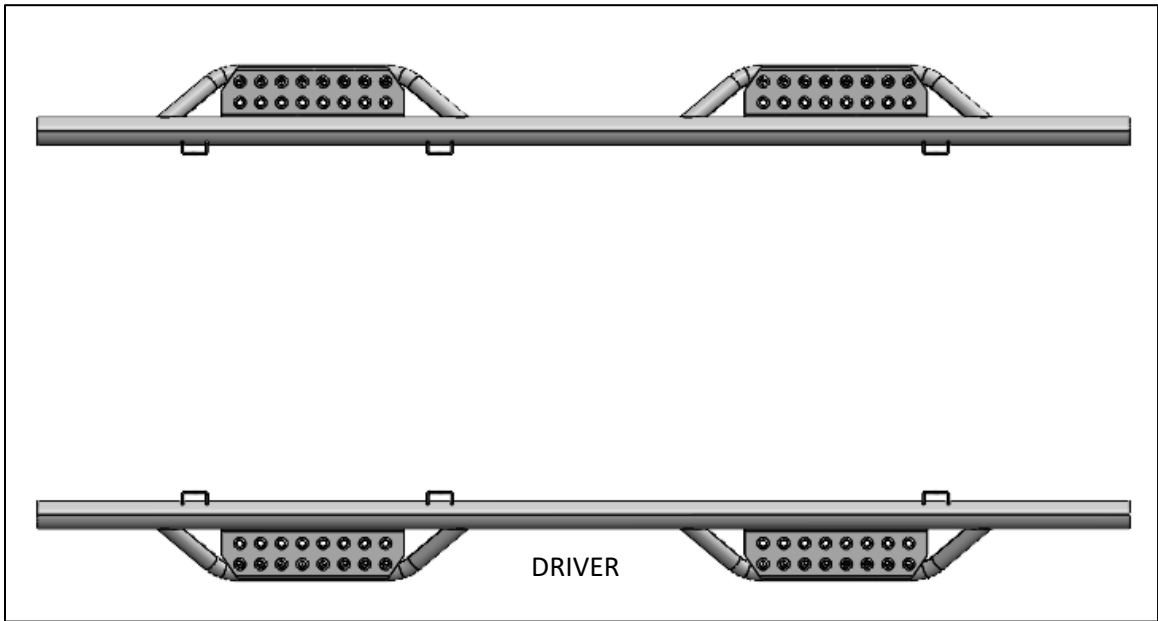

**Step 1.** Identify driver side step.



**Step 2.** Install the (x6) mounting brackets to each attachment point on the main tube using the supplied M10x25 carriage bolts, M10 hex nuts and leave loose for now. **Note the bracket orientation for driver and passenger.**

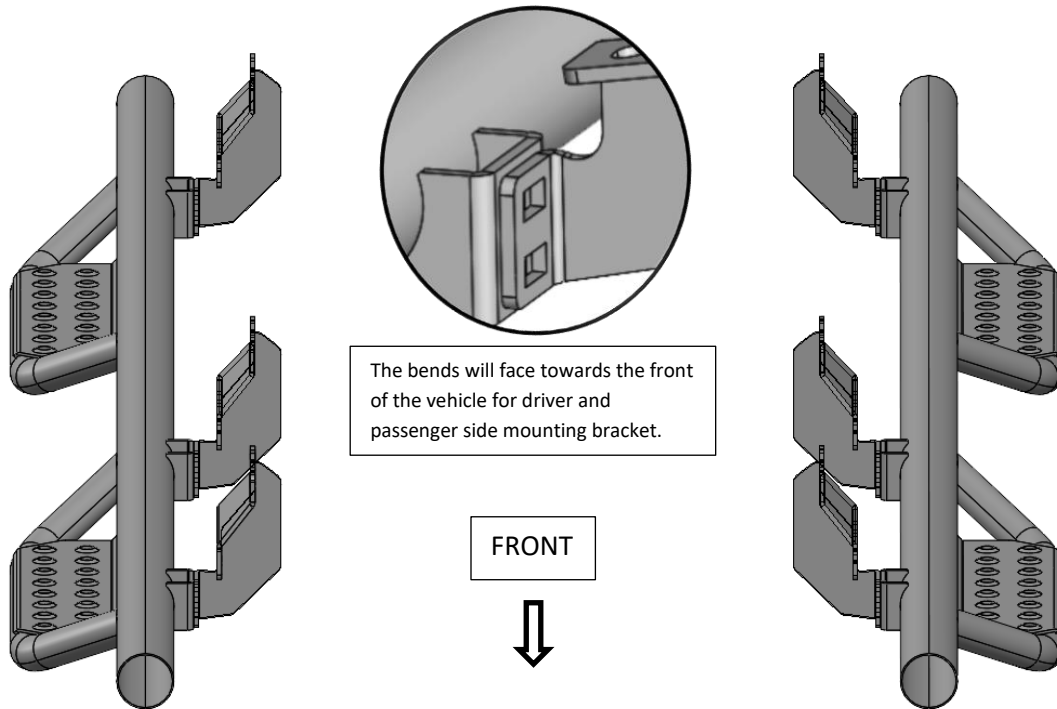

**Step 3.** Starting with the Driver Side. Remove all 8mm flange nuts from the 8mm factory threaded studs to remove the OE running boards.



**Step 4.** Next, carefully raise the step assembly into position and align the three brackets with the nine 8mm OE threaded studs.

**Step 5.** Using the supplied 8mm flanged nuts, fasten all nine mounting positions. Leave loose at this time.

**Step 6.** Beginning at the rear bracket, push upwards on the tube to align with the body then tighten only the lower rear fastener at this time.

**Step 7.** Next, move to the front bracket, push upwards on the tube to level with the body. Tighten all three fasteners.

**Step 8.** Tighten the remaining fasteners on the middle and rear bracket.



**Step 9.** Next, tighten brackets (x3) at the main tube.

**Step 10.** Repeat steps 2-9 for passenger side.

