

Parts List

1	Bull bar
2	Mounting bracket, universal
8	Hex bolt, M10
16	Flat washer, M10
8	Lock washer, M10
8	Hex nut, M10

Level of Difficulty

Easy

Scan
for helpful
install tips**Product Image****Notes and Maintenance**

Before you begin installation, read all instructions thoroughly.

Proper tools will improve the quality of installation and reduce the time required.

To protect the product, wax after installing. Regular waxing is recommended to add a protective layer over the finish. Do not use any type of polish or wax that may contain abrasives that could damage the finish.

For stainless steel and aluminum, polish may be used to clear small scratches and scuffs on the finish. Mild soap may be used also to clean the product.

Procedure

1. Determine passenger and driver brackets. See figure 3. Remove tow hooks. Keep fasteners for reinstallation.
2. Removal of center bumper filler panel is required for bracket installation. From backside of bumper use a small screwdriver to first push out the center body of rivet then the main body of rivet. Remove all rivets and filler panel.
3. Locate four holes on frame bracket. Position brackets to two holes closest to the outside of vehicle.

Note: 1500 models use two inside slots. 2500 / 3500 models use outside most slots. Vehicles with tow hooks use factory fasteners to attach brackets, otherwise use M10 fasteners. Leave loose. See figure 3.

4. Attach bull bar to brackets using M10 fasteners as shown. Make sure mount tabs on hoop are inside brackets. Leave loose. See figure 3.
5. Level and adjust bull bar as desired. Torque all M10 fasteners to 30 ft. lbs and tow hook fasteners to 65 ft. lbs.
6. Congratulations on the installation of your new ARIES 3" bull bar. With the bull bar installed, periodic inspections should be performed to ensure all mounting hardware remains tight.

To protect your investment, see the 'Notes and Maintenance' section on the first page of this instruction manual.

4,5,6,7

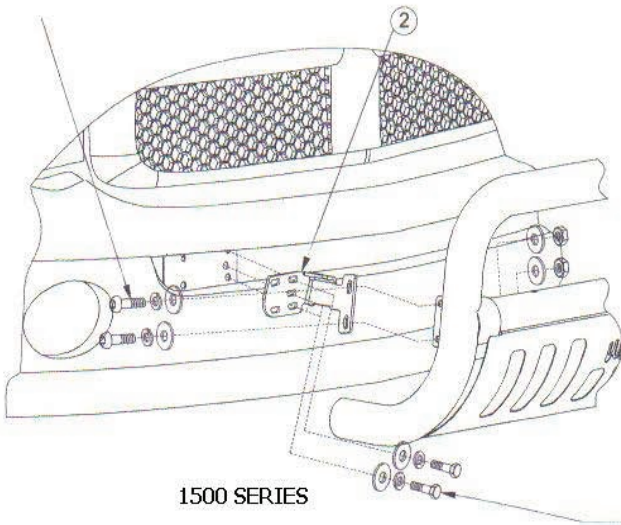

4,5,6,7

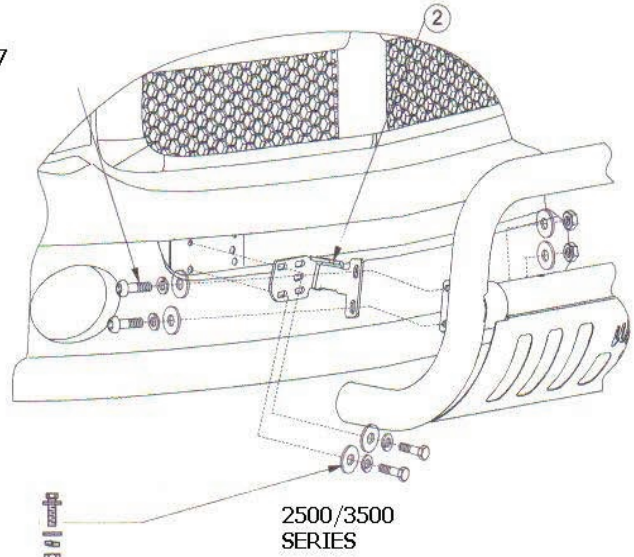

FIGURE 3-INSTALLATION VIEW OF PASSENGER SIDE, DRIVER SIDE OPPOSITE

