

Rancher Grille Guard
 Installation Instructions
46699
 Chevy Silverado 1500 HD '01 - '02
 Chevy Silverado 1500/2500 '99 - '02
 Chevy Suburban/Tahoe 1500/2500 '00 - '06

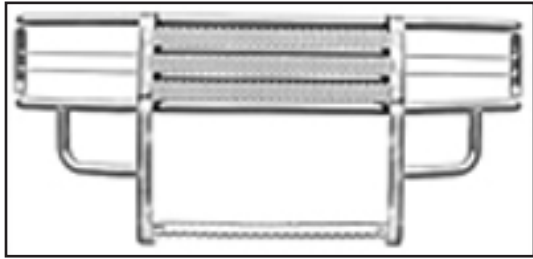

Diagram 1

Parts List:	
1 - Grille Guard #699	8 - 1/2" Flat Washers
2 - Top Brackets #499-5	4 - 1/2" Lock Washers
1 - Driver Bottom Bracket #699-7	4 - 1/2" Hex Nuts
1 - Pass. Bottom Bracket #699-8	2 - M12 x 50mm Bolts
2 - Threaded Plates #699-9	
4 - 1/2" x 1 1/2" Bolts	

Note: Completely read instructions before beginning installation!

1. Remove the contents from the box and check for missing pieces or damage. If parts are missing or damaged, contact the original place of purchase. Read the instructions completely before beginning. Two people are strongly recommended for this install.
2. Remove the Factory Radiator Cover and Factory Grille: Open the hood on the truck. Using Diagram 2, locate the factory radiator cover. To remove the pop rivets, use a flat head screwdriver to pull up on the middle of the pop rivets. To remove the bottom part of pop rivet, place the screwdriver under the bottom and push up. Repeat this procedure to remove all pop rivets. To remove the factory grille, place your hand behind grille and push out until the grille can be removed. Place the factory radiator cover, pop rivets and factory grille to the side to be re-installed later.
3. Install the Top Bracket #499-5 Driver and Passenger: Locate the Top Bracket #499-5 for installation at this time. Remove the factory bumper bolt as shown in Diagram 3. Place the Top Bracket #499-5 over the opening. Replace the factory bumper bolt through the top bracket and into the bolt hole opening. Hand tighten this bolt at this time. Repeat step "A" above on the passenger side to install the Passenger Top Bracket #499-5.

View of Factory Grille Removal

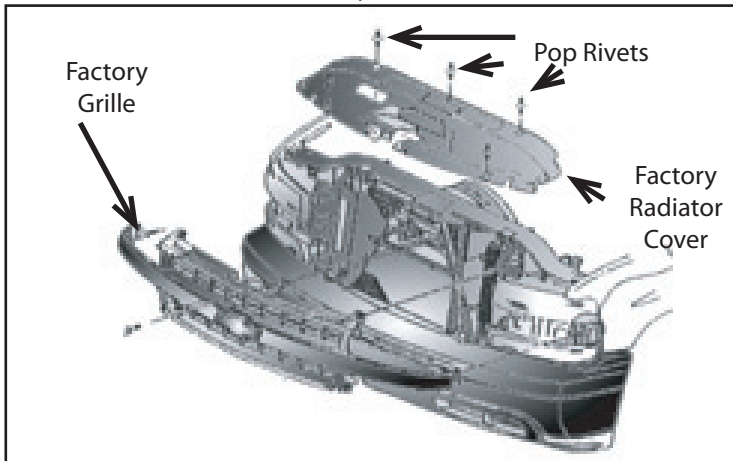

Diagram 2

Driver Side Top View of Top Bracket #499-5

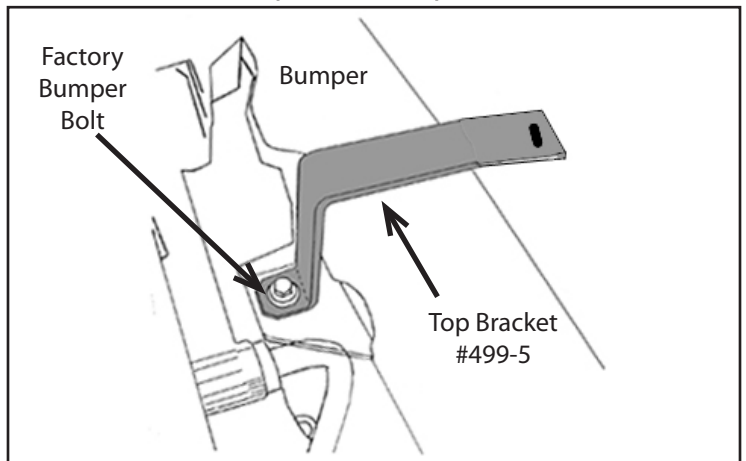

Diagram 3

Rancher Grille Guard
 Installation Instructions
46699
 Chevy Silverado 1500 HD '01 - '02
 Chevy Silverado 1500/2500 '99 - '02
 Chevy Suburban/Tahoe 1500/2500 '00 - '06

View of Frame with Bracket Placement

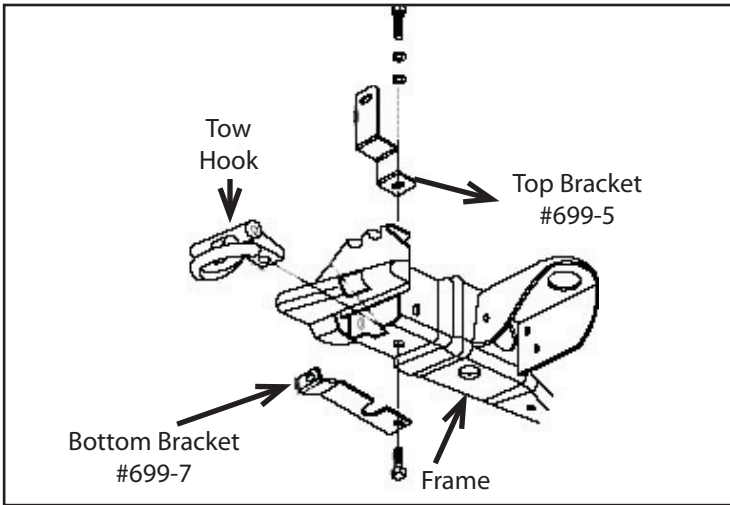

Diagram 4

View of 1500HD Frame with Bracket Placement

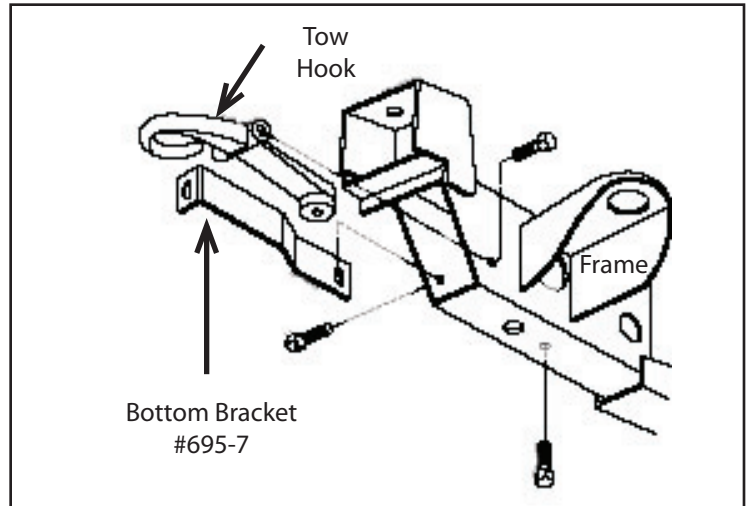

Diagram 5

4. For 1500 vehicles Install the Driver Bottom Brackets #699-7 and Passenger Bottom Brackets #699-8: Using Diagram 4, locate the driver bottom brackets #699-7 for installation at this time.

A. Vehicles with tow hooks: If the vehicle is equipped with tow hooks, locate the bottom bolt on tow hook. Loosen the bottom bolt and remove. Place flat end of driver bottom brackets #699-7 up to bottom bolt opening and replace the factory bolt with (1) M12 x 2" hex head bolt as shown in Diagram 4 and Diagram 5. Hand tighten all bolts at this time. Repeat above procedure for passenger bottom bracket #699-8.

B. Vehicles without tow hooks: If the vehicle is not equipped with tow hooks, the plastic spoiler must be cut out for the bottom bracket to pass through. Align the bottom bracket with the inside hole on the frame and place bottom bracket against the plastic spoiler and mark the area to be cut. Carefully cut a slot for the bottom bracket to pass through the spoiler to the Grille Guard. Use threaded plate #699-9 to take place of tow hook. Place bracket #699-9 to the inside of the frame and line up the threaded hole in the bracket #699-9 with the inside hole of frame. Place driver bottom bracket #699-7 up to frame use (1) 1/2" x 1 1/4" hex head bolt and attach bottom bracket to threaded plate. Hand tighten all bolts at this time. Repeat above procedure for passenger bottom bracket #699-8.

5. For 1500HD/2500 non HD Install the Driver Bottom Brackets #695-7 and Passenger Bottom Bracket #695-8: Using Diagram 5, locate the driver bottom brackets #695-7 for installation at this time.

A. Vehicles with tow hooks: If the vehicle is equipped with tow hooks, locate the inside bolt on tow hook. Loosen the inside bolt and remove. Place flat end of driver bottom brackets #695-7 up to inside bolt opening and replace the factory bolt with (1) M12 x 50mm hex head bolt as shown in Diagram 7. Hand tighten all bolts at this time. Repeat above procedure to install passenger bottom bracket #726-8.

B. Vehicles without tow hooks: If the vehicle is not equipped with tow hooks, the plastic spoiler must be cut out for the bottom bracket to pass through. Align the bottom bracket with the inside hole on the frame and place bottom bracket against the plastic spoiler and mark the area to be cut. Carefully cut a slot for the driver bottom bracket #695-7 to pass through the spoiler to the Grille Guard. Place bracket #699-9 to the inside of the frame and line up the threaded hole in bracket #699-9 with the inside hole of frame. Place driver bottom bracket #695-7 up to frame use (1) 1/2" x 1 1/2" hex head bolt and attach bottom bracket to threaded plate. Hand tighten all bolts at this time. Repeat above procedure to install passenger bottom bracket #695-8.

6. Attach the Grille Guard to the mounting brackets: Using two people align the Grille Guard holes to the top brackets. Attach the Grille to the top brackets using (1) 1/2" x 1 1/2" hex head bolts, (2) 1/2" flat washers, (1) 1/2" lock washer and (1) 1/2" hex nut per hole in upright. Hand tighten all bolts at this time. Center the Grille Guard on the vehicle. Tighten all bolts at this time insuring the Grille Guard remains centered on vehicle.

7. Re-install Factory Grille and Factory Radiator Cover: Re-install Factory Grille and Factory Radiator Cover. Align Factory grille with holes in vehicle, gently push Factory Grille until it clicks closed. Take radiator cover and place it over the holes in vehicle. Replace pop rivets into vehicle.