

INSTALLATION INSTRUCTIONS AND PARTS LIST

APPLICATION: MODEL **481141** (STAINLESS STEEL) SIDE ENTRY STEP BOARDS ON:
BODY MOUNT APPLICATION

1. READ INSTRUCTIONS COMPLETELY AND CHECK TO MAKE SURE THAT ALL REQUIRED PARTS (LISTED ON SERVICE PARTS LIST) ARE ON HAND BEFORE STARTING THE INSTALLATION.
2. WITH THE STEP BOARD BRACKETS ATTACHED TO THE VEHICLE, ON THE LEFT SIDE OF THE VEHICLE PLACE THE STEP BOARD (ITEM #1) ON THE BRACKETS AND CHECK THAT THE MOUNTING HOLES LINE UP. (THE LUVERNE STICKER SHOULD BE ON THE FRONT DRIVERS SIDE)
3. USING FOUR (4) 10-24 X .75" CARRIAGE BOLTS (ITEM #3), AND FOUR (4) 10-24 FLANGE NUTS (ITEM #4) ATTACH THE STEP BOARD TO THE BRACKETS.
4. ADJUST STEP IN/OUT TO ALIGN STEP WITH THE CAB.
5. TIGHTEN THE STEP MOUNTING BOLTS.
6. REPEAT FOR RIGHT SIDE OF VEHICLE.

SERVICE PARTS LIST

ITEM	PART NO.	QTY	DESCRIPTION
1	551841	1	STEP PLATE-SES,LH,481141
2	551840	1	STEP PLATE-SES,RH,481141
3	104258	8	BOLT – CARRIAGE – SST, 10-24 X .75"
4	104261	22	NUT – FLANGE, SST, 10-24
5	104250	2	END CAP – RH FRONT/LH REAR
6	104251	2	END CAP – LH FRONT/RH REAR
7	104256	2	TRIM – SEAL, EXTRUSION, 60.50"
8	105500	2	STEP PAD, 5.50 X 20.00
9	104257	8	NUT – HEX, SINGLE THREAD
10	107958	4	SCR-PPH, #8-18 X .5", SST
11	107645	2	CLIP-U, .118-.185, BLK
12	107863	14	BOLT – CARRIAGE, 10-24 X .5", BZP



(A LUVERNE Company)

1200 E. Birch St.

Brandon, SD 57005

552665 SHEET 1 OF 2 15OCT14

INSTALLATION INSTRUCTIONS AND PARTS LIST

APPLICATION: MODEL **581141** (STAINLESS STEEL) SIDE ENTRY STEP BRACKETS ON:
1999-2013 GM 1500 REGULAR CAB PICKUPS, GAS
2001-2014 GM 2500/3500HD REGULAR CAB PICKUPS, GAS/DIESEL
BODY MOUNT APPLICATION



NO DRILL APPLICATION

1. READ INSTRUCTIONS COMPLETELY AND CHECK TO MAKE SURE THAT ALL REQUIRED PARTS (LISTED ON SERVICE PARTS LIST) ARE ON HAND BEFORE STARTING THE INSTALLATION.
2. ON THE LEFT SIDE OF THE VEHICLE PREASSEMBLE THE FRONT BRACKET (ITEMS #2, 4) AS SHOWN IN **FIG. 1** USING (3) 3/8-16 X 1.0 SCREW, 3/8" FLAT WASHERS AND 3/8" FLANGE NUT. (ITEM #8, 9, 11). TORQUE TO 19 LB. FT.

NOTE: IF YOU ARE MOUNTING THE STEPS ON A 1500 MODEL PICKUP, YOU MUST ATTACH THE SMALL 90 DEG. BRACKET (ITEM #13) TO THE FRONT BRACKETS (SEE FIG 1).

3. ASSEMBLE THE LOAD REACTION STUDS AND HARDWARE (ITEM #7 THRU #10) AS FOLLOWS.
 - 3.1. ON THE SHORT THREADED END OF THE LOAD REACTION STUD (ITEM #20), INSTALL A 3/8" SERRATED FLANGE NUT (ITEM #9) BACKWARDS TO THE BOTTOM OF THE THREAD. THEN INSTALL A 3/8" FLAT WASHER (ITEM #8) AND RUBBER "CUSHION" WASHER (ITEM #7) TIGHT UP AGAINST THE SERRATED FLANGE NUT. (THE END OF THE STUD MUST BE RECESSED IN THE RUBBER WASHER APPROX. 3/16").
 - 3.2. ON THE LONG THREADED END OF THE STUD, INSTALL A 3/8" SERRATED FLANGE NUT (ITEM #9) BACKWARDS TO NEAR TO THE BOTTOM OF THE THREADS
4. ATTACH THE LOAD REACTION STUD ASSEMBLIES TO THE MOUNTING BRACKETS AS SHOWN. INSERT THE STUD, FROM WHAT WILL BE IN THE INBOARD OR FRAME SIDE THRU THE LOWEST HOLE IN THE BENT FLANGE OF THE BRACKET THAT WILL ALLOW THE RUBBER WASHER TO SEAT FIRM AGAINST THE SIDE WALL OF THE FRAME. INSTALL A BLACK FLANGE NUT (ITEM #9) ON THE OUTBOARD END OF THE STUD (FINGER TIGHT ONLY).

NOTE:

DUE TO EXCESSIVE THREAD LOCKER IN THE BODY MOUNT BOLT AREA ON THE 2010+ GM SILVERADO/SIERRA, USE CAUTION WHEN REMOVING THE BODY MOUNT BOLTS.

5. REMOVE THE FACTORY FRONT, AND REAR BODY MOUNT BOLTS AND INSTALL THE MOUNTING BRACKETS PER THE FOLLOWING INSTRUCTIONS:
 - 5.1. INSTALL THE FRONT MOUNTING BRACKET (ITEM #4) TO THE FRONT BODY MOUNT AS SHOWN (LEAVE THESE FASTENERS FINGER TIGHT).
 - 5.2. INSTALL THE REAR MOUNTING BRACKET (ITEM #5) & WASHER (ITEM #12) TO THE REAR BODY MOUNT AS SHOWN (LEAVE THESE FASTENERS FINGER TIGHT).
6. INSTALL THE STEP BAORDS AS DESCRIBED BY THE INSRUCITONS INCLUDED WITH YOUR STEP BOARDS. (TORQUE THESE FASTENERS TO 6 LB. IN.) (**NOTE: INSURE THAT THE MOUNTING BRACKETS DO NOT TOUCH THE INSIDE WALL OF THE BODY MOUNT HOUSING AND TORQUE THE BODY MOUNT FASTENERS TO MANUFACTURES SPECS**).

LIVERNE
TRUCK EQUIPMENT

(A LIVERNE Company)

1200 E. Birch St.

Brandon, SD 57005

552687 SHEET 1 OF 3 04NOV14

7. POSITION THE LOAD REACTION BOLT ASSEMBLY SO THAT THE RUBBER CUSHION IS SNUG UP AGAINST THE SIDE OF THE FRAME. TIGHTEN THE 3/8" FLANGE NUTS ON EITHER SIDE OF THE BRACKET TO 19LB. FT.
8. REPEAT STEPS 2-7 FOR THE RIGHT SIDE OF THE VEHICLE.

ATTACHING THE STEP BOARD TO THE BRACKETS:

PLEASE REFER TO THE INSTRUCTION SHEET INCLUDED WITH YOUR STEP BOARD ASSEMBLY TO MOUNT THE STEP TO THE BRACKETS.

SERVICE PARTS LIST

ITEM	PART NO.	QTY	DESCRIPTION
1	481141	1	STEP ASSEMBLY, SES, (MOD 481141)
2	551835	1	BRACKET-MTG, FRONT, LH, 581141
3	551834	1	BRACKET-MTG, FRONT, RH, 581141
4	551831	2	BRACKET-MTG, FRONT, INBOARD, 581141
5	551815	1	BRACKET-MTG, CENTER, LH, 581141
6	551818	1	BRACKET-MTG, CENTER, RH, 581141
7	102592	4	WSHR, RUBBER, .354 ID X 1.00 OD X .75 THK
8	100062	10	WSHR, FL, 3/8", .438 ID X 1.00 OD X .083" THK
9	100181	18	NUT, SERR FLG, HEX, 3/8-16 UNC, ZP
10	104686	4	STUD, -DBL ENDED, STL, 3/8-16 X 4.00", ZP
11	100040	6	SCR-HEX HD, 3/8-16 UNC, ZP
12	108882	2	WSHR, FL, .59 ID X 1.06 OD X .19 THK, ZP
13	551571	2	BRACKET-90 DEGREE, 3 HOLE



(A LIVERNE Company)

1200 E. Birch St.

Brandon, SD 57005

SERVICE PARTS LIST

MODEL NO. - 581141

FIG. 2

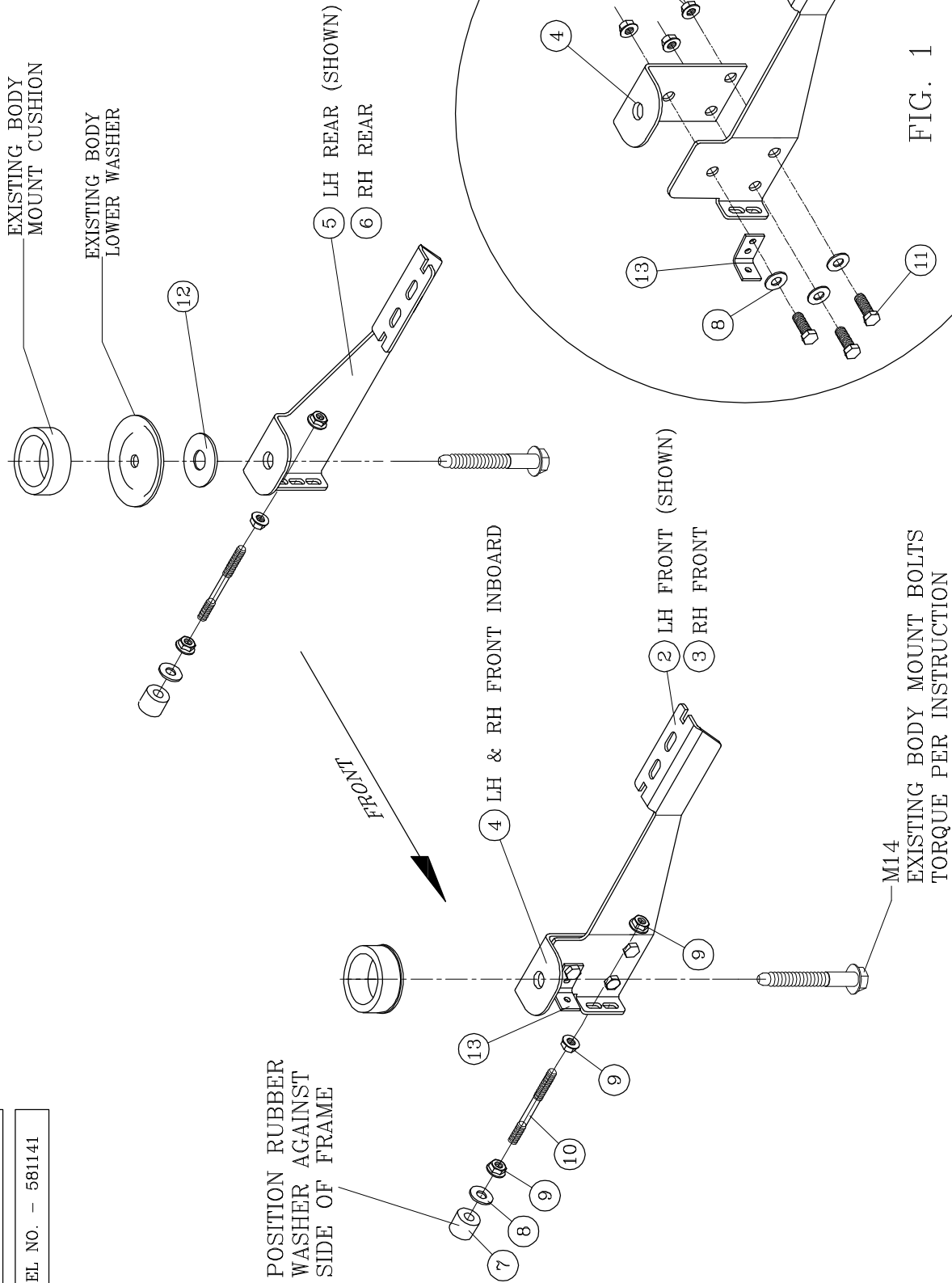

FIG. 1

POSITION RUBBER
WASHER AGAINST
SIDE OF FRAME

M14
EXISTING BODY MOUNT BOLTS
TORQUE PER INSTRUCTION

LEFT (DRIVER) SIDE SHOWN
-RIGHT (PASSENGER) SIDE OPPOSITE-



1200 E. Birch St.
Greenville, SC 27035

SERVICE PARTS LIST

MODEL NO. -481141

GM REGULAR CAB

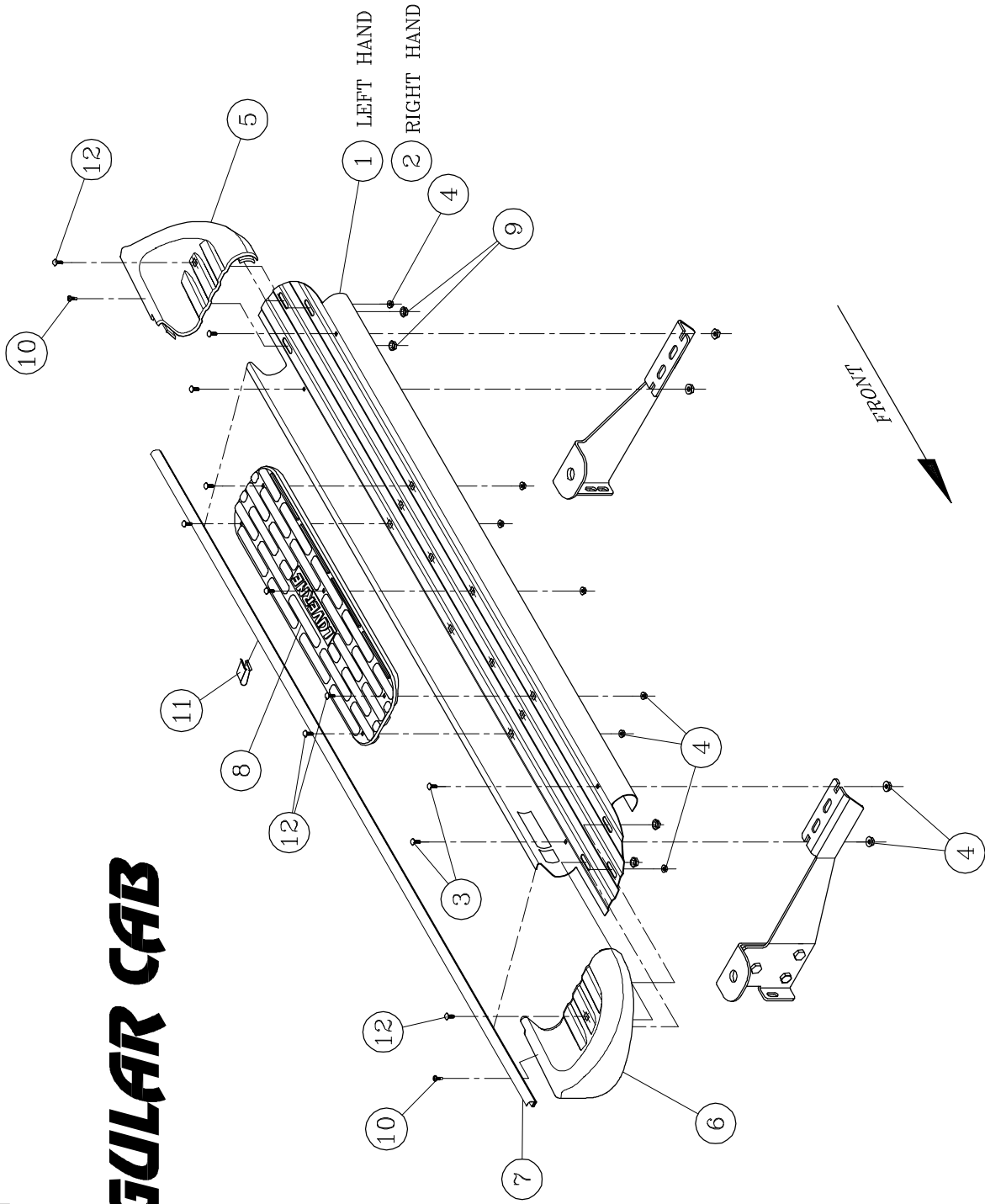

LEFT (DRIVER) SIDE SHOWN
-RIGHT (PASSENGER) SIDE OPPOSITE-

LOVERNE
A LORNER COMPANY
1200 E. Birch St.
Greenville, SD 57105