

CHEVROLET TAHOE & GMC YUKON LOGO READY REAR MUD GUARDS INSTALLATION INSTRUCTIONS

Please read instructions thoroughly before installation.

Tools Required

- 1/8" drill bit / Drill
- Center punch / Hammer
- Short Phillips screwdriver or drill attachment

Package Contents

- Driver & passenger side rear mud guard
- #10 screw (6)
- Washers (6)
- U-clip (6)
- Instruction sheet

NOTE: It may be necessary to remove the wheels depending on the tools being used for installation.

1. Remove existing fastener and u-clip from locations A and B (Figure 1).
2. Install mud guard to rear fender at location A using provided u-clip, washer and #10 screw (Figure 1). Check fit and parallel and adjust accordingly before tightening.
3. Install a u-clip, washer and #10 screw at location B. NOTE: If mud guard looks tipped inboard it may be necessary to loosen fasteners and gently pull fender toward the outboard side of vehicle and then retighten fasteners.
4. Using mud guard as a template, mark and drill 1/8" holes at location C.
5. Install #10 screw and washer at location C, thru mud guard, fender liner and into a U-clip placed on the backside of fender liner (figure 2).

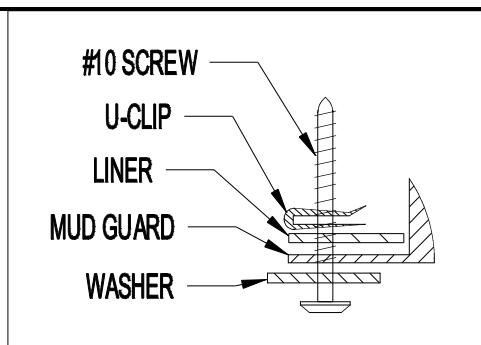

Figure 2

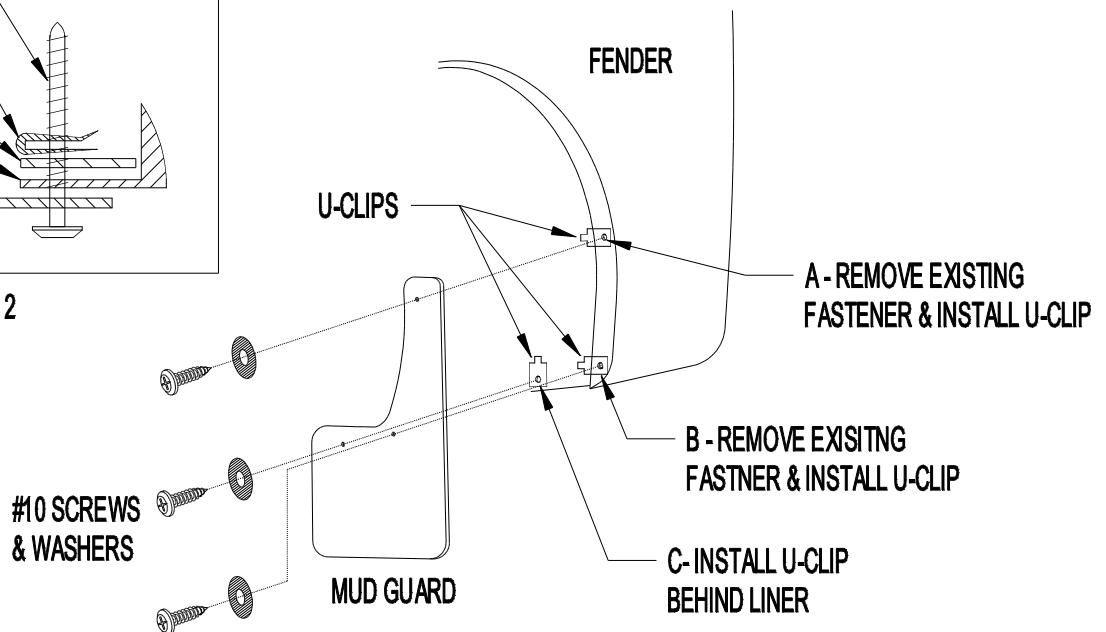

Figure 1

NEED A LOGO FOR YOUR NEW MUD GUARD? TRY AN INTERNET SEARCH FOR "EMBLEM" ON E-BAY, AMAZON OR YOUR FAVORITE AUTOMOTIVE SITE.