



FORD SUPERDUTY F250/F350 WITHOUT FENDER FLARES

PART NO. 5668

Please read instructions thoroughly before installation.

Tools Required

- 1/8" drill bit / Drill
- Short Phillips screwdriver or drill attachment

Package Contents

- Driver & passenger side front mud guard
- #10 SEM Screw (4)
- U-clip (2)
- Spring Clip (2)
- Paint Protection Film (1 set)

PAINT PROTECTION FILM INSTALLATION INSTRUCTIONS

NOTE: *The Paint Protection Film is a precut template of film used to protect the mud guard mounting surfaces of your fenders against wear. The templates (left and right side) can be removed from the backing liner by folding the liner at the center cut of the template, separating the film sides and peeling the film templates from the backing liner.*

1. Position mud guard on fender to indicate placement location of paint protection film.
2. Clean the placement area of fender with a clean cotton cloth and a petroleum distillate based cleaner such as DuPonts Prep-Sol Brand Solvent Cleaner or 3M Brand Adhesive Cleaner and dry.
3. Mix a wetting solution of 1 pint of water with 4 drops of liquid dishwashing detergent.
4. Mark correct position of film by placing mud guard against fender. **Make sure film extends beyond edge of mud guard contour a minimum of an 1/8".**
5. Remove protection film from liner and flood adhesive side of film with wetting solution (use a spray bottle or sponge).
6. Thoroughly wet film placement location of fender with wetting solution.
7. Position the adhesive side of film on fender and flood with wetting solution.
8. Check location of film with mud guard and reposition as necessary.
9. Using a sponge, squeegee any air bubbles and wrinkles from film.
10. Allow film to dry before installing mud guard.

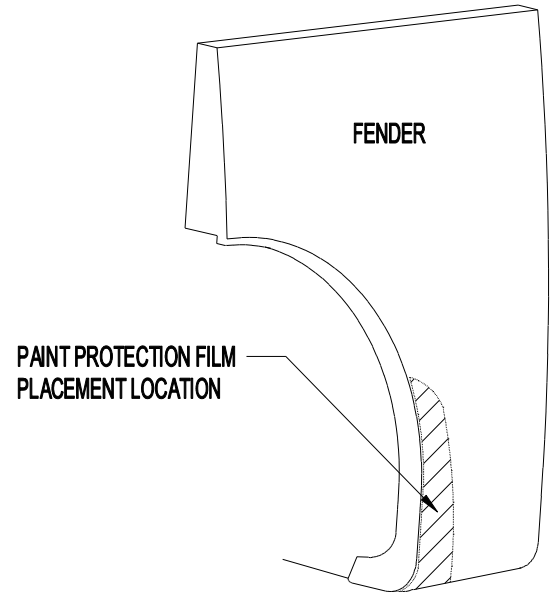

**View the Husky Liners® Lifetime Warranty at www.huskyliners.com/lifetime-warranty.
Patent and Trademark can be found at www.hl-ip.com**

MUD GUARD INSTALLATION INSTRUCTIONS

NOTE: Turn the front wheels all the way to the left or right for mud guard installation. However, it may be necessary to remove the wheels depending on the tools being used for installation.

Determine which mudguard you have by locating the part number molded in the mounting flange (5668 LH 5668 RH).

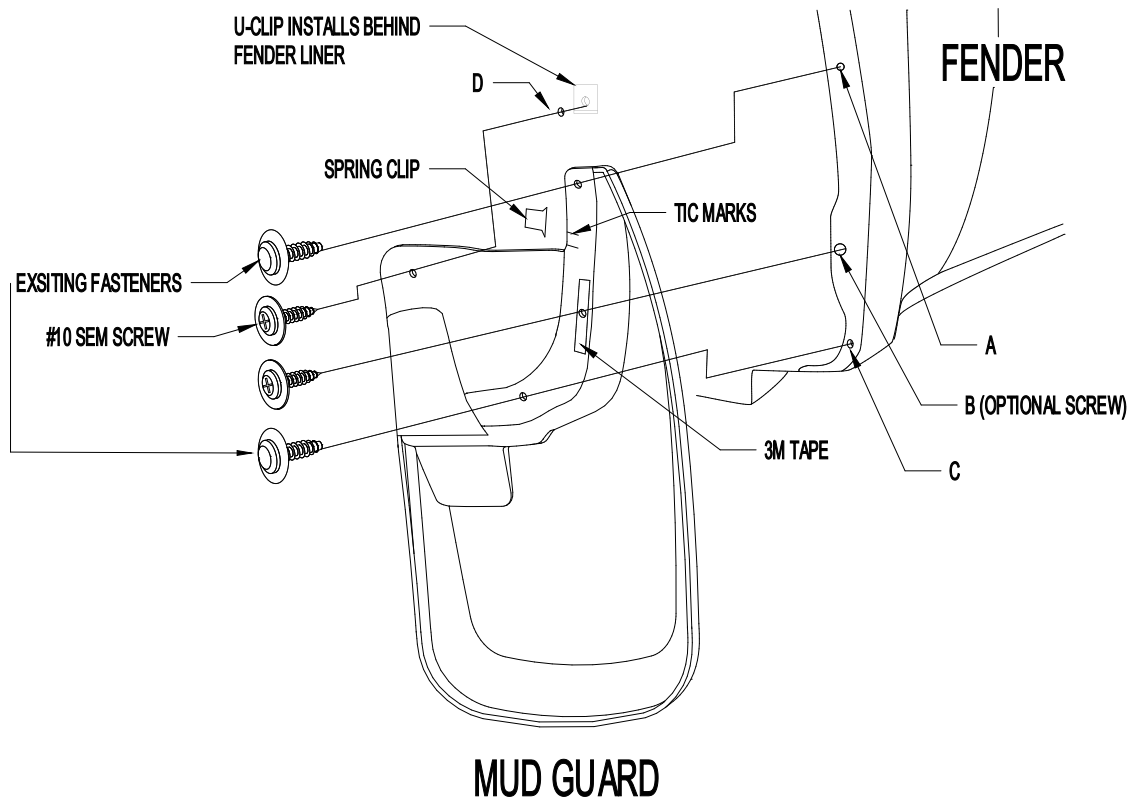

Figure 1

1. Remove existing fasteners from location A and C (Figure 1).
2. Remove the red protective coating from the tape on the mud guard.
3. Install mud guard with existing fasteners at location A and C. Check fit and make sure mud guard is parallel to ground before tightening. Apply pressure to the tape area to secure the tape (see Figure 1).
4. Install the spring clip at the tic mark location.
5. **Optional Mounting location.** Using the mudguard as a template, drill an 1/8" hole at location D. Install #10 SEM screw thru the mud guard, fender liner and into a **u-clip** behind the liner. NOTE: The u-clip is used like a nut and DOES NOT clip over fender liner (Figure 1).
6. Mark and drill 1/8" hole at locations B thru the half-filled hole in the mudguard and into the fender lip.
7. Install #10 SEM screw at location B.