

99-01 GM TRUCK / 00-01 SUBURBAN, TAHOE YUKON, YUKON-XL REAR MUD GUARD INSTALLATION INSTRUCTIONS

Please read instructions thoroughly before installation.

Tools Required:

- Short Phillips screwdriver
- 1/8" Drill bit and drill
- Center punch and marking utensil

Package Contents:

- Driver & passenger side rear mud guards
- #10 screw (qty. 6)
- U-Clip (qty. 6)
- Instruction sheet

NOTE: It may be necessary to remove the rear wheels depending on the tools being used for installation.
Clean and degrease the mud guard location area on the rear fender of the vehicle before installation.

There should be a total of three fastened locations on each mud guard. The mud guards were designed to use factory holes where possible. Fastener locations will vary depending on vehicle.

1. Install a U-Clip over any existing fender hole that will contact the mud guard (Figures 1 and 2).
2. Attach mud guard with a #10 screw through mud guard and into the U-Clip, check fit and alignment before tightening (Figure 2).
3. Where there is no factory fender hole, using mud guard as a template, center punch, drill 1/8" hole, and install a #10 screw through fender at mud guard hole locations. There should be a total of three attachment points with fasteners at location A, B or C, and D.

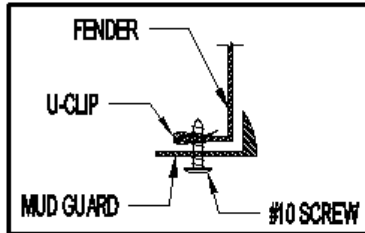

Figure 2

#10 SCREWS - FASTENER
LOCATIONS WILL VARY
DEPENDING ON VEHICLE

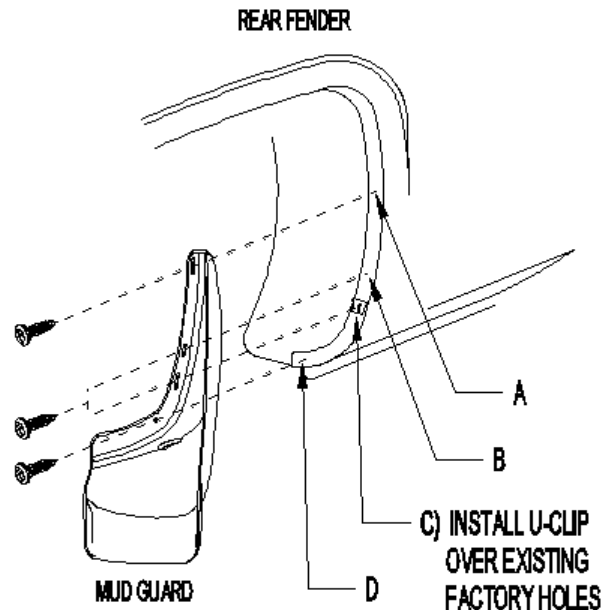

Figure 1

PAINTING INSTRUCTIONS

1. Clean mud guard with a soap and water solution to remove dirt and other contaminants.
2. Sand painting surface with 320 grit sand paper.
3. Apply a coating of flexible primer-adhesion promoter.
4. Apply a flexible paint as directed by the paint manufacturer.