

420 N. Grove, Richardson, TX 75081
 Tele: (800) 527 - 4345 Fax: (800) 442 - 5263
 Web site: www.goindustries.com
 E-mail: gosupport@goindustries.com

Big Tex Grille Guard

Installation Instructions

77642 / 77642B

Ford Super Duty ('08-'10)

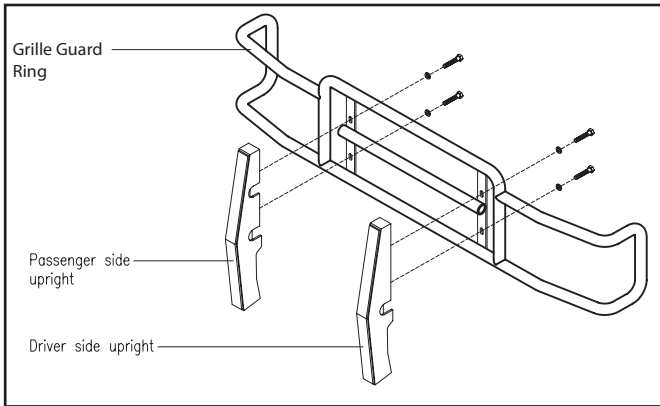

Diagram 1

Parts List:

1 - Grille Guard Ring	4 - 1/2" x 1 1/4" HH Bolts
1 - Driver Side Upright	4 - 1/2" x 2" HH Bolts
1 - Passenger Side Upright	6 - 1/2" x 1 1/2" HH Bolts
1 - Driver Rear bracket #420	10 - 1/2" Hex Nuts
1 - Passenger Rear Bracket #429	14 - 1/2" Lock Washers
2 - Brackets #642-5	18 - 1/2" Flat Washers

1. Remove the contents from the box and check for missing pieces or damage. If parts are missing or damaged, contact the original place of purchase. Please read the instructions completely before beginning installation. Two people are strongly recommended for this install.

2. Assemble the Grille Guard Ring and Uprights: See Diagram 1 and assemble the Uprights to the Grille Guard Ring. Each upright will use (2) 1/2" x 1 1/4" Hex Head Bolts and (2) 1/2" Flat Washers that will go through vertical plate on Grille Guard ring into upright. Hand tighten all bolts at this time.

3. Install Front Brackets #642-5 and Rear Brackets #420 and #429: Remove the bumper bolts on the driver side and discard. The OE bumper bolts will not be reused. The bumper bolts are located outside the tow hooks.

A) See Diagram 2: Place the Driver Rear Bracket #420 up to the back of the bumper and line up the holes with the bumper bolt holes. Locate the hole in the frame that will line up with the Driver Rear Bracket #420. Place (1) 1/2" Flat Washer on (1) 1/2" x 1 1/2" HH Bolt and insert through the frame and into the Driver Rear Bracket #420. Place (1) 1/2" Flat Washer, (1) 1/2" Lock Washer and (1) 1/2" Hex Nut on the bolt and hand tighten at this time.

B) See Diagram 3: Place the Front Bracket #640 up to bumper bolt holes and use (1) 1/2" Flat Washer on (1) 1/2" x 2" HH Bolt and insert through the Front Bracket #642-5, through the bumper holes and into the Driver Rear Bracket #420. Place (1) 1/2" Flat Washer, (1) 1/2" Lock Washer and (1) 1/2" Hex Nut on the 1/2" x 2" HH Bolt and hand tighten at this time.

C) Repeat this process for the Passenger Rear Bracket #429 and Front Bracket #642-5

4. Attach the Grille Guard to the Front Brackets #642-5: Using two people, align the Grille Guard holes to the Front Brackets #642-5. Attach the Grille Guard to brackets using (2) 1/2" x 1 1/2" HH Bolts, (2) 1/2" Flat Washers, (2) 1/2" Lock Washers and (2) 1/2" Hex Nuts per side and hand tighten at this time.

5. Center the Grille Guard on the vehicle and tighten all bolts at this time insuring the Grille Guard remains in place.

View Behind Bumper Bracket #420 Driver Side

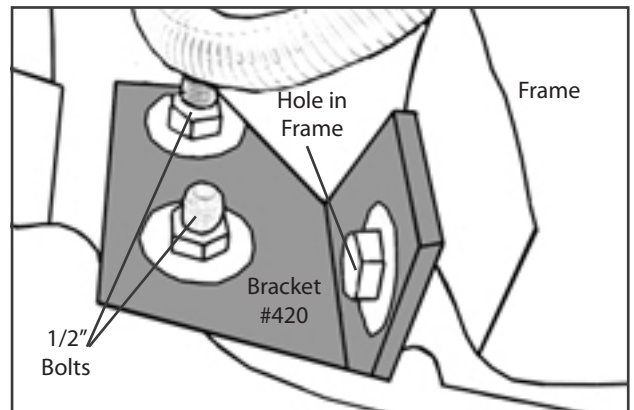

Diagram 2

View of Driver Side Bumper

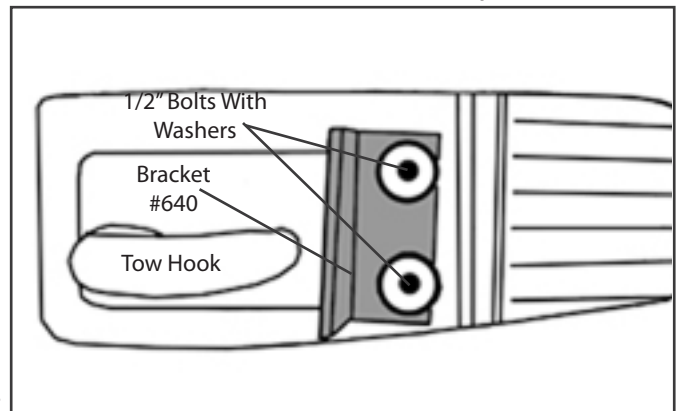

Diagram 3