



AUTOMOTIVE PRODUCTS, INC.

INSTRUCTIONS—INSTRUCCIONES—CONSIGNES

APPLICATION: 05-UP TOYOTA TACOMA, 07-UP TOYOTA TUNDRA, 03-07 CHEVY SILVERADO 1500 "CLASSIC", 07-UP CHEVY SILVERADO 1500, 03-07 CHEVY SILVERADO 2500/3500 HD, 2011-UP CHEVY SILVERADO 2500/3500 HD, 10-UP DODGE RAM 2500/3500 HD
APP PART # 46-70080, 46-70060, 46-70070, 46-70090, 46-70100
MAX WINCH TRAY FACE PLATE

ITEM	QUANTITY	DESCRIPTION	TOOLS NEEDED
1	1	WINCH TRAY FACE PLATE	3MM ALLEN WRENCH
2	4	M5 BUTTON HEAD BOLTS (STAINLESS STEEL)	8MM WRENCH
3	4	M5 FLAT WASHERS (STAINLESS STEEL)	
4	4	M5 LOCK WASHERS (STAINLESS STEEL)	
5	4	M5 HEX NUTS (STAINLESS STEEL)	

1. Remove contents from box, verify if all parts listed are present and free from damage. Carefully read and understand all instructions before attempting installation. NOTE: anti seize lubricant must be used on all stainless steel fasteners to prevent threads from galling.
2. Remove the fairlead from the front of the winch tray.
3. Take the face plate and align it to the mounting holes located in the winch tray.
4. Attach the face plate using (4) M5 button head bolts, (4) M5 flat washers, (4) M5 lock washers, and (4) M5 hex nuts. Do not fully tighten at this time.
5. Align and adjust the face plate as needed then tighten all hardware
6. Re install fairlead at this time

CARE INSTRUCTIONS

- REGULAR WAXING IS RECOMMENDED. DO NOT USE ANY TYPE OF POLISH OR WAX THAT MAY CONTAIN ABRASIVES
- STAINLESS STEEL PRODUCTS CAN BE CLEANED WITH MILD SOAP AND WATER. STAINLESS STEEL POLISH SHOULD BE USED TO POLISH SMALL SCRATCHES.
- GLOSS BLACK FINISHES SHOULD BE CLEANED WITH MILD SOAP AND WATER

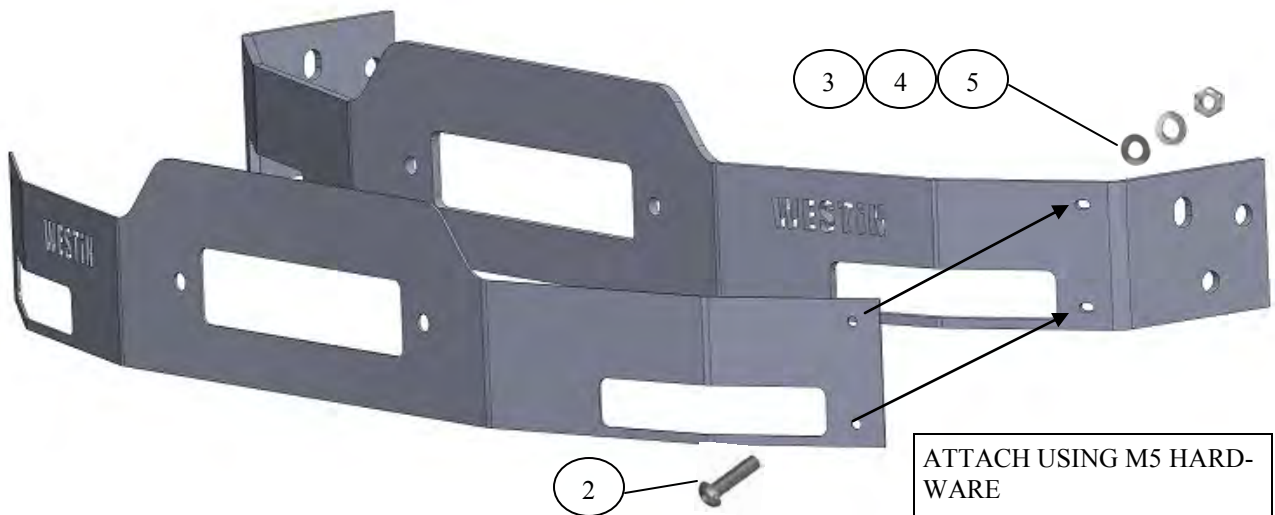

Westing Automotive Products, Inc.
5200 N. Irwindale Ave. Suite 220
Irwindale, Ca. 91706

Thank You for choosing Westin products
For Additional installation assistance please call
Customer service (800) 793-7846
www.westinautomotive.com