



INSTALLATION INSTRUCTIONS

APPLICATION: 1999-2003 SUZUKI GRAND VITARA /
GRAND VITARA XL-7

AUTOMOTIVE PRODUCTS, INC.

| | |
|--|--|
| <p>SAFARI BAR ASSEMBLY</p> <p>30-0020 30-0025</p> <p>MOUNT KIT: 30-1305</p> | |
|--|--|

| QTY | PARTS KIT CONTENTS DESCRIPTION | TOOLS REQUIRED |
|-----|--|---|
| 1 | SAFARI BAR ASSEMBLY (PURCHASED SEPARATELY) | 3/4" SOCKET 9/16" SOCKET 9/16" WRENCH 17MM SOCKET 17MM WRENCH RATCHET TORQUE WRENCH |
| 2 | TOP BRACKET | |
| 2 | BOTTOM BRACKET | |
| 2 | 1/2-13 X 2.00" HEX BOLT | |
| 2 | 1/2" FLAT WASHER | |
| 2 | 1/2" LOCK WASHER | |
| 6 | 3/8-16 X 1.25" HEX BOLT | |
| 12 | 3/8" FLAT WASHER | |
| 6 | 3/8" LOCK WASHER | |
| 6 | 3/8-16 HEX NUT | |

- STEP 1. Remove the contents from the box and check for any damage. Verify all parts against the parts list.
- STEP 2. Read and understand instructions completely before beginning installation.
- STEP 3. Determine passenger and driver top and bottom brackets. Assemble brackets as shown using 3/8" fasteners. Leave loose. SEE FIGURE 1.
- STEP 4. Remove outside/front bolt from front cross member. Loosen rear bolt to sufficiently clear bracket assembly. **DO NOT REMOVE REAR BOLT COMPLETELY.**
CAUTION: Weight of vehicle must be on wheels during installation.
- STEP 5. Slide appropriate Safari Bar bracket onto rear bolt. Reinstall front bolt and tighten both hand tight. Repeat for opposite side of vehicle. SEE FIGURE 1.
- STEP 6. Attach Safari Bar to bracket assembly using 1/2" fasteners. Hand tighten.
- STEP 7. Center and level the Safari Bar. Torque 1/2" fasteners to 65 FT.LBS, 17mm fasteners to 68 FT.LBS. and 3/8" fasteners to 35 FT.LBS.

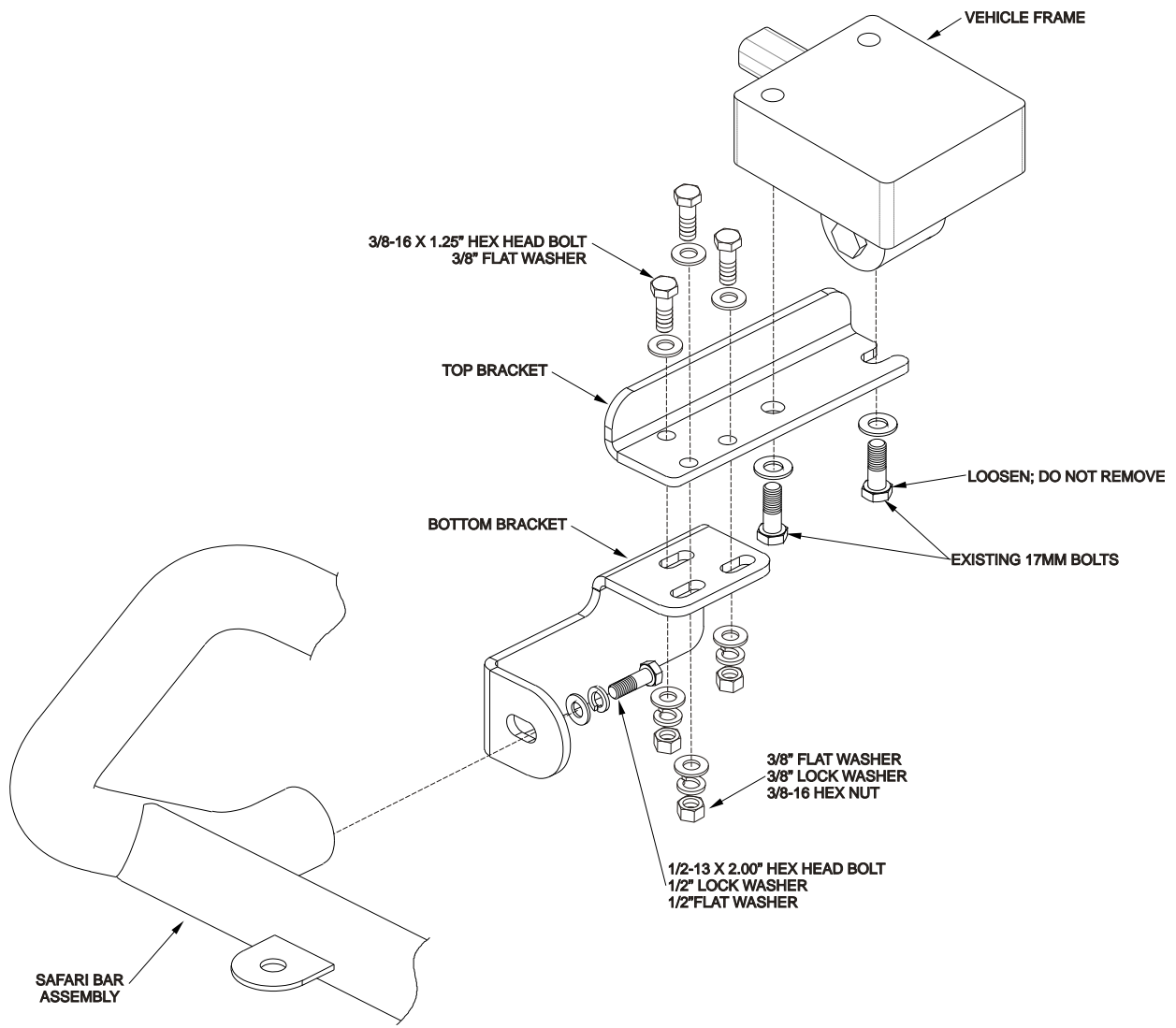

FIGURE 1
INSTALLATION VIEW OF PASSENGER SIDE, DRIER SIDE OPPOSITE

Finish protection - Westin products have a high quality finish that must be cared for like any other exposed finish on the vehicle. Protect the finish with a non-abrasive automotive wax (pure carnauba, for example) on a regular basis. The use of cleaner wax or any compound which contains an abrasive is detrimental, as the compounds scratch the finish and open it to corrosion.



Westin Automotive Products, Inc.
 5200 N. Irwindale Ave. Suite 220
 Irwindale, Ca. 91706

Thank You for choosing Westin products
 For additional installation assistance please call
 Customer service (800) 793-7846 or (507) 375-3559