



INSTALLATION INSTRUCTIONS

SURE-GRIP RUNNING BOARD MOUNT KIT

AUTOMOTIVE PRODUCTS,

APPLICATION:

2009-2015 Dodge Ram 1500 Quad/Crew Cab
 2010-2015 Dodge Ram 2500/3500 Crew Cab

PART NUMBER:

27-1905

ITEM	QUANTITY	DESCRIPTION	TOOLS NEEDED
1,2	2	RUNNING BOARD, DRIVER AND PASSENGER	13MM SOCKET
3	1	FRONT DRIVER MOUNTING BRACKET	17MM SOCKET
4	2	DRIVER CENTER / PASSENGER REAR MOUNTING BRACKET	ALLEN KEY
5	3	PASSENGER FRONT/CENTER / DRIVER REAR MOUNTING BRACKET	3/8" WRENCH
6	5	M10 BOLT / M8 NUT PLATE (YELLOW ZINC)	DRILL
7	12	M8 HEX HEAD BOLT (YELLOW ZINC)	1/4" DRILL BIT
8	12	M8 FLAT WASHER (YELLOW ZINC)	RATCHET
9	12	M8 SPLIT LOCK WASHER (YELLOW ZINC)	TORQUE WRENCH
10	7	M8 RIV-CERTS (YELLOW ZINC)	
11	5	M10 FLAT WASHER (YELLOW ZINC)	
12	5	M10 HEX NUT (YELLOW ZINC)	
13	5	M10 LOCK WASHER (YELLOW ZINC)	
14	12	5/16" SQUARE HEAD BOLT (YELLOW ZINC)	
15	12	5/16" SAE FLAT WASHER (YELLOW ZINC)	
16	12	5/16" NYLON LOCK NUT (YELLOW ZINC)	
17	5	M10 PLASTIC RETAINER	
18	2	M6 BUTTON HEAD BOLTS (STAINLESS STEEL)	
19	2	M6 FLAT WASHERS (STAINLESS STEEL)	
20	2	M6 SERRATED FLANGE NUT (STAINLESS STEEL)	

ANTI-SEIZE LUBRICANT MUST BE USED ON ALL STAINLESS STEEL FASTENERS TO PREVENT THREAD DAMAGE AND GALLING

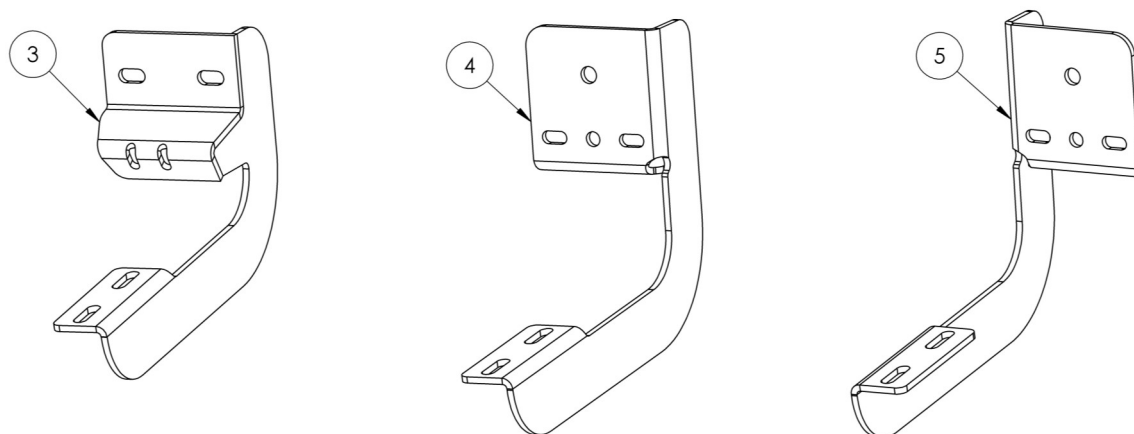

Westin Automotive Products, Inc.
 320 W. Covina Blvd
 San Dimas, Ca. 91773

Thank you for choosing Westin products
 for additional installation assistance please call
 Customer Service (800) 793-7846

PROCEDURE

1. Remove contents from box, verify if all parts listed are present and free from damage.
Carefully read and understand all instructions before attempting installation.
Failure to identify damage before installation could lead to a rejection of any claim.
2. Check either side of the vehicles rocker panel, locate the factory holes in the rocker panel by removing the tape. Check and verify what type of rocker panel is present. **See Fig. 1, 2, 3, & 4.** *Note:* If any of the locations on the factory holes in the rocker panel have factory M8 riv-certs or threaded M8 holes, do not use provided M8 riv-certs (item 10) in that location. **Refer to Fig. 1, 2 & 4.**
3. **Starting from the driver side:** If the threaded holes are not present use (2) M8 riv-certs (item 10) and insert them into the hex holes. *Note:* See Figure 6 for example on how to tighten M8 riv-certs, it will require to use an M10 bolt with M8 nut plate (item 6) along with a bracket to perform this task. Use Figure 8 on how to position (item 6). This procedure will permanently install M8 riv-cert. Remove (item 6) after the riv-certs are tightened.
4. Proceed to install the Drivers side front bracket (item 3) onto the rocker panel by using (2) M8 hex bolts (item 7), (2) M8 lock washers (item 9), (2) flat washers (item 8). For the pinch weld, attach bracket (item 3) by using (2) M6 Button head bolts (item 18), (2) M6 flat washers (item 19) & (2) M6 serrated flange nuts (item 20). *Note:* Drilling of two 1/4" holes might be necessary on pinch weld if factory holes are not present. Before drilling place masking tape on drill surface to prevent paint chipping. **See Fig. 9 & 10.**
5. On the middle mounting location of drivers side attach (1) M8 riv-cert to rocker panel if not already present. Then proceed to install (1) M10 bolt/M8 nut plate (Item 6) into the rocker panel and thread (1) M10 plastic retainer (Item 17) to the M10 bolt to prevent it from falling into the rocker panel. **See Fig. 5.**

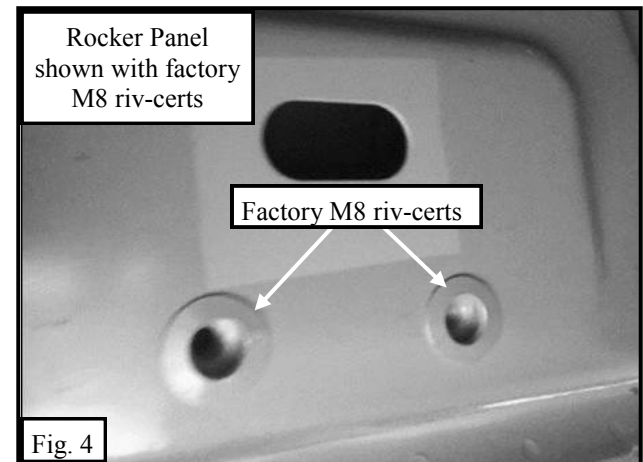
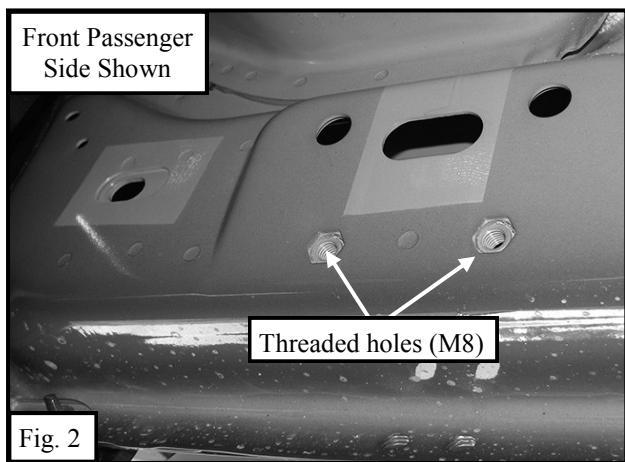
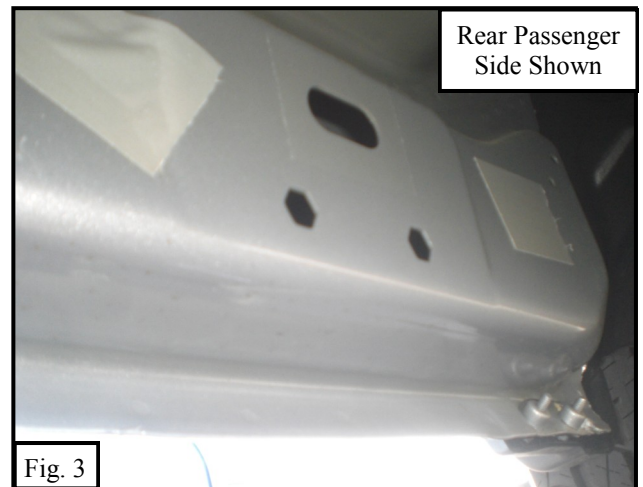
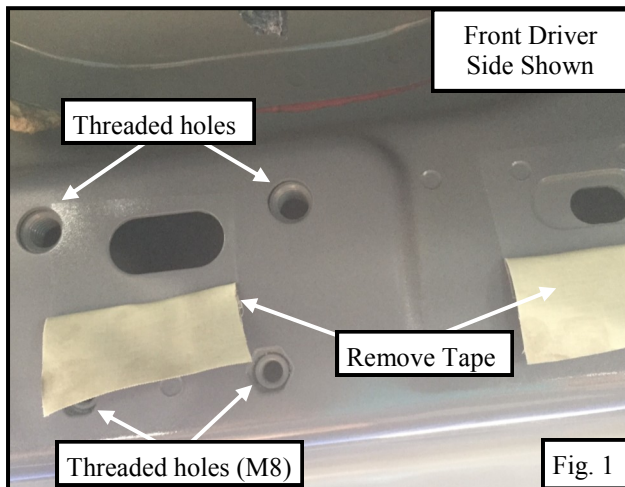

Westin Automotive Products, Inc.
320 W. Covina Blvd
San Dimas, Ca. 91773

Thank you for choosing Westin products
for additional installation assistance please call
Customer Service (800) 793-7846

6. Attach center mounting bracket (item 4) to the rocker panel by first tightening the M8 riv-cert into place. **See Fig. 6.** Then continue by attaching center bracket (item 4) and aligning (item 6) (as shown on figure 5), using (2)M8 hex bolts (item 7), (2) M8 lock washers (item 9), (2) M8 flat washers (item 8), (1) M10 flat washer (item 11), (1) M10 lock washer (item 13) & (1) M10 hex nut (item 12). Leave everything loose at this time. **See Fig. 11.**
7. For rear mounting bracket installation of the drivers side use (item 5) bracket and the same installation procedure as step 6.
8. **Starting from the Passenger side:** Insert (1) M10 bolt/M8 nut plate (Item 6) into the rocker panel and thread (1) M10 plastic retainer (Item 17) to the M10 bolt to prevent it from falling into the rocker panel. **See Fig. 5.**
9. If the front of the rocker panel has pre-installed M8 riv-certs, the M10/M8 plate (item 6) will need to be positioned as shown in Figure 8.
10. If the front rocker panel does not have pre-installed M8 riv-certs then (item 6) will be used as shown on Figure 5 & 11.
11. Attach brackets (item 5) to passenger front and center locations & (item 4) to passenger rear using the same procedure as step 6.
12. Take the 5/16" square head bolts and insert them into the channel underneath the running board (3 per channel) and align with brackets. Attach running board (items 1 & 2) respectively to either side using (6) 5/16" square head bolts (item 14), (6) 5/16" SAE flat washers (item 15) & (6) 5/16" nylon lock nut (item 16). Do not fully tighten at this time.
13. Align and adjust the step bars as needed then fully tighten all hardware at this time. Torque all M10 fasteners to 30 ft-lbs, M6 fasteners to 10-15 ft-lbs, 5/16 to 10-15 ft-lbs and M8 to 20 ft-lbs.

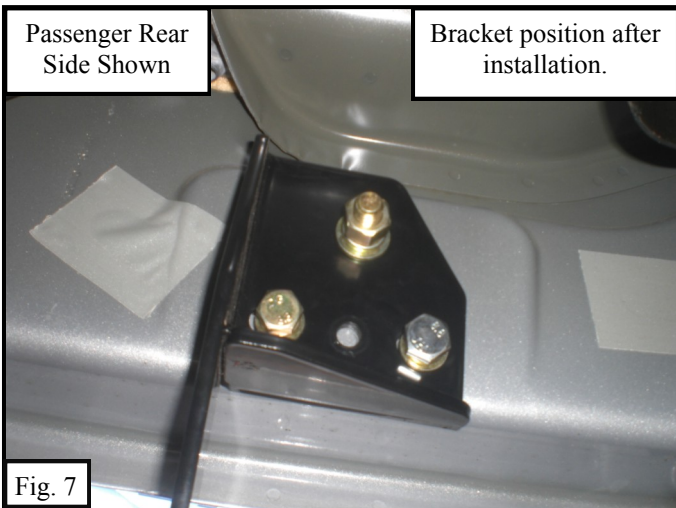
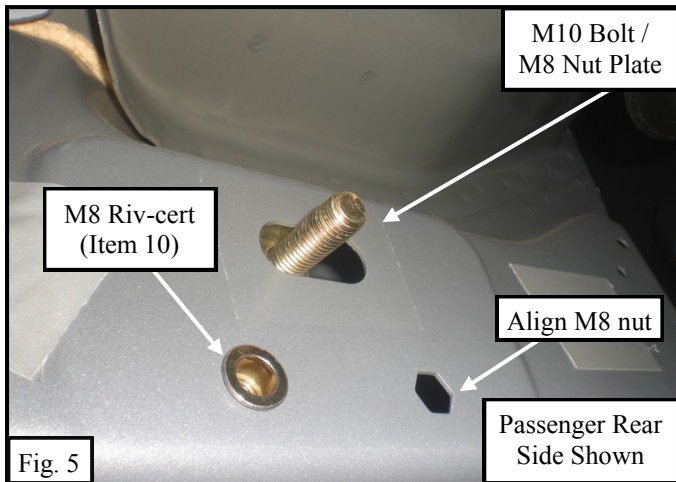

Note: Fig. 6 & 7 is shown for riv-cert installation purposes only, it does not represent the mounting bracket included in this kit.

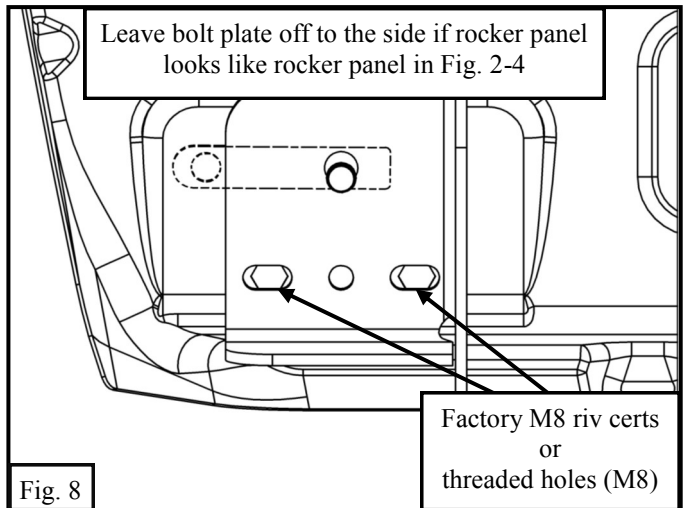
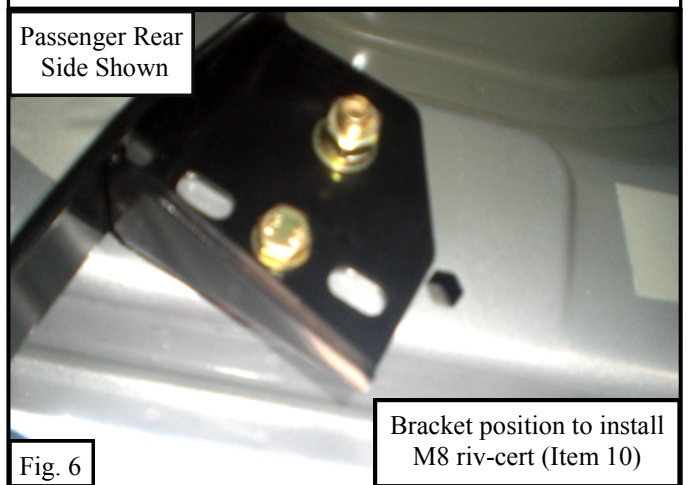

Westin Automotive Products, Inc.
320 W. Covina Blvd
San Dimas, Ca. 91773

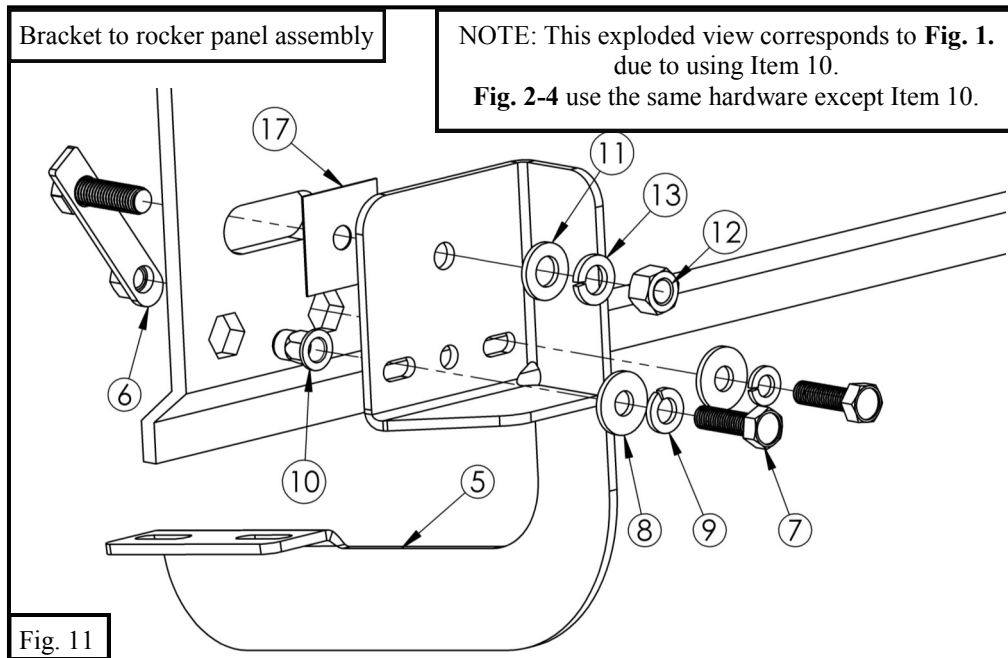
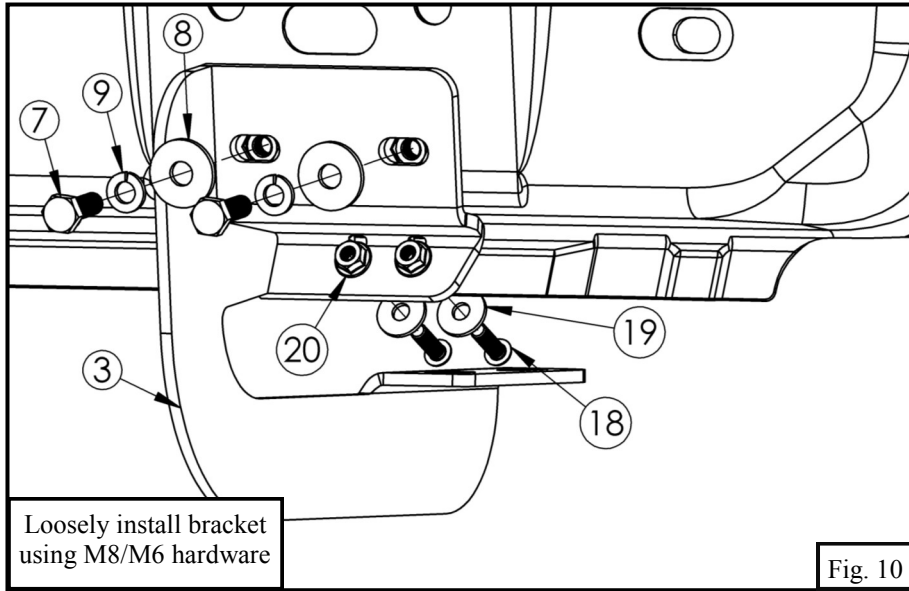
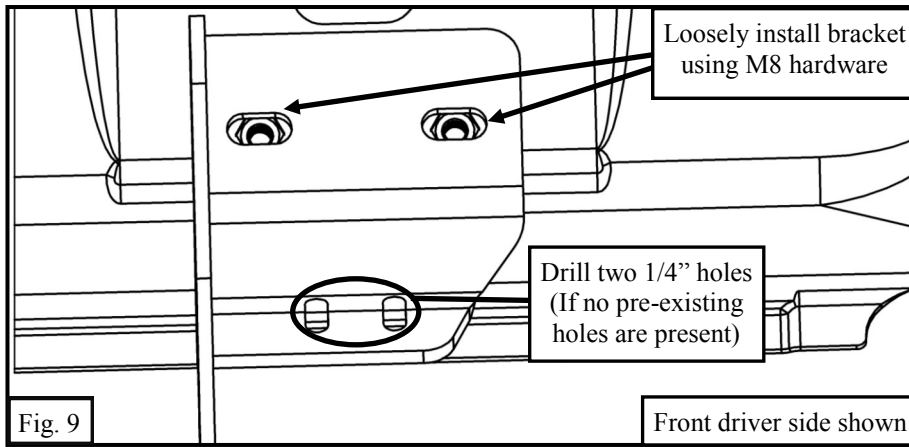

INSTALLATION COMPLETE



CARE INSTRUCTIONS

- REGULAR WAXING IS RECOMMENDED. DO NOT USE ANY TYPE OF POLISH OR WAX THAT MAY CONTAIN ABRASIVES.
- STAINLESS STEEL PRODUCTS CAN BE CLEANED WITH MILD SOAP AND WATER. STAINLESS STEEL POLISH SHOULD BE USED TO POLISH SMALL SCRATCHES.
- GLOSS BLACK FINISHES SHOULD BE CLEANED WITH MILD SOAP AND WATER.



Westin Automotive Products, Inc.
320 W. Covina Blvd
San Dimas, Ca. 91773

Thank you for choosing Westin products
for additional installation assistance please call
Customer Service (800) 793-7846

www.westinautomotive.com