



AUTOMOTIVE PRODUCTS,

# INSTALLATION INSTRUCTIONS

## R5 STEP BOARD

### APPLICATION:

2015-2016 Chevrolet Colorado / GMC Canyon Ext. Cab  
2016 Chevrolet Colorado / GMC Canyon Crew Cab

### PART NUMBER:

28-51000, 28-51005, 28-51010, 28-51015

ITEM	QUANTITY	DESCRIPTION	TOOLS NEEDED
1,2	2	STEP BOARDS, DRIVER (1) AND PASSENGER (2)	10MM SOCKET
3	3	MOUNT BRACKET A	13MM SOCKET
4	3	MOUNT BRACKET B	RATCHET
5	6	ADAPTER PLATE (ONLY FOR 28-51000 & 28-51010)	TORQUE WRENCH
6	6	PLASTIC BRACKET COVER	
7	12	M8 EXTRUDED U-NUT (YELLOW ZINC)	
8	12	M6 HEX HEAD CAP SCREW (YELLOW ZINC)	
9	24	M6 FLAT WASHER (YELLOW ZINC)	
10	12	M6 NYLOCK NUT (YELLOW ZINC)	
11	12	M8 HEX HEAD CAP SCREW (BLACK ZINC) SEMS HARDWARE	
12	12	M8 SPLIT LOCK WASHER (BLACK ZINC) SEMS HARDWARE	
13	12	M8 FLAT WASHER (BLACK ZINC) SEMS HARDWARE	
14	12	M8 HEX NUT (BLACK ZINC)	
15	12	M8 SPLIT LOCK WASHER (BLACK ZINC)	
16	12	M8 FLAT WASHER (BLACK ZINC)	
17	12	M8 SQUARE HEAD BOLT (ONLY FOR 28-51005 & 28-51015)	

**ANTI-SEIZE LUBRICANT MUST BE USED ON ALL STAINLESS STEEL FASTENERS TO PREVENT THREAD DAMAGE AND GALLING**

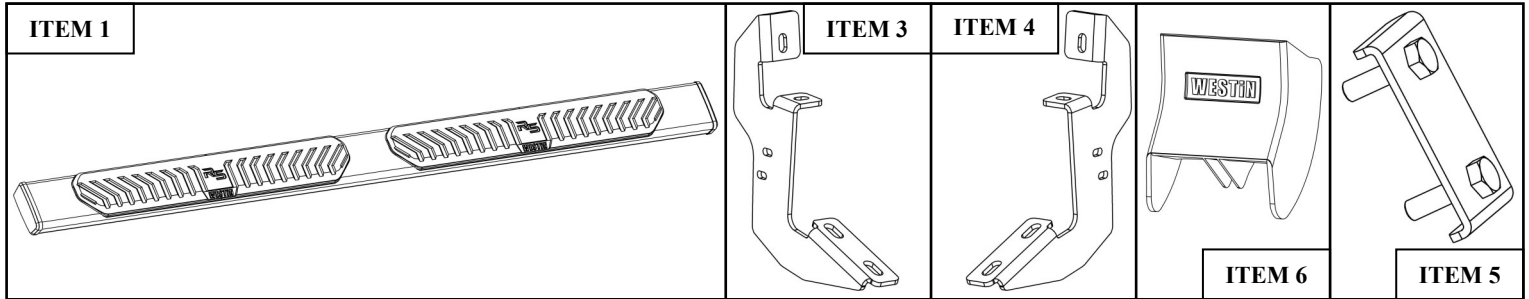

### PROCEDURE

- Remove contents from box, verify if all parts listed are present and free from damage. Carefully read and understand all instructions before attempting installation.  
**Failure to identify damage before installation could lead to a rejection of any claim.**
- Remove the rubber plugs located on the rocker panel at each bracket mounting location. See **Figure 1**.
- Locate (1) mounting bracket A and loosely secure it to the driver side rocker panel mount locations using the provided hardware: (2) M8 hex head bolt, (2) M8 flat washer, (2) M8 lock washer, and (2) M8 u-nut clip. See **Figure 2**.
- Repeat **Step 3** for every other bracket mounting location. Use mount bracket B on passenger side.



Westin Automotive Products, Inc.  
320 W. Covina Blvd  
San Dimas, Ca. 91773

Thank you for choosing Westin products  
for additional installation assistance please call  
Customer Service (800) 793-7846

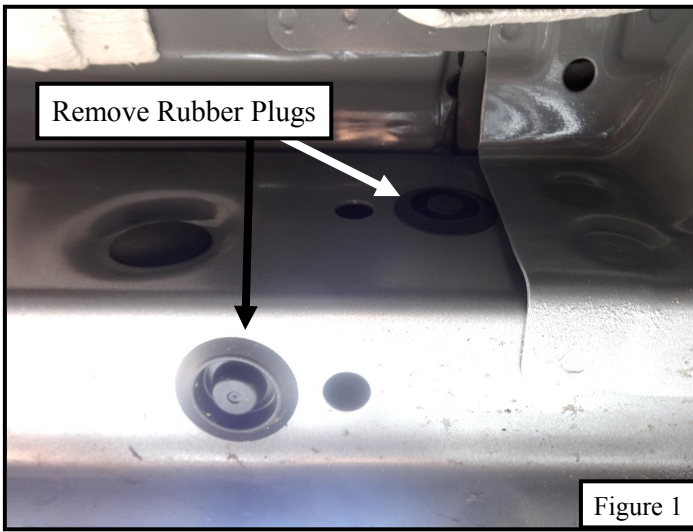

Figure 1

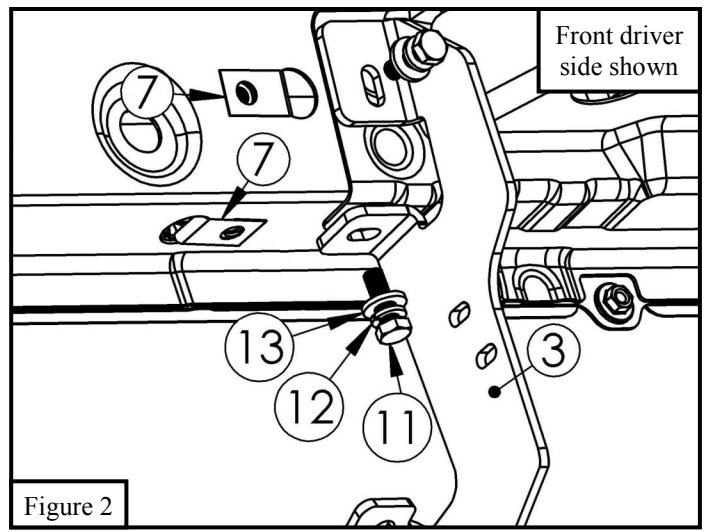

Figure 2

5. Locate (1) plastic bracket cover (Item 6) and loosely secure it to the (6) brackets using the provided hardware: (2) M6 hex head bolts, (4) M6 flat washers, and (2) M6 nylon lock nuts. Repeat for every bracket. See **Figure 3**.
6. **For Part Numbers 28-51005 and 28-51015:** Locate (1) driver side step board (Item 1) and (6) M8 square head bolts (Item 17). Slide the M8 square head bolts through the slots underneath the step board and align with the previously installed mount brackets. Repeat for passenger side. See **Figure 4**.
7. **For Part Numbers 28-51000 and 28-51010:** Locate (1) driver side step board (Item 1) and (3) adapter plates (Item 5). Insert the adapter plates onto the step board and align with the previously installed mount brackets. Repeat for passenger side. See **Figure 5**.

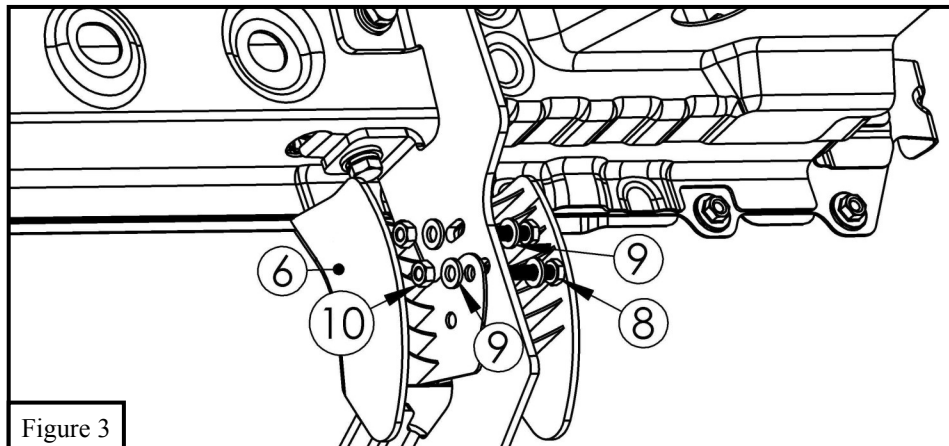
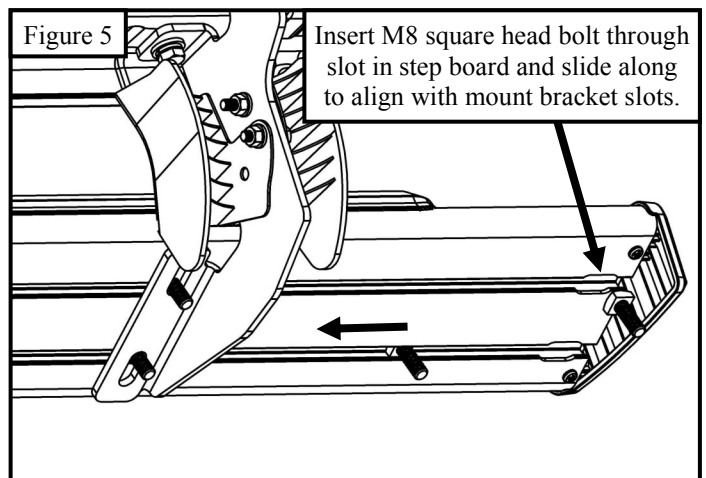
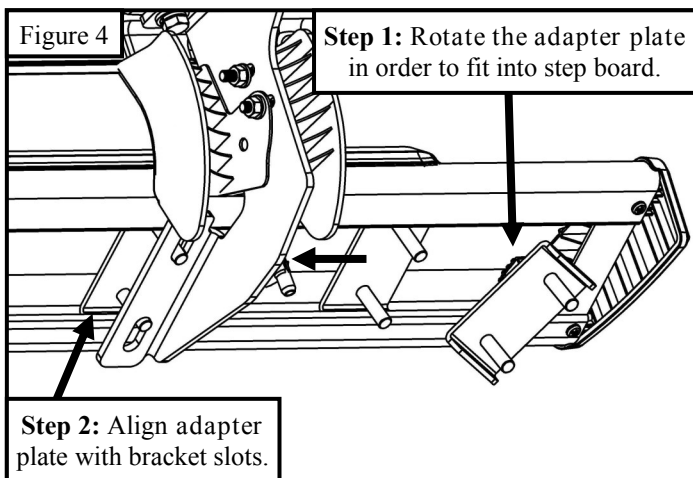

Figure 3



Westin Automotive Products, Inc.  
320 W. Covina Blvd  
San Dimas, Ca. 91773

Thank you for choosing Westin products  
for additional installation assistance please call  
Customer Service (800) 793-7846

8. Loosely secure the step board onto each mount bracket using (2) M8 hex nuts, (2) M8 split lock washers, and (2) M8 flat washers (Items 11 - 13). See **Figure 6**.
9. Adjust and align as necessary the mount brackets, step boards, and bracket covers and then tighten M8 hardware to 15-17 ft-lbs and M6 to 5-7 ft-lbs.

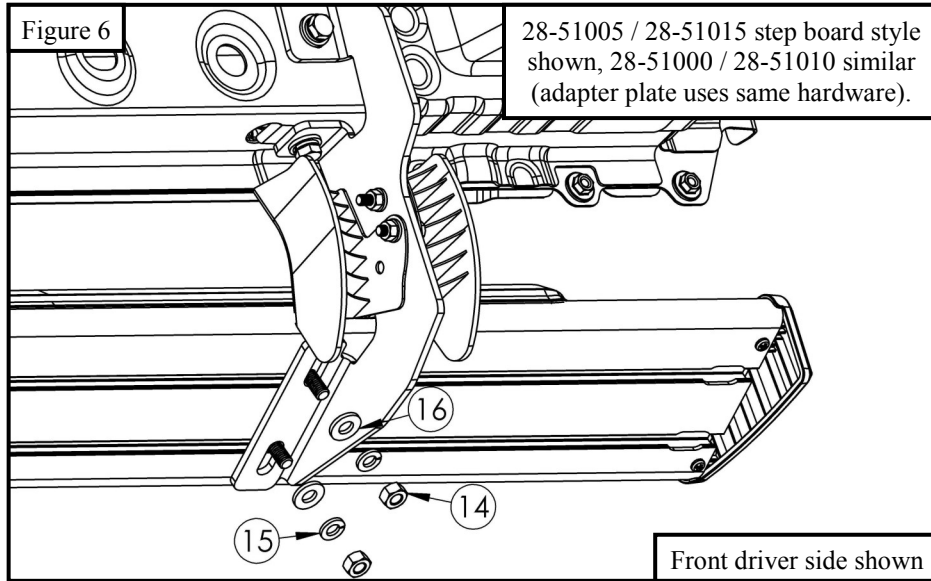

#### CARE INSTRUCTIONS

- REGULAR WAXING IS RECOMMENDED. DO NOT USE ANY TYPE OF POLISH OR WAX THAT MAY CONTAIN ABRASIVES.
- STAINLESS STEEL PRODUCTS CAN BE CLEANED WITH MILD SOAP AND WATER. STAINLESS STEEL POLISH SHOULD BE USED TO POLISH SMALL SCRATCHES.
- GLOSS BLACK FINISHES SHOULD BE CLEANED WITH MILD SOAP AND WATER.



Westin Automotive Products, Inc.  
320 W. Covina Blvd  
San Dimas, Ca. 91773

Thank you for choosing Westin products  
for additional installation assistance please call  
Customer Service (800) 793-7846

[www.westinautomotive.com](http://www.westinautomotive.com)

# Westin

SIGNATURE OF QUALITY

AUTOMOTIVE PRODUCTS, INC.



## WARNING



Failure to follow these instructions could lead to death, personal injury, and / or property damage.

### FASTENERS:

All Westin supplied fasteners must be utilized and installed in accordance with the installation instructions and apply torque to the specifications as defined. **DOUBLE CHECK ALL FASTENERS BEFORE INITIAL USE, AND PERIODICALLY IN THE FUTURE TO ENSURE PROPER FUNCTION AND SAFETY.**

### DRILLING:

Most Westin products do not require drilling for installation. If drilling is defined as required, use caution when drilling a vehicle. **FAILURE TO REVIEW AN AREA TO BE DRILLED MAY RESULT IN PERSONAL INJURY AND/OR INJURY TO OTHERS AS WELL AS VEHICLE DAMAGE.**

### EYE PROTECTION:

**ALWAYS WEAR SAFETY GLASSES OR GOGGLES DURING THE INSTALLATION PROCESS TO AVOID PERSONAL INJURY.**

### MAXIMUM TOWING/CARRYING CAPACITY:

The Westin Receiver Hitches will have a visible tow rating label affixed directly on the product. User should never exceed the vehicle manufacturers maximum tow and weight rating regardless of the capacity of the hitch. **FAILURE TO FOLLOW THESE GUIDELINES WILL VOID THE WESTIN WARRANTY AND MAY RESULT IN PERSONAL INJURY AND/OR INJURY TO OTHERS AS WELL AS VEHICLE DAMAGE.**

**Westin**  
SIGNATURE OF QUALITY

Westin Automotive Products, Inc.  
320 W. Covina Blvd  
San Dimas, Ca. 91773