



INSTALLATION INSTRUCTIONS

PRO-E ELECTRIC RUNNING BOARDS

APPLICATION:
Ford F-150 Super Cab 2015-2023;
F-250/350 Super Cab 2017-2023

PART NUMBER:
29-23935



Estimated Time to Complete Product Installation: 3 - 4 Hours

CONTENTS

- Component List Page 02
- Electrical Component Installation Procedure Page 05
- Mechanical Component Installation Procedure Page 11
- Product Warranty and Warnings Page 17

COMPONENT LIST

ITEM	QUANTITY	DESCRIPTION	TOOLS NEEDED
1	2	RUNNING BOARD ASSEMBLY	5MM ALLEN WRENCH
2	1	DRIVER SIDE FRONT MOTOR LINKAGE	
3	1	PASSENGER SIDE FRONT MOTOR LINKAGE	13MM SOCKET
4	1	DRIVER SIDE REAR MOTOR LINKAGE	13MM WRENCH
5	1	PASSENGER SIDE REAR MOTOR LINKAGE	WIRE STRIPPER
6	1	CONTROL MODULE ASSEMBLY	ELECTRICAL TAPE
7	2	FUSE	RATCHET
8	1	POWER BOARD MANUAL SWITCH	TORQUE WRENCH
9	2	MAGNETIC INDUCTION MODULE	
10	4	DOOR MAGNET	
11	4	LED LIGHTS	
12	1	WIRING HARNESS	
13	8	M6 HEX SOCKET CAP SCREW	
14	14	M8 HEX NUT	
15	14	M8 SPLIT LOCK WASHER	
16	14	M8 FLAT WASHER	
17	25	ZIP TIES	

Remove the components from the box, verify if all parts listed are present and free from damage.

Carefully read and understand all instructions before attempting installation.

Note that failure to identify damage before installation could lead to a rejection of any claim.

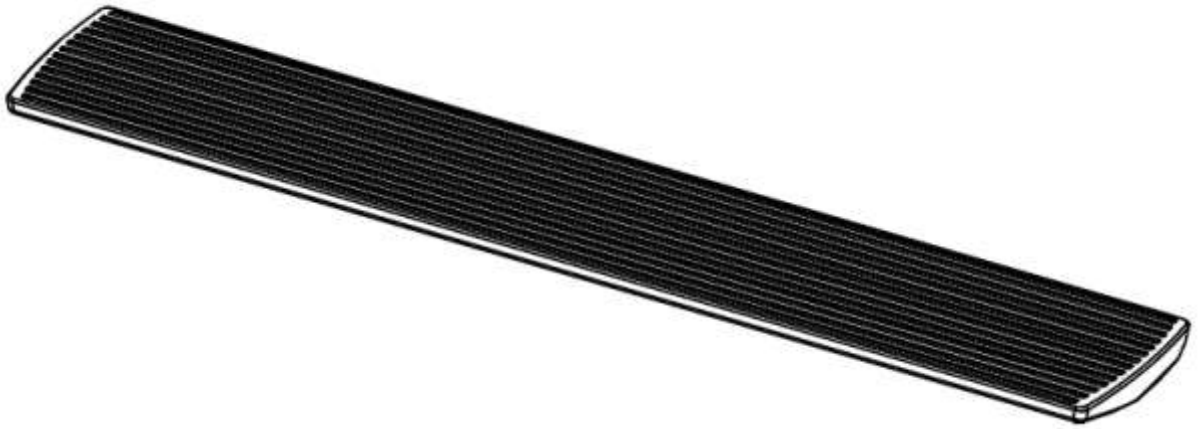

ITEM 1

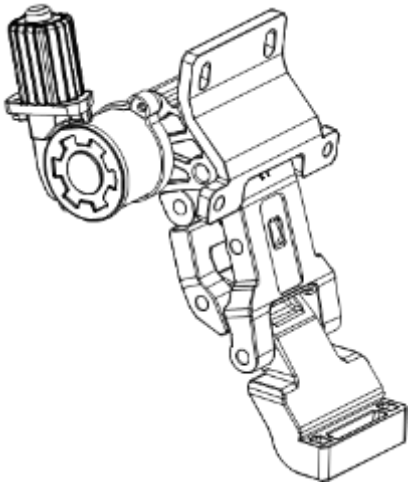

ITEM 2

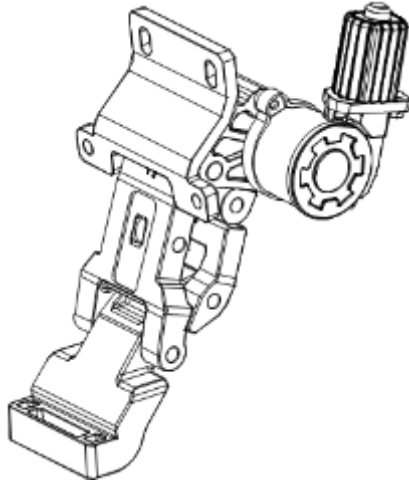

ITEM 3

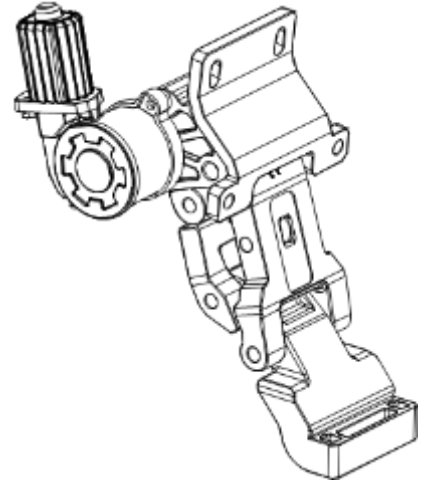

ITEM 4

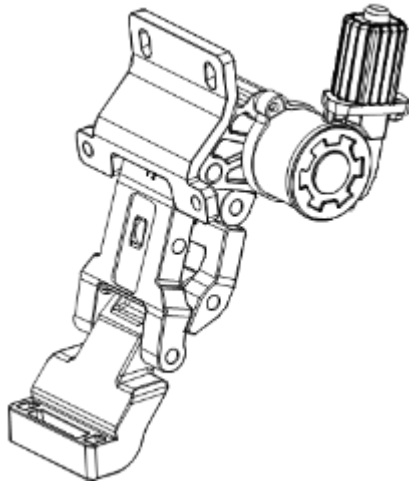

ITEM 5

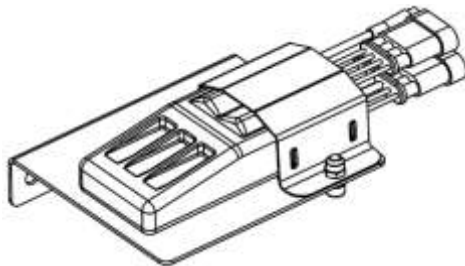

ITEM 6

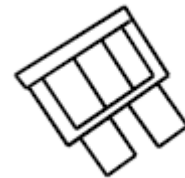

ITEM 7

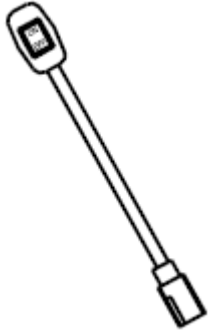

ITEM 8

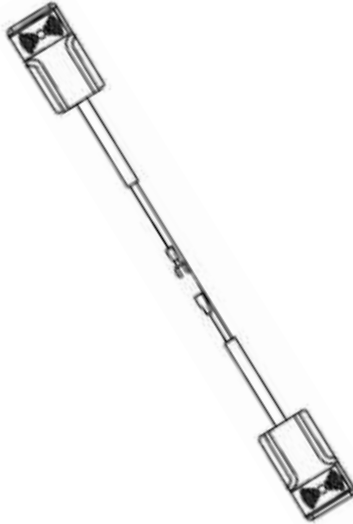

ITEM 9



ITEM 10

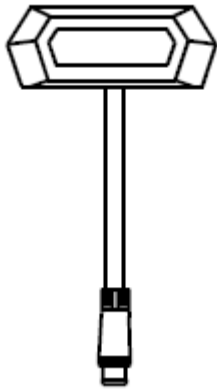

ITEM 11



ITEM 12



ITEM 17

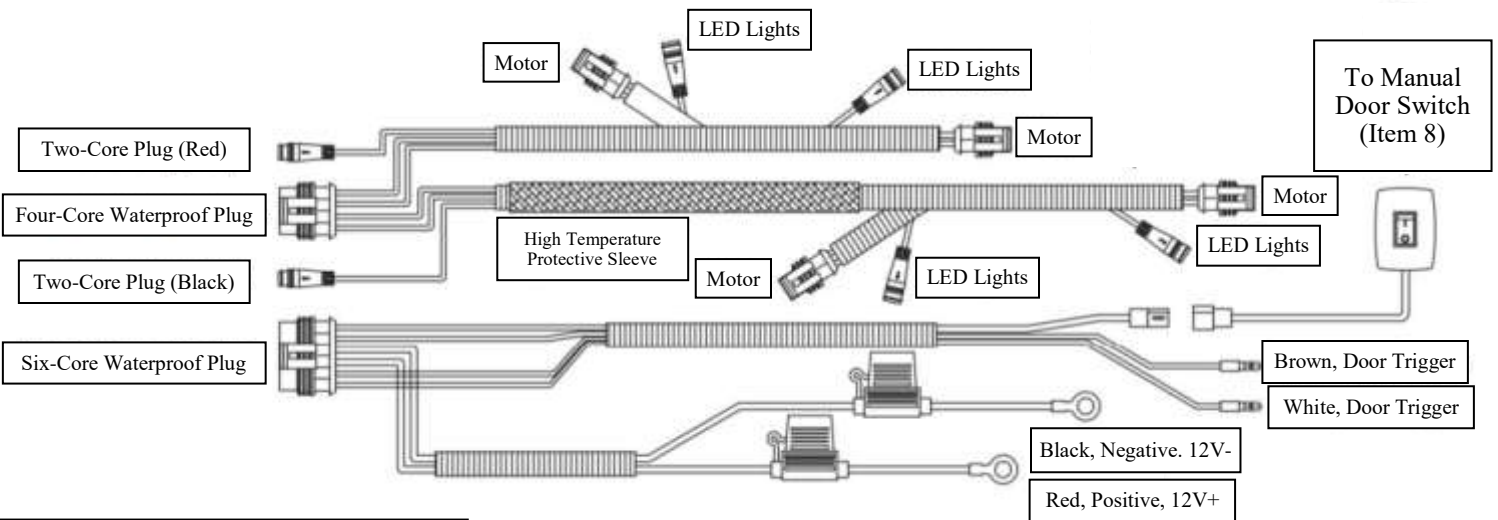

ITEM 12: Wiring Harness Leads

ELECTRICAL COMPONENT INSTALLATION PROCEDURE

1. Begin by disconnecting the battery from the vehicle. Start with the negative battery terminal, then the positive battery terminal.
2. On both the driver and passenger side of the vehicle, remove the front and rear door sill trim panels, and the B-Pillar trim panel by carefully pulling on the panels enough to release them from the plastic retaining clips. See **Figures 1 through 3** for reference.
3. With the panels removed, pull the front passenger side carpet back to reveal the rubber grommet in the location shown. Drill or cut a 7/16-1/2" opening into the grommet, and feed the door trigger signal white and brown wires and the two black manual switch wires into the cab of the vehicle. See **Figures 4 & 5** for reference. **Note:** To avoid possible water intrusion, it is recommended to use RTV Silicone Adhesive to seal the opening once the wires are fed into the cab.

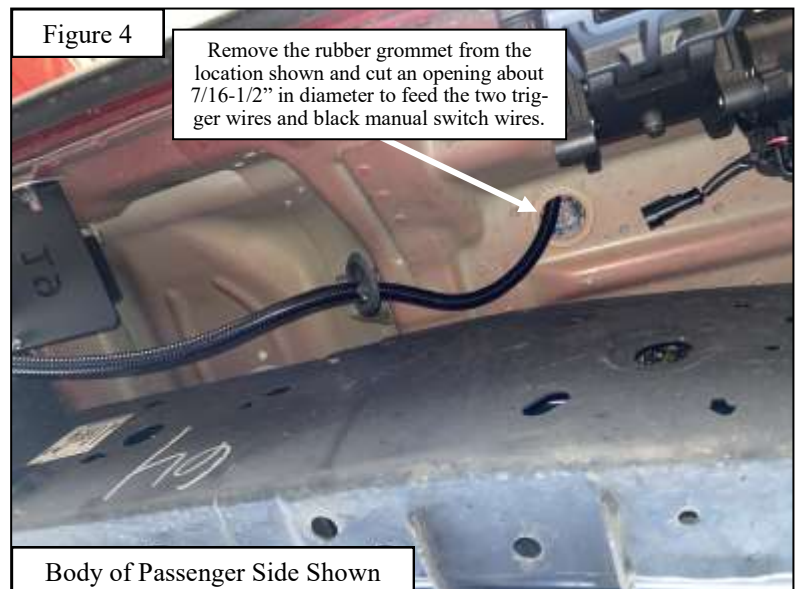
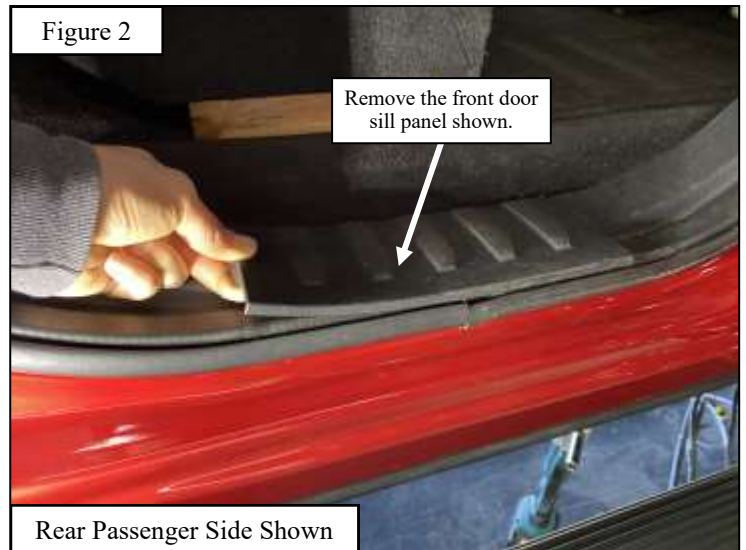

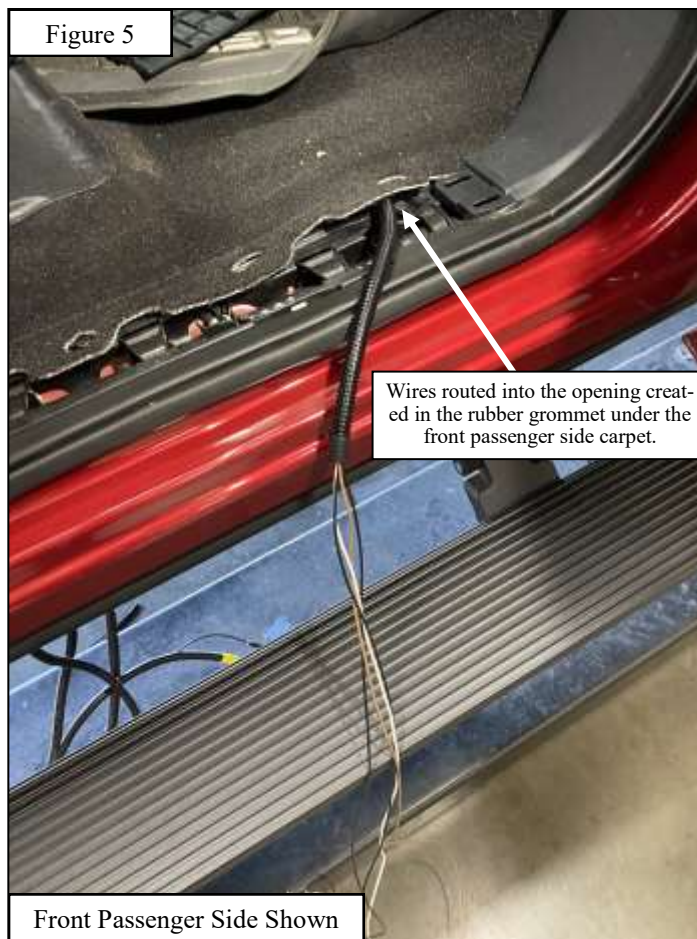

4. Route the passenger side brown door trigger wire to the passenger side B-Pillar, and the driver side white door trigger wire under the front passenger side carpet, the center console, the front driver side carpet, and to the driver side B-Pillar. See **Figures 6 and 7** for reference.
5. With the B-Pillar panels removed, locate the seat belt assembly on the passenger's side and loosen the top bolt shown. Locate the Magnetic Induction Module (Item 9) and mount the ground wire fork under the top bolt of the seat belt assembly to provide a ground connection for the Magnetic Induction Module. Once grounded, connect the snap-in bullet connector on the module to the brown trigger wire previously routed to the passenger side B-Pillar. See **Figure 8 & 9** for reference.
6. Prepare the "sticking" surfaces on both sides of the B-Pillar by using a damp rag with a mix of isopropyl alcohol and water to clean the surface. Once the surface is completely dry, remove the backing from the Magnetic Induction Module, and "stick" them onto both sides of the B-Pillar as shown in **Figures 10 & 11**. **Note:** Pay close attention to where the Magnetic Induction Modules are placed on the door jambs of the vehicle.
7. Using a measuring tape and masking tape, take reference of where the Magnetic Induction Modules have been placed on the front passenger side door jamb and rear passenger side door jamb so that the magnets can be placed accordingly on the door strikers. Once a reference point has been taken, place the reference masking tape onto the passenger side door striker and rear passenger side door striker, respectively, and prepare the surface on the door strikers by using a damp rag with a mix of isopropyl alcohol and water to clean the surface. Once the surface is completely dry, peel the backing from the magnets and "stick" them to the reference location on the door striker. See **Figures 12 & 13** for reference.
8. Repeat **Steps 5 through 7** for the white trigger wire that was previously routed to the driver side B-Pillar.

Note: Pay attention to measurements and positions shown for the Magnetic Induction Module and magnets. The magnet must align with the corresponding module sensor to ensure the motor linkages function properly. *If the boards are not deploying once all of the wiring is connected, inspect and insure that the magnets align with their corresponding module sensor.*

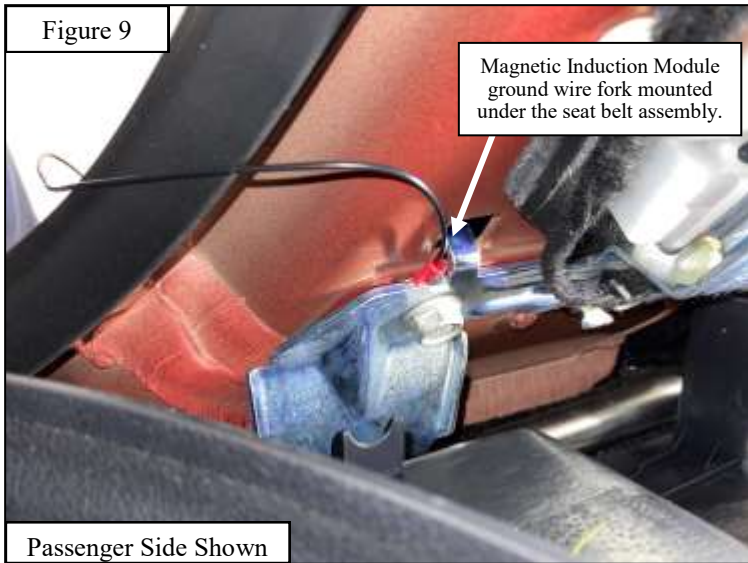
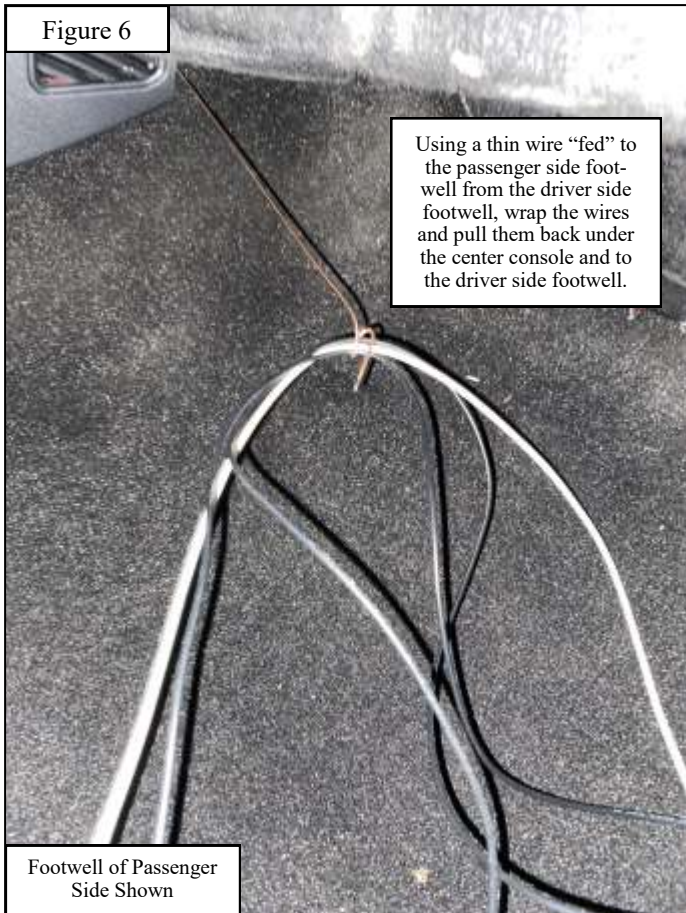

Figure 10



Figure 11

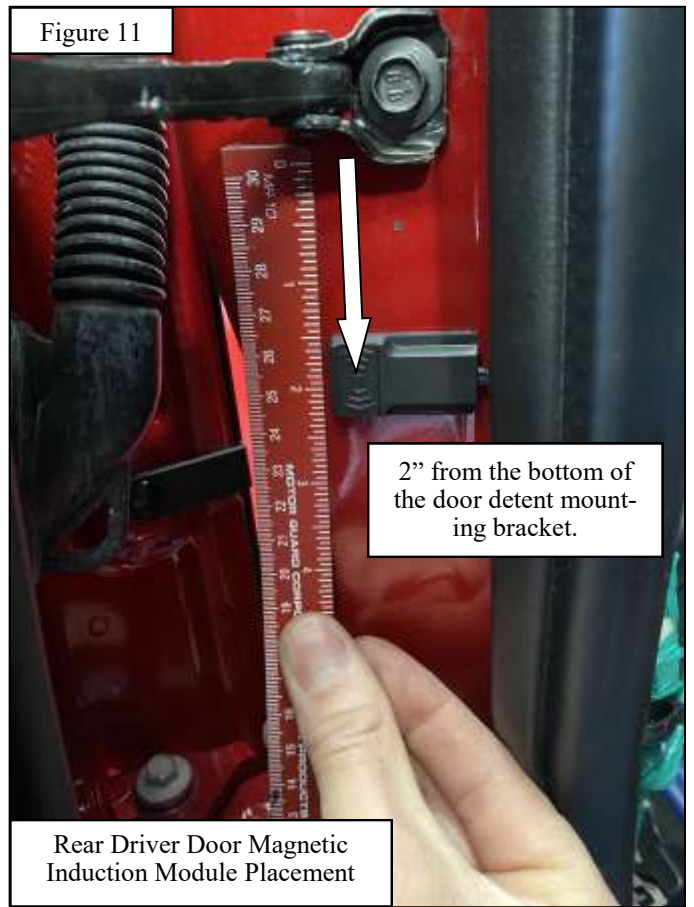

Figure 12



Figure 13



9. Locate the manual switch (Item 8) and prepare the desired mounting surface by using a damp rag with a mix of isopropyl alcohol and water to clean the surface. Once the surface is dry, mount the manual switch to the desired location by removing the backing from the double sided tape and applying pressure to “stick” the switch onto the desired surface. See **Figures 14 & 15** for reference. **Note:** *It is recommended that the manual switch is in an accessible location on the driver’s side lower dash panel.*
10. Route the two black manual switch wires to the manual switch. Connect the two wires and neatly tuck or zip tie the extra wiring away so that the switch cannot be tugged or pulled accidentally. See **Figures 14 & 15** for reference.
11. Moving back to the wiring underneath the vehicle, route the two fused power wires towards the front of the vehicle. Pull back the passenger side fender liner and feed the fused power wires into the engine compartment. Remove the two fuses from both of the fused power wires and leave them disconnected from the battery.

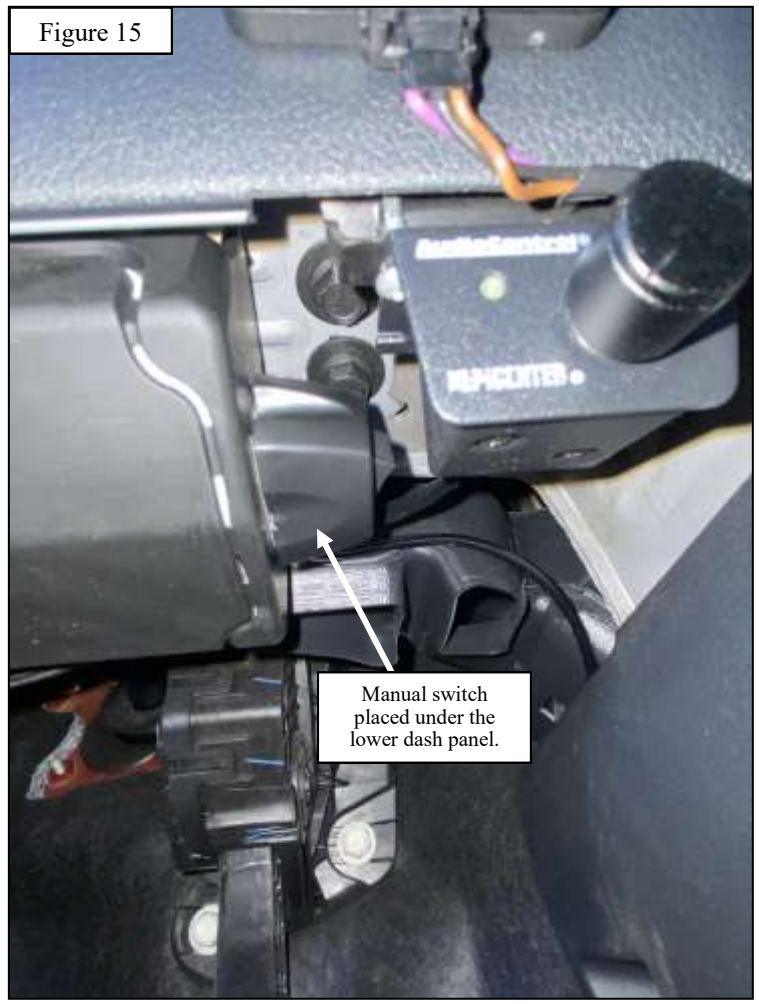

12. Route the electrical harness to the designated locations of the control module and motor linkages. Route the corresponding male connector plug to where the corresponding female connector will be per the labeling on the harness. For example, the male connector labeled “Front Left,” will be routed to the front driver side of the vehicle, and the “Front Right” should be routed to the front passenger side of the vehicle. The male connectors for the control module will be routed to the center drivers side. See **Figures 16 through 19** for reference. **Note:** *The mounting brackets with the female connectors, and the Control Module (Item 6) will be installed after the wiring is routed. For now, the male connectors are only routed to the corresponding locations.*
13. Locate the LED Lights (Item 11). Align the arrow from the LED Light male connector to the arrow on the female connector on the main wiring harness. Prepare the designated mounting surface on the vehicle frame rail or on the body of the vehicle by cleaning it with the provided alcohol wipes, and allow the surface to dry completely before peeling the backing off of the double sided tape and “sticking” the LED lights to the designated mounting surface.

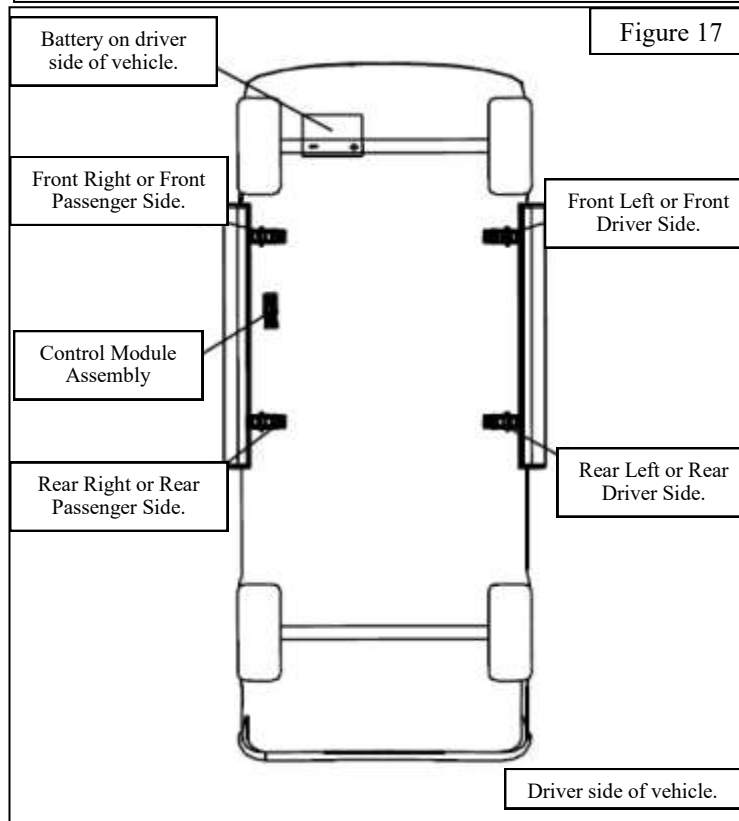
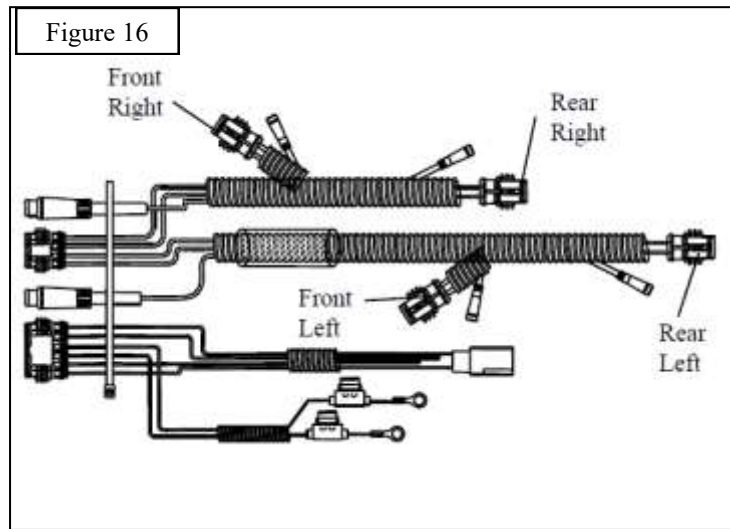

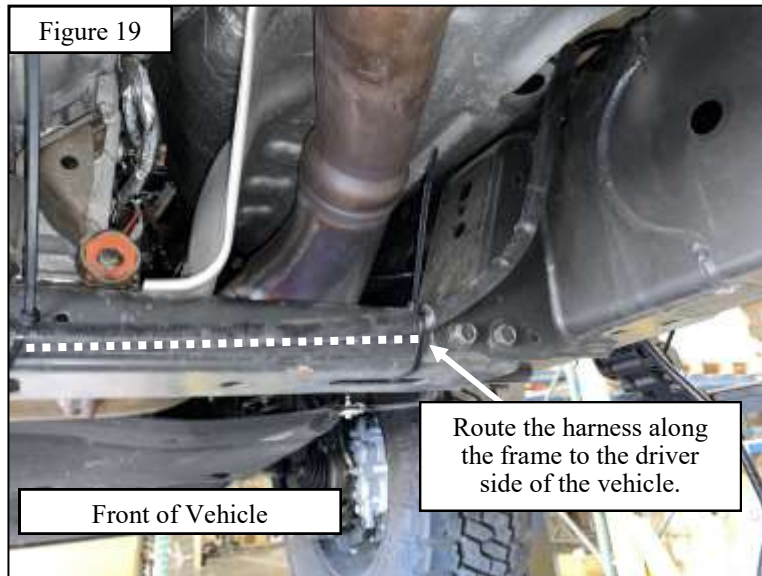
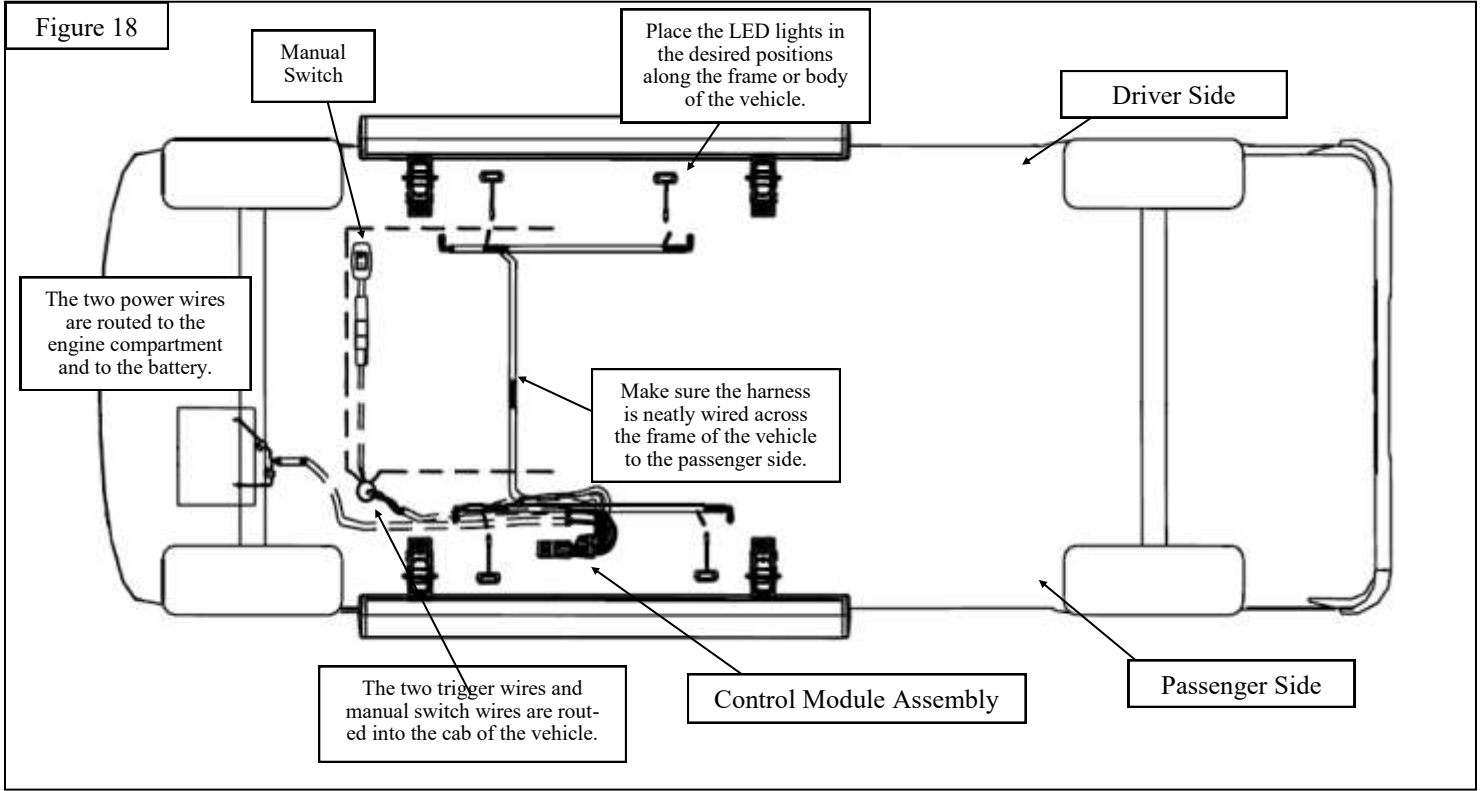

MECHANICAL COMPONENT INSTALLATION PROCEDURE

1. Starting on the driver's side of the vehicle, find the factory studs located on the rocker panel. There should be three mounting studs. See **Figure 20** for reference. **Note:** The Super Crew has three mounting locations and the Super Cab has two mounting locations.

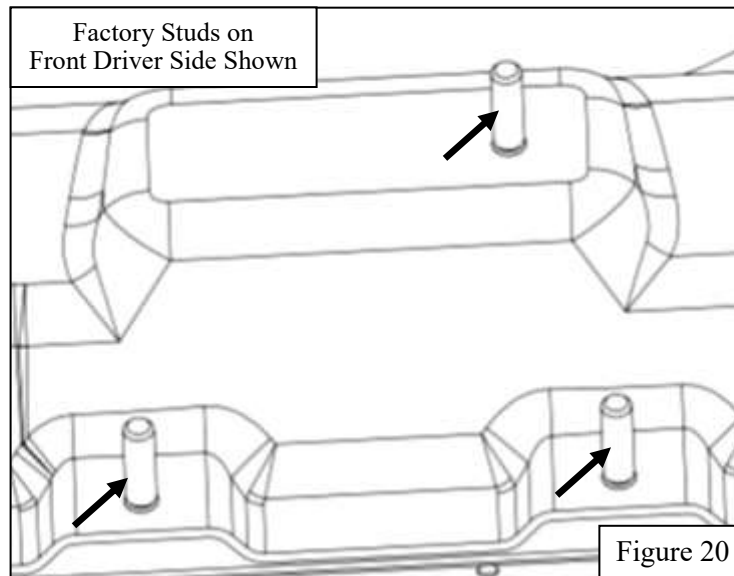

2. On the passenger side of the vehicle, loosely install the Front Motor Linkage (Item 2) to the front rocker panel mounting location using the supplied M8 hardware as shown in **Figures 21 & 22**. Please refer to **Figure 23** for bracket orientation and locations.
3. Loosely install the Control Module Assembly (Item 6) to the center mounting location on the passenger side rocker panel using the supplied M8 hardware as shown in **Figure 24**. Please refer to **Figure 23** for bracket orientation and locations.
4. Loosely install the Rear Motor Linkage (Item 3) to the rear rocker panel mounting location using the supplied M8 hardware as shown in **Figures 25 & 26**. Please refer to **Figure 23** for bracket orientation and locations.

Note: The motor linkages are etched, and call out the corresponding mounting location to help aid with linkage placement.

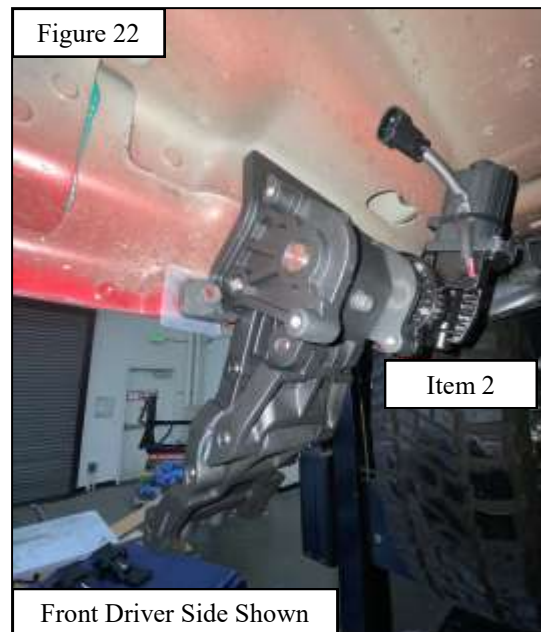
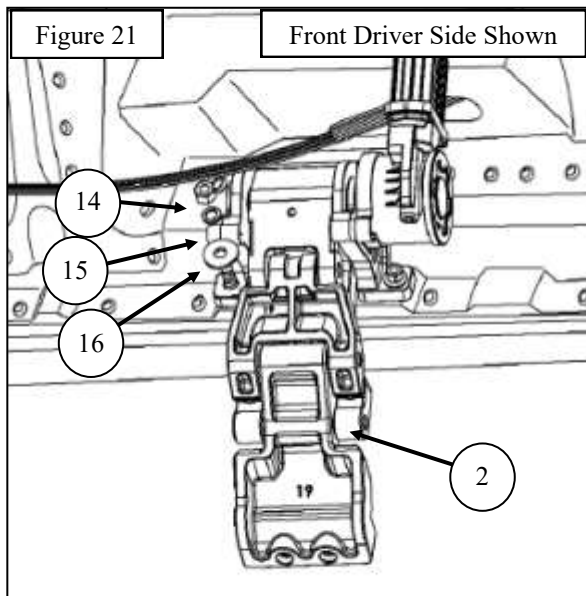

Passenger Side Shown

Figure 23

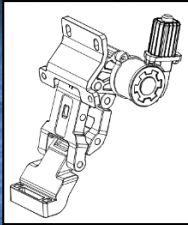
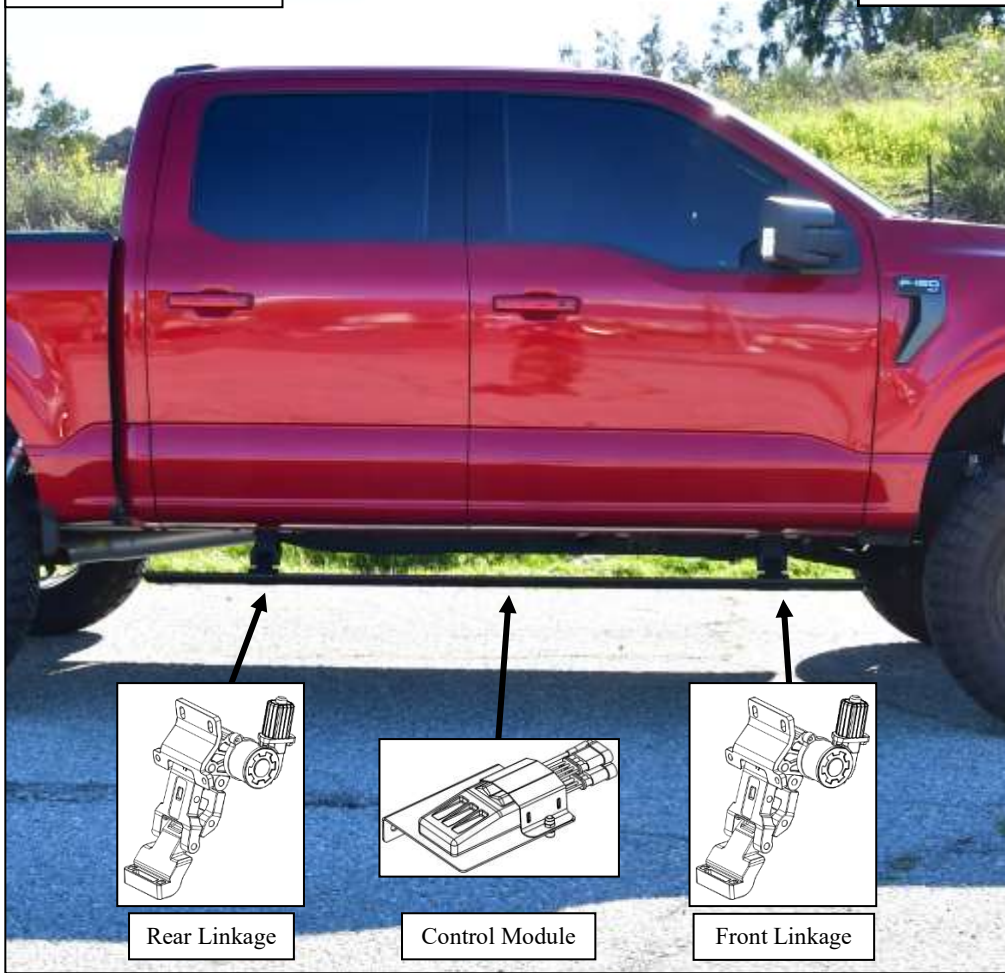

Rear Linkage

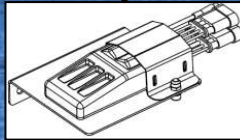

Control Module

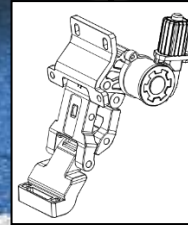

Front Linkage

Figure 24

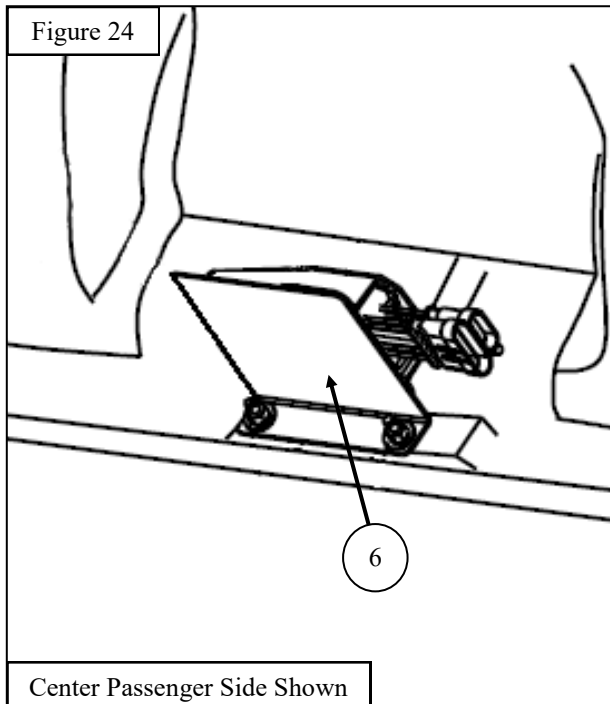

Center Passenger Side Shown

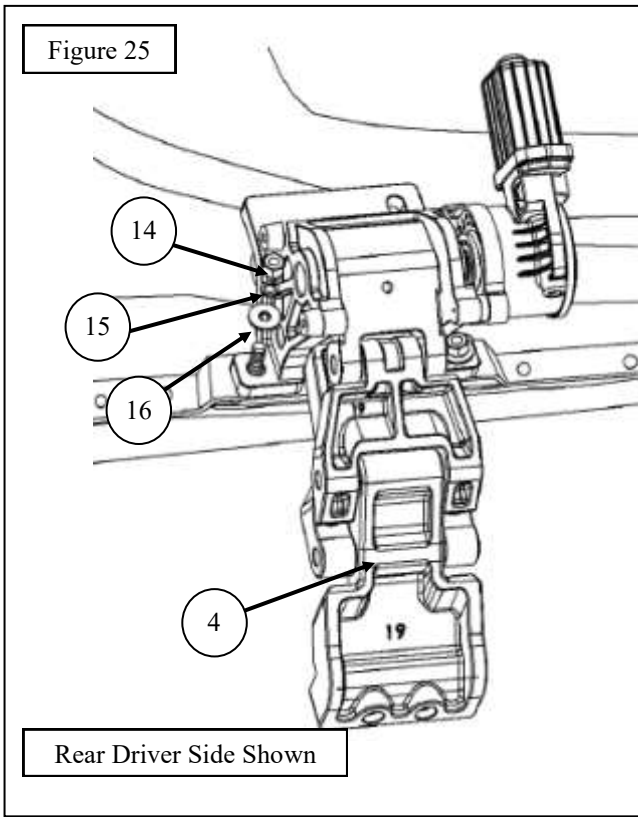

7. With assistance, loosely install one of the running board assemblies (Item 1) to the passenger side of the vehicle. Position the board on the front and rear motor assembly bases, and align the sliding T-Nut on the running board with the corresponding slots on the front and rear motor bases. Once the T-Nuts are aligned, slightly rotate the running board to allow the T-Nuts to set into the slots on the motor bases. See **Figure 27 & 28** for reference.
8. Repeat **Steps 1 through 4, and 6 through 7** for the remaining linkage mounting locations of the vehicle.
9. Align and adjust the both the motor linkage assemblies and the driver and passenger side running boards to the desired positioning. Use the supplied hex socket cap screws (Item 13) to secure the running board to the motor linkage arms. See **Figure 28** for reference.
10. Once all of the components have been adjusted to the desired positioning, fully tighten and torque all hardware as specified: M6 hardware to 8-9 ft-lbs., M8 hardware to 15-18 ft-lbs.

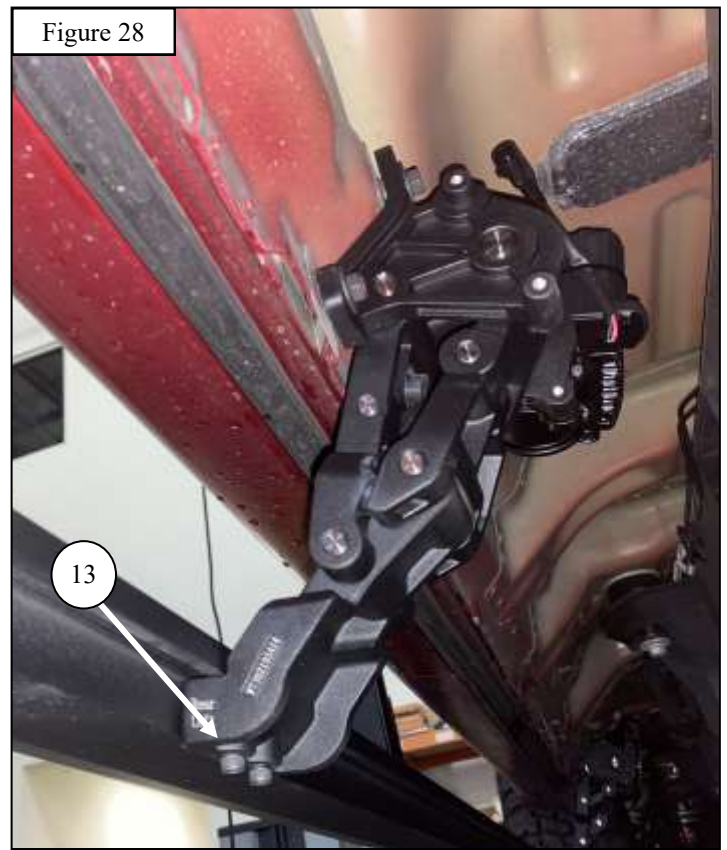

11. Locate and connect the previously routed male connectors from the main wiring harness to the female connectors on each motor linkage assembly. As mentioned previously, the male connector labeled “Front Left” will be connected to the female connector on the front driver side motor linkage, and the “Front Right” male connector should be connected to the female connector on the front passenger side motor linkage.
12. Locate and connect the previously routed four conductor plug, six conductor plug, black two conductor plug, and red two conductor plug to the control module located on the center driver side of the vehicle. With all of the motor linkages, LED Lights, and control module plugs securely connected, return to the two control input wires in the engine compartment. Carefully connect the positive (red wire) to the positive battery terminal and the negative (black wire) to the negative battery terminal. Once the wires are connected to the battery, reinstall the previously removed fuses and neatly tuck away all of the wiring using the provided zip ties (Item 21).

14. With all of the wiring connectors securely plugged in, open the driver side door and ensure that the manual switch is in the off position. This signals the control module to retract and it will disable the operation of the running boards until it switched to the on position.
15. Open and close all of the vehicles doors one by one to ensure that the running boards operate appropriately. If the running boards operate properly, the installation is complete. If they do not, check all the wiring connections and make sure that the magnets on the door striker align with their corresponding control module. **Note:** *The manual switch must be in the “on” position. Additionally, any misalignment between the magnets on the door strikers and their corresponding Magnetic Control Module can prevent the running boards from opening and closing properly.*
16. With the running boards operating properly, neatly tuck away all of the wiring using the provided zip ties (Item 17).

INSTALLATION COMPLETE



CARE INSTRUCTIONS

- REGULAR WAXING IS RECOMMENDED. DO NOT USE ANY TYPE OF POLISH OR WAX THAT MAY CONTAIN ABRASIVES.
- STAINLESS STEEL PRODUCTS CAN BE CLEANED WITH MILD SOAP AND WATER. STAINLESS STEEL POLISH SHOULD BE USED TO POLISH SMALL SCRATCHES.
- GLOSS BLACK FINISHES SHOULD BE CLEANED WITH MILD SOAP AND WATER.

WESTIN Westin Automotive Products, Inc.
320 W. Covina Blvd
San Dimas, Ca. 91773

Thank you for choosing Westin products
for additional installation assistance please call
Customer Service (800) 793-7846
www.westinautomotive.com



WARNING



Failure to follow these instructions could lead to death, personal injury, and / or property damage.

FASTENERS:

All Westin supplied fasteners must be utilized and installed in accordance with the installation instructions and apply torque to the specifications as defined. **DOUBLE CHECK ALL FASTENERS BEFORE INITIAL USE, AND PERIODICALLY IN THE FUTURE TO ENSURE PROPER FUNCTION AND SAFETY.**

DRILLING:

Most Westin products do not require drilling for installation. If drilling is defined as required, use caution when drilling a vehicle. **FAILURE TO REVIEW AN AREA TO BE DRILLED MAY RESULT IN PERSONAL INJURY AND/OR INJURY TO OTHERS AS WELL AS VEHICLE DAMAGE.**

EYE PROTECTION:

ALWAYS WEAR SAFETY GLASSES OR GOGGLES DURING THE INSTALLATION PROCESS TO AVOID PERSONAL INJURY.

MAXIMUM TOWING/CARRYING CAPACITY: (if applicable)

The Westin Receiver Hitches will have a visible tow rating label affixed directly on the product. User should never exceed the vehicle manufacturers maximum tow and weight rating regardless of the capacity of the hitch. **FAILURE TO FOLLOW THESE GUIDELINES WILL VOID THE WESTIN WARRANTY AND MAY RESULT IN PERSONAL INJURY AND/OR INJURY TO OTHERS AS WELL AS VEHICLE DAMAGE.**

FOR CALIFORNIA RESIDENTS ONLY-PROP 65 WARNING:

Some products may contain chemicals such as DEHP, which can cause cancer, birth defects or other reproductive harm. For more info go to www.p65warnings.ca.gov



Westin Automotive Products, Inc.
320 W. Covina Blvd
San Dimas, Ca. 91773