



INSTALLATION INSTRUCTIONS

SURE-GRIP BOARDS & MOLDED STEP BOARDS MOUNT KIT

AUTOMOTIVE PRODUCTS,

APPLICATION:

2014-2017 Chevrolet Silverado / GMC Sierra 1500 Ext./Double/Crew Cab
2015-2017 Chevrolet Silverado / GMC Sierra 2500/3500 HD Double/Crew Cab

PART NUMBER:

Mount Kit: 27-2145

Sure-Grip Boards: 27-6130, 27-6135, 27-6630, 27-6140, 27-6145, 27-6640

Molded Step Boards: 27-0010, 27-0015

Sure-Grip Optional Light Kit: 27-6000

ITEM	QUANTITY	DESCRIPTION	TOOLS NEEDED
1	2	STEP BOARD (SOLD SEPERATELY)	13MM SOCKET
2	2	MOUNT BRACKET A	13MM WRENCH
3	2	MOUNT BRACKET B	RATCHET
4	1	MOUNT BRACKET C	TORQUE WRENCH
5	1	MOUNT BRACKET D	
6	12	M8 HEX HEAD BOLT (YELLOW ZINC)	
7	6	M8 HEX NUT (YELLOW ZINC)	
8	6	M8 EXTRUDED U-NUT (YELLOW ZINC)	
9	12	M8 SQUARE HEAD BOLT (YELLOW ZINC)	
10	30	M8 FLAT WASHER (YELLOW ZINC)	
11	12	M8 LOCK WASHER (YELLOW ZINC)	
12	12	M8 LOCK NUT (YELLOW ZINC)	

ANTI-SEIZE LUBRICANT MUST BE USED ON ALL STAINLESS STEEL FASTENERS TO PREVENT THREAD DAMAGE AND GALLING

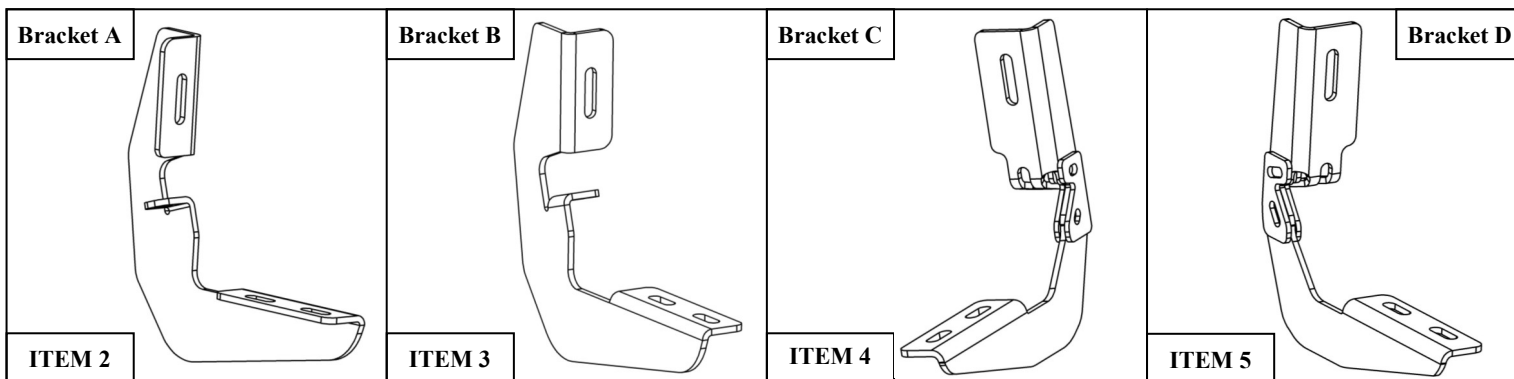

PROCEDURE

1. Remove contents from box, verify if all parts listed are present and free from damage.
Carefully read and understand all instructions before attempting installation.
Failure to identify damage before installation could lead to a rejection of any claim.



Westin Automotive Products, Inc.
320 W. Covina Blvd
San Dimas, Ca. 91773

2. Locate, on both rocker panel sides, black rubber plugs and remove them, see **FIGURE 7**. Install M8 U-nut clips (Item 8) as shown in **FIGURE 7**. Take the mounting brackets and install the brackets loosely to the corresponding mount locations, see **FIGURE 8**. Brackets used for the passenger side are (1) Bracket C (Item 4), (1) Bracket D (Item 5) and (1) Bracket B (Item 3). Driver side will use brackets (1) Bracket B and (2) Bracket A (Item 2). Installation procedure for driver side is same as passenger side. Do not fully tighten at this time.

Note: On 1500 Crew Cab models, front positions will have a welded nut on pinch weld and must refer to FIGURE 9 for bracket installation.

For 2015-2016 Diesel equipped models, the D.E.F tank must be removed prior to installing the front brackets on the passenger side. For D.E.F tank removal instructions, please refer to page 5. Note: Bracket location is critical.

3. Insert square head bolts as shown (2 per slot, 4 per board). SEE **FIGURES 2 AND 3**.

NOTE: For lighted boards, route wiring harness prior to attaching the board to the brackets (refer to Step 5). SEE FIGURES 2 AND 3. Run the longer wire harness on the passenger side.

4. For Sure-Grip Running Boards, slide Sure Grip Gap strip as shown. Set lights (optional) in appropriate location. Attach to Sure-Grip Running Board as shown. SEE **FIGURE 2**. Drill hole through plastic strip and run wires as shown. SEE **FIGURE 4**.
5. Attach board to brackets as shown. Make sure board and brackets are properly aligned and tighten fasteners. Recommended torque values are 10 FT.LBS. for M8 square head fasteners and 18 FT.LBS. for M8 hex head bolt. SEE **FIGURE 5**.

NOTE: For lighted version of Step board, remove plastic cover from each end of under side of Step board.

WARNING: INSTALLING LIGHT HARNESS REQUIRES SPLICING INTO VEHICLES ELECTRICAL SYSTEM. WESTIN RECOMMENDS USING A PROFESSIONAL FOR THIS INSTALLATION. NOTE: AVOID AREAS OF EXCESSIVE HEAT, VIBRATION, PINCH OR ROTATION WHEN SECURING HARNESS TO VEHICLE. CAUTION: ALWAYS USE A FUSED(+) POSITIVE SUPPLY SOURCE. UNDERCOAT SEAL FOR HARSH WEATHER.

HINT: Step boards: For Longevity, check rubber seals before installation. Rubber grommets around red and blue wires going into rear sockets, should be inserted and recessed about 1/4". **NOTE:** Remove bulbs and apply white grease into sockets and replace bulbs. Apply RTV Silicone where lights go into socket. Install lights and run wire loom as shown. SEE **FIGURE 3**. For Sure-Grip Running Boards, run wire loom down center as shown. SEE **FIGURE 2**.

6. Determine whether your vehicle has a positive or negative switching courtesy system or an auxiliary light source (most Fords). Obtain an accurate wiring diagram for your vehicle's courtesy light system.

For positive and negative switching:

Locate a pass-through point (usually under carpet at driver side door sill) for the wire harness. Locate main courtesy wire (usually wire lead to dome light). **NOTE:** If you do not use the main courtesy wire, lights will only function when one door is open. Route wire harness so that the 2 female connections (from step board) are nearest to pass thru point. *Connect opposite step board lead to either connection. Connect the splicing lead to remaining female socket and route one wire thru pass thru point. SEE **FIGURE 6**.

VERY IMPORTANT - Double check that your system has positive or negative switching.

For positive switching only: Connect positive wire to main courtesy system, (usually wire lead to dome light). TEST CONTINUITY BEFORE CONNECTING BY OPENING AND CLOSING ALL DOORS. Ground remaining wire.

For negative switching only: Connect negative wire to main courtesy system, (usually wire lead to dome light but sometimes from dome light to courtesy ECU). TEST GROUND CONTINUITY BEFORE CONNECTING BY OPENING AND CLOSING ALL DOORS. Connect remaining wire to battery using a 5A fuse.

****Be sure that you have not routed any wires near moving parts (i.e.. driveshaft) or near any heat generating source (i.e.. transmission, engine, exhaust).**

Auxiliary Light source:

Locate auxiliary light source connection under vehicle, usually attached to back side of front or rear fender well (refer to vehicles owners manual). SEE **FIGURE 6**. TEST SOURCE BEFORE CONNECTING. Connect splicing leads to aux light source. test step board lights for proper function by opening and closing doors.

7. Under-coat board, brackets and electrical wires, connections and lenses for harsh weather conditions. Reinstall plastic cover on underside of Step .
8. Proceed to re-install D.E.F tank on 11-16 diesel models.



Westin Automotive Products, Inc.
320 W. Covina Blvd
San Dimas, Ca. 91773

Thank you for choosing Westin products
for additional installation assistance please call
Customer Service (800) 793-7846

www.westinautomotive.com

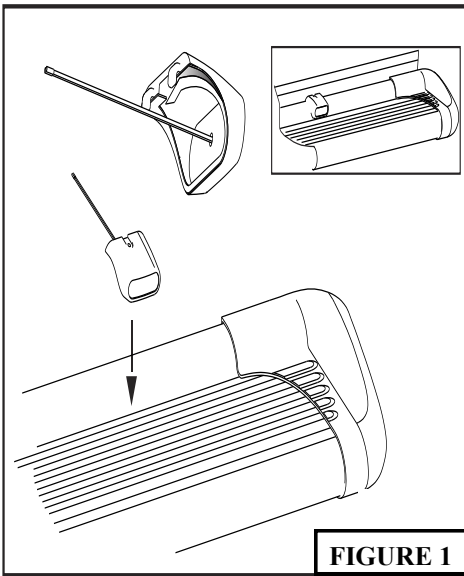

FIGURE 1

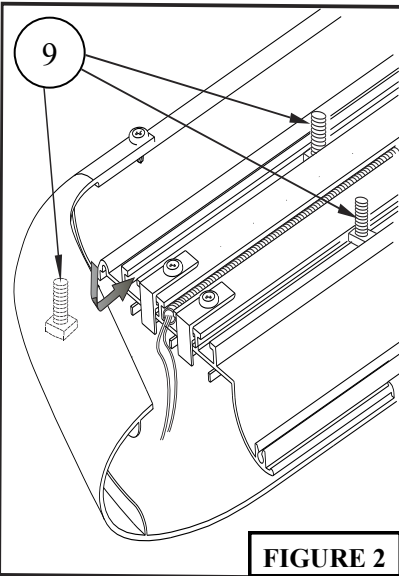

FIGURE 2

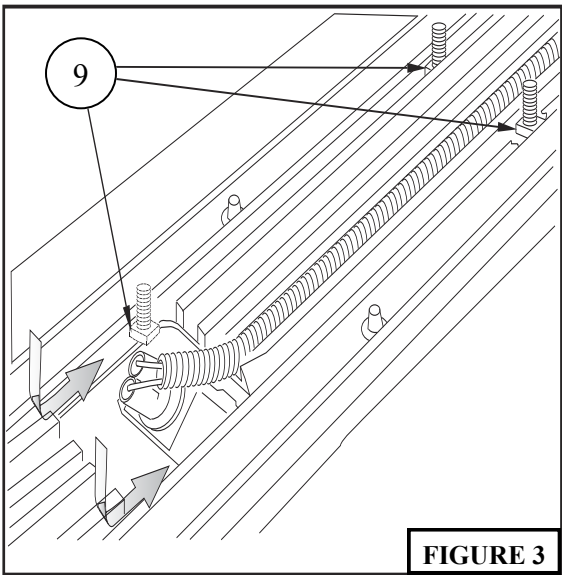

FIGURE 3

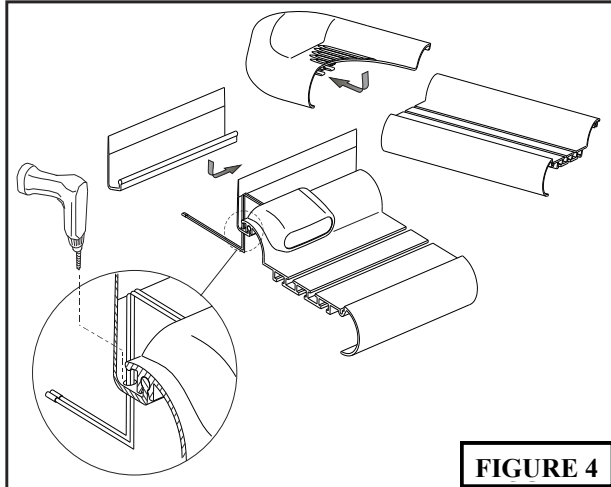

FIGURE 4

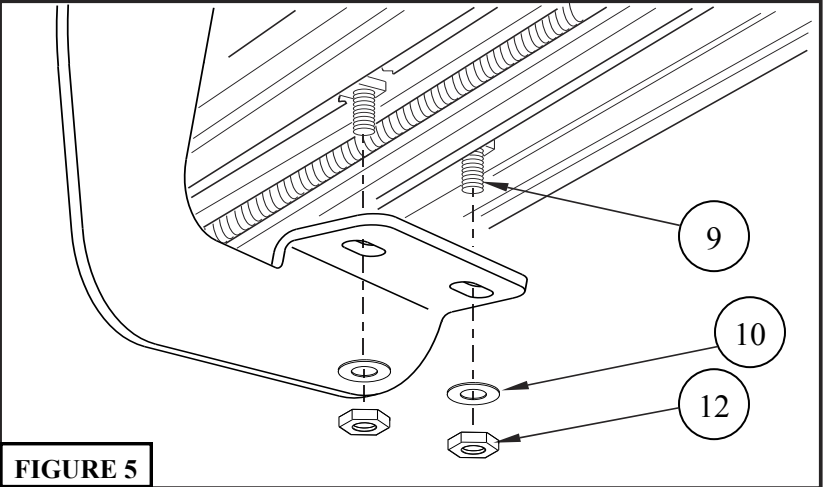

FIGURE 5

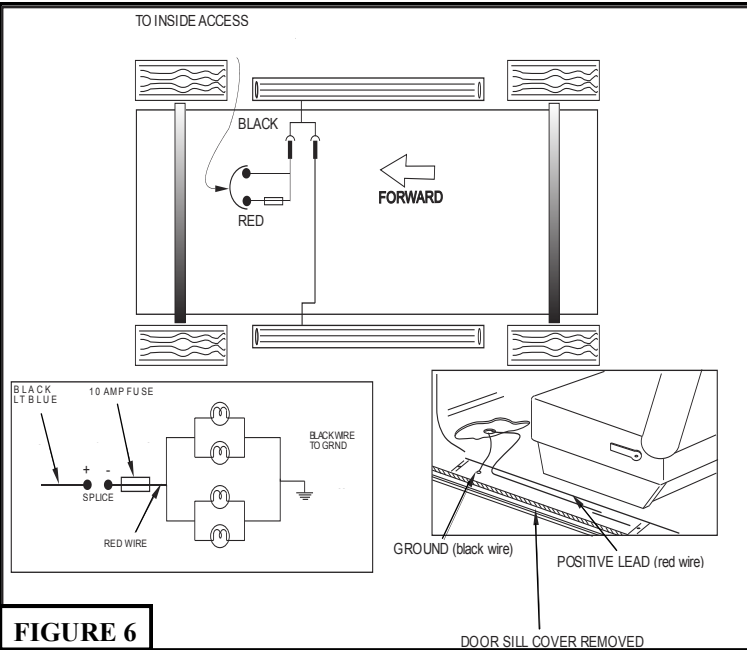

FIGURE 6

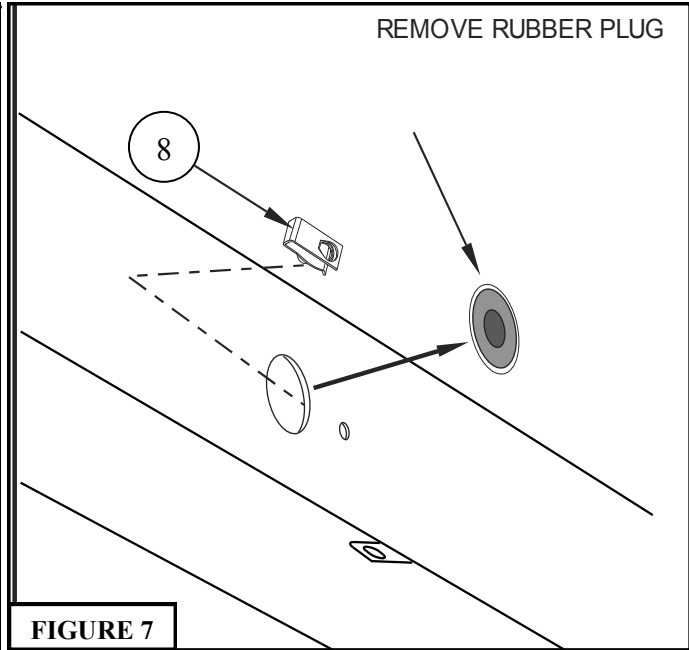
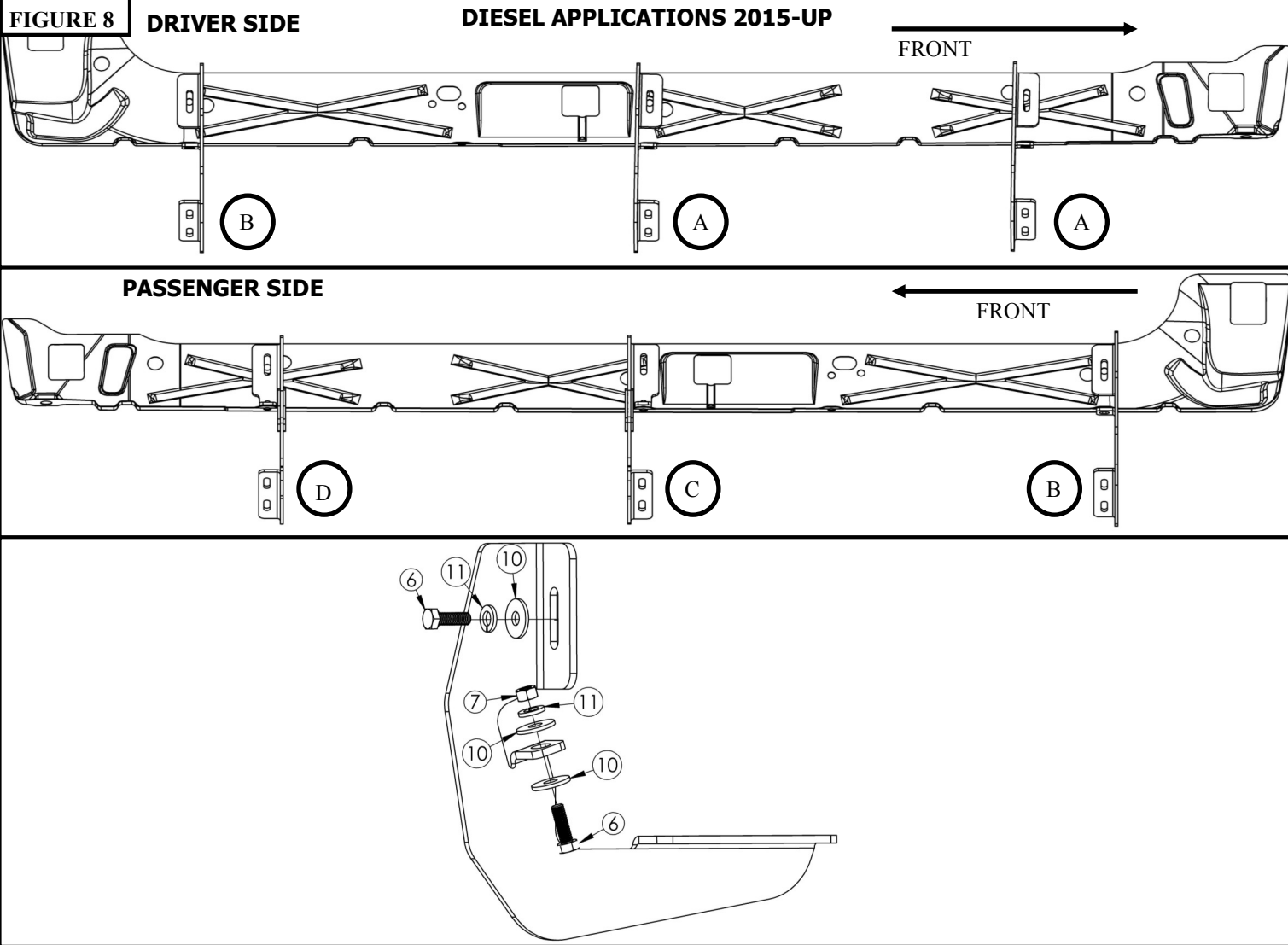

FIGURE 7



Westin Automotive Products, Inc.
320 W. Covina Blvd
San Dimas, Ca. 91773

Thank you for choosing Westin products
for additional installation assistance please call
Customer Service (800) 793-7846



Westin Automotive Products, Inc.
 320 W. Covina Blvd
 San Dimas, Ca. 91773

Thank you for choosing Westin products
 for additional installation assistance please call
 Customer Service (800) 793-7846
 www.westinautomotive.com

DEF TANK REMOVAL INSTRUCTIONS FOR 11-15 DIESEL MODELS ONLY

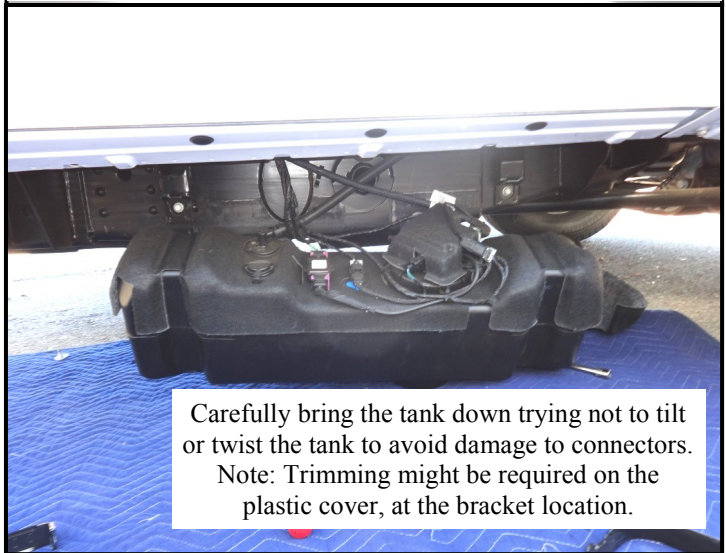
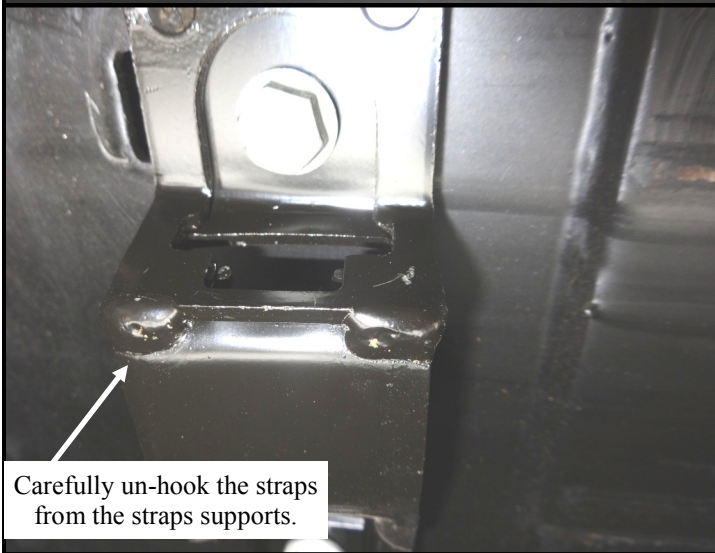
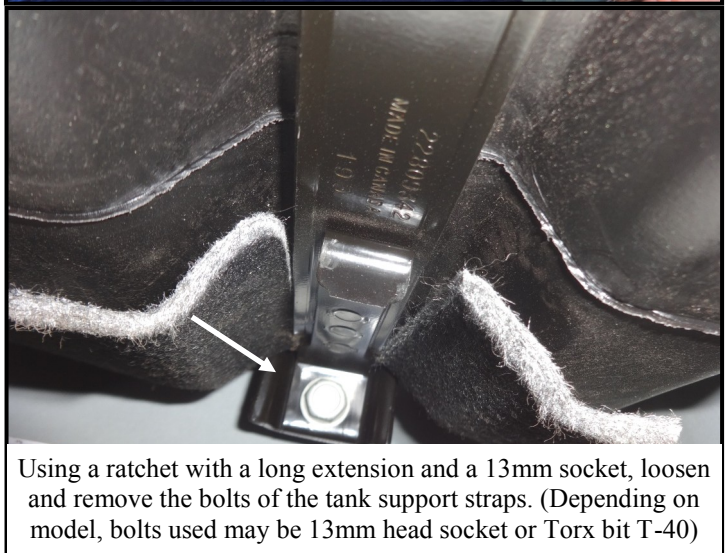
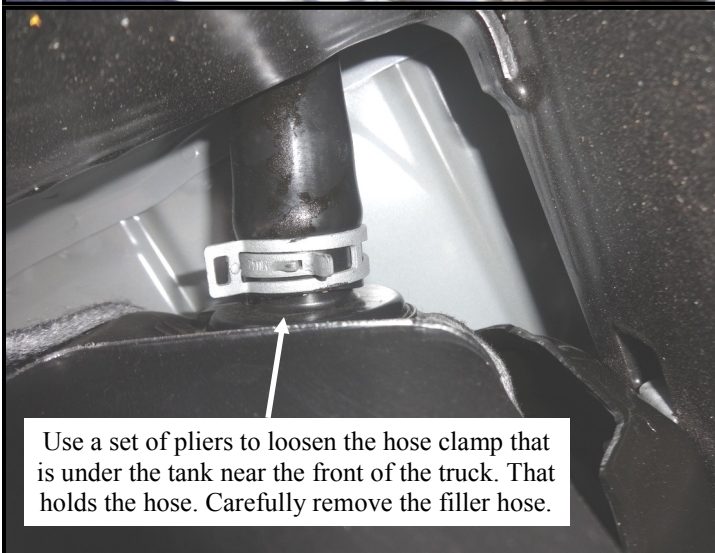
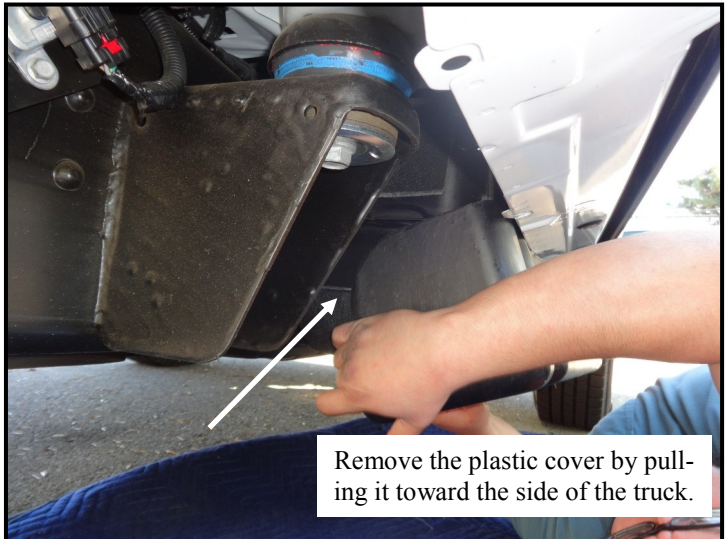
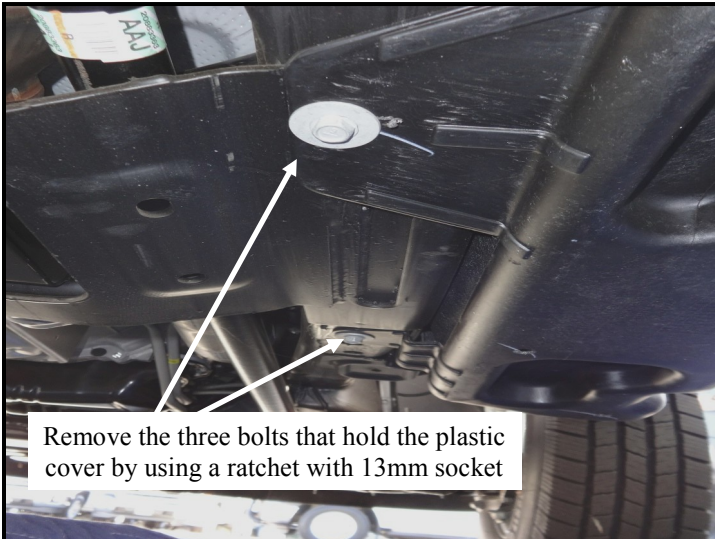

Westin Automotive Products, Inc.
320 W. Covina Blvd
San Dimas, Ca. 91773

Thank you for choosing Westin products
for additional installation assistance please call
Customer Service (800) 793-7846
www.westinautomotive.com

Westin

SIGNATURE OF QUALITY

AUTOMOTIVE PRODUCTS, INC.



WARNING



Failure to follow these instructions could lead to death, personal injury, and / or property damage.

FASTENERS:

All Westin supplied fasteners must be utilized and installed in accordance with the installation instructions and apply torque to the specifications as defined. **DOUBLE CHECK ALL FASTENERS BEFORE INITIAL USE, AND PERIODICALLY IN THE FUTURE TO ENSURE PROPER FUNCTION AND SAFETY.**

DRILLING:

Most Westin products do not require drilling for installation. If drilling is defined as required, use caution when drilling a vehicle. **FAILURE TO REVIEW AN AREA TO BE DRILLED MAY RESULT IN PERSONAL INJURY AND/OR INJURY TO OTHERS AS WELL AS VEHICLE DAMAGE.**

EYE PROTECTION:

ALWAYS WEAR SAFETY GLASSES OR GOGGLES DURING THE INSTALLATION PROCESS TO AVOID PERSONAL INJURY.

MAXIMUM TOWING/CARRYING CAPACITY:

The Westin Receiver Hitches will have a visible tow rating label affixed directly on the product. User should never exceed the vehicle manufacturers maximum tow and weight rating regardless of the capacity of the hitch. **FAILURE TO FOLLOW THESE GUIDELINES WILL VOID THE WESTIN WARRANTY AND MAY RESULT IN PERSONAL INJURY AND/OR INJURY TO OTHERS AS WELL AS VEHICLE DAMAGE.**

Westin
SIGNATURE OF QUALITY

Westin Automotive Products, Inc.
320 W. Covina Blvd
San Dimas, Ca. 91773