

INSTALLATION INSTRUCTIONS

OUTLAW FRONT BUMPER



APPLICATION:
2015 - 2017 Ford F-150
PART NUMBER:
58-61015

CONTENT			
ITEM	QUANTITY	DESCRIPTION	TOOLS NEEDED
1	1	OUTLAW FRONT BUMPER	13MM SOCKET
2	1	SKID PLATE	RATCHET
3,4	2	MESHED CORNER COVER, DRIVER (3) AND PASSENGER (4)	5MM ALLEN
5,6	2	FRAME BRACKET, DRIVER (5) AND PASSENGER (6)	TORQUE WRENCH
7,8	2	LED SLIDER BRACKET, DRIVER (7) AND PASSENGER (8)	15MM SOCKET
9,10	2	LED L-BRACKET, DRIVER (9) AND PASSENGER (10)	19MM SOCKET
11	2	MESHED SIDE LED COVER	19MM WRENCH
12	3	M8 U-CLIPS (BLACK ZINC)	
13	4	SHORT M8 BUTTON HEAD BOLT (BLACK ZINC)	
14	3	LARGE M8 FLAT WASHER (BLACK ZINC)	
15	10	M12 SERRATED FLANGE HEX HEAD BOLT (BLACK ZINC)	
16	10	M12 HEX NUT (BLACK ZINC)	
17	10	M12 FLAT WASHER (BLACK ZINC)	
18	10	M12 SPLIT LOCK WASHER (BLACK ZINC)	
19	8	M8 CAIRRAGE SCREWS (BLACK ZINC)	
20	8	M8 HEX NUT (BLACK ZINC)	
21	11	M8 SPLIT LOCK WASHER (BLACK ZINC)	
22	3	LONG M8 BUTTON HEAD BOLT (BLACK ZINC)	
23	12	SMALL M8 FLAT WASHER (BLACK ZINC)	
24	4	M8 SERRATED FLANGE HEX NUT (BLACK ZINC)	

ANTI-SEIZE LUBRICANT MUST BE USED ON ALL STAINLESS STEEL FASTENERS TO PREVENT THREAD DAMAGE AND GALLING

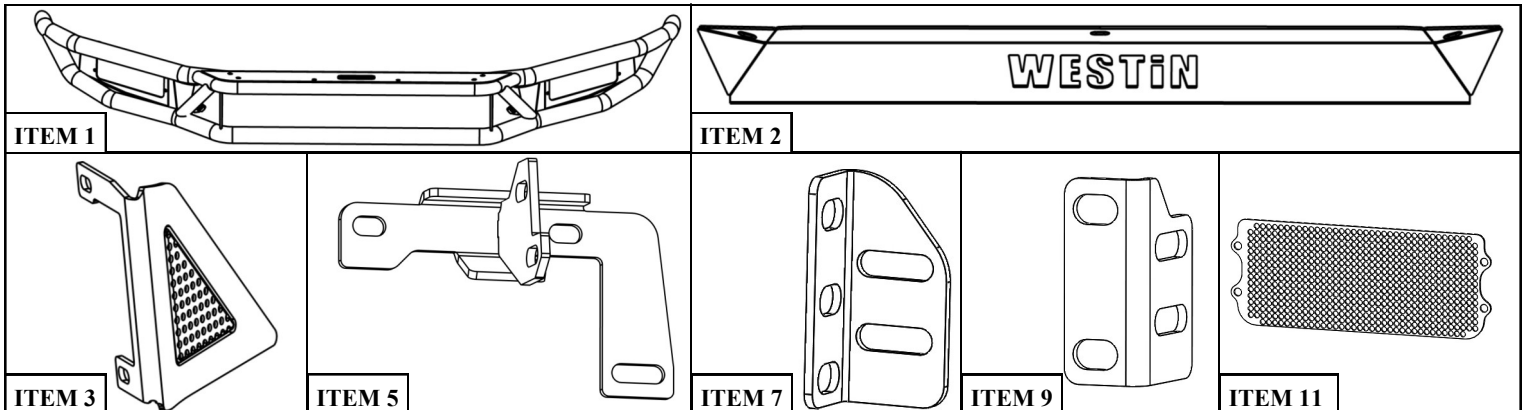

WESTiN Westin Automotive Products, Inc.
320 W. Covina Blvd
San Dimas, Ca. 91773

Thank you for choosing Westin products
for additional installation assistance please call
Customer Service (800) 793-7846

PROCEDURE

1. Remove contents from box, verify if all parts listed are present and free from damage.
Carefully read and understand all instructions before attempting installation.
Failure to identify damage before installation could lead to a rejection of any claim.



2. Remove plastic caps from stock bumper. See **Figure 1**.
3. Remove the three bolts indicated in **Figures 2 & 3** from each side of the vehicle.
4. Remove original bumper making sure to disconnect any electrical connections to the bumper.

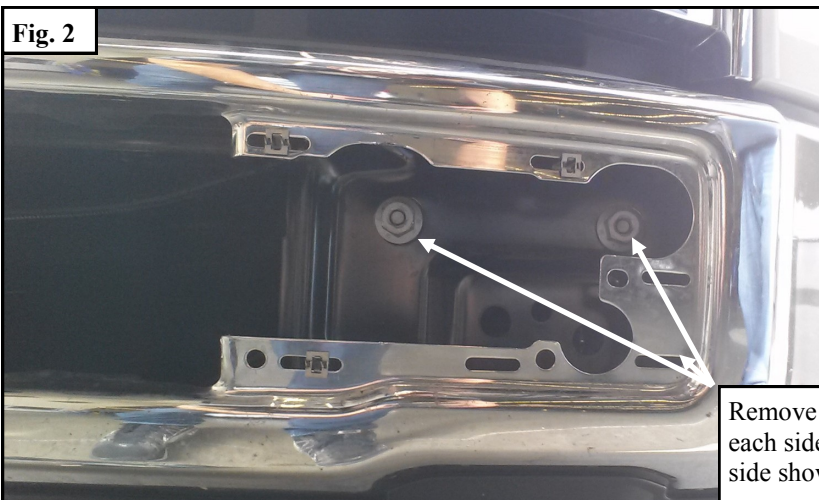

Remove bolts from each side. Driver side shown.

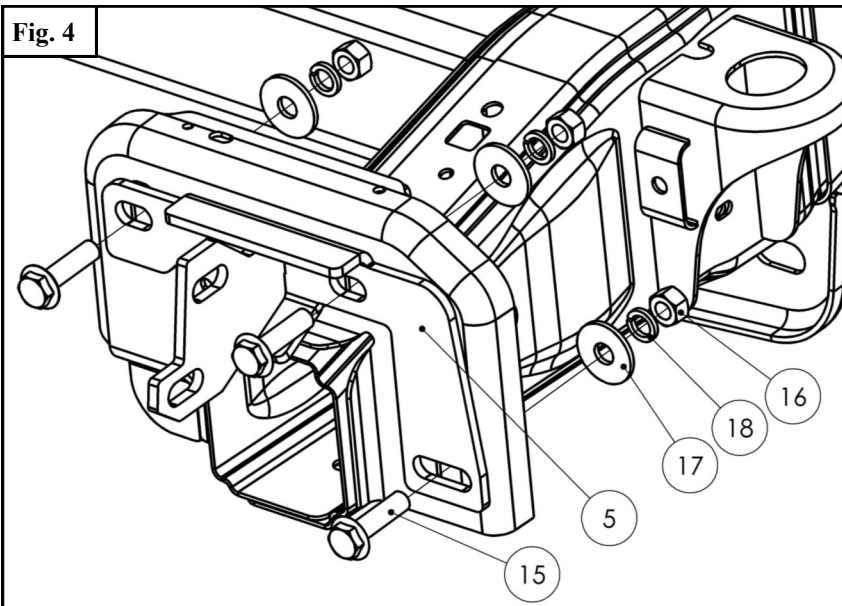
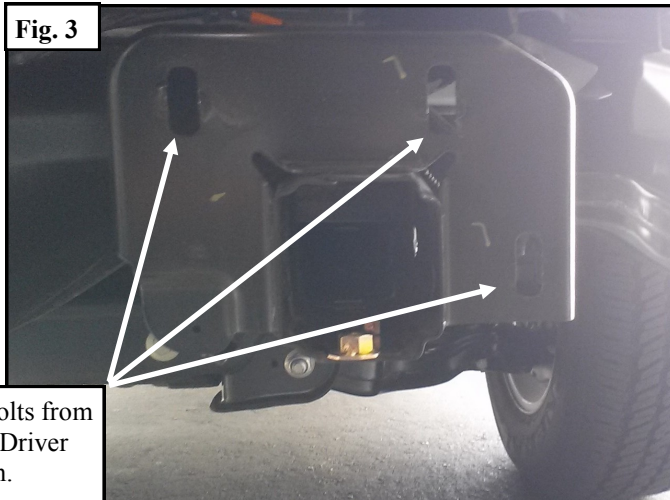

5. Loosely install frame brackets (5 & 6) using the supplied M12 hardware. **Note:** Driver side shown. See **Figure 4**.

WESTIN

Westin Automotive Products, Inc.
320 W. Covina Blvd
San Dimas, Ca. 91773

6. Proceed to install center light bar brackets (and light bar (s)). Items 7-10 can be mounted in different configurations in order to have the necessary adjustment for various “30” inch light bar overall lengths. See **Figure 5-7**.

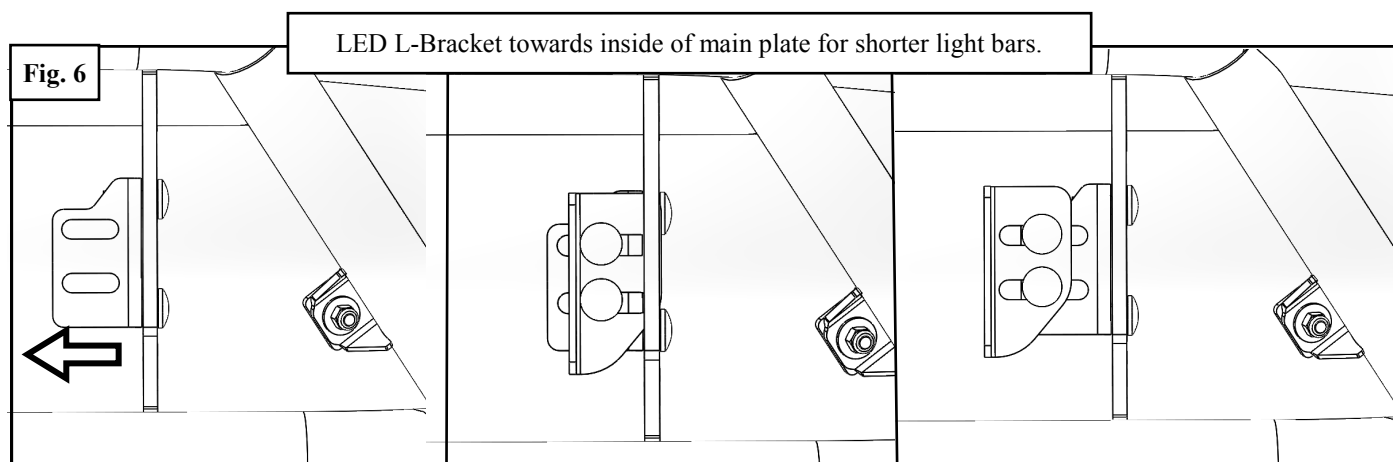
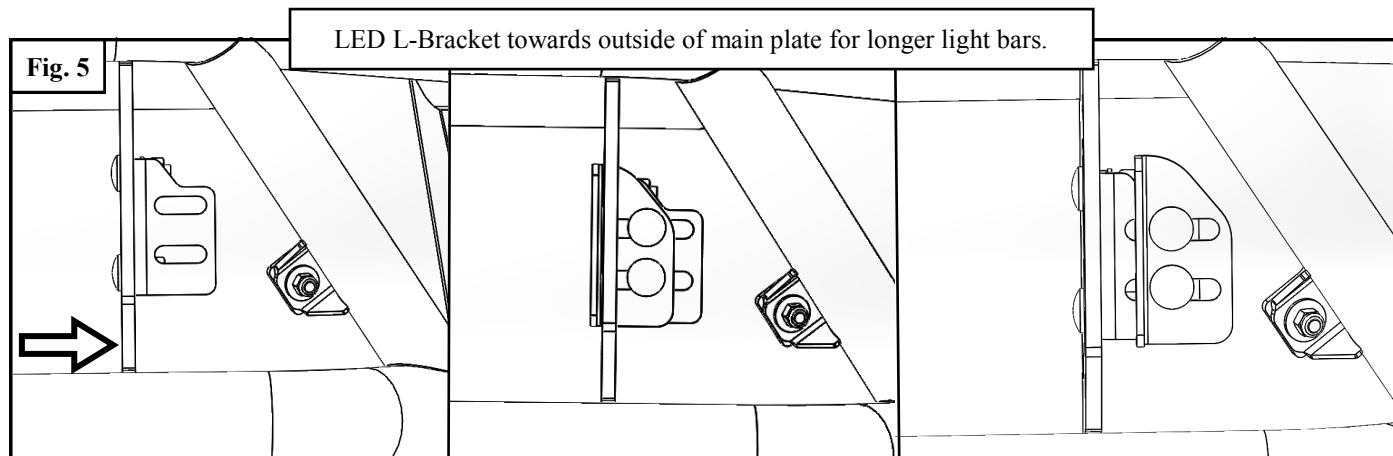

Figure 7 is an example that shows the LED brackets towards the inside adjusted in for the shortest light bar configuration.

CARE INSTRUCTIONS

- REGULAR WAXING IS RECOMMENDED. DO NOT USE ANY TYPE OF POLISH OR WAX THAT MAY CONTAIN ABRASIVES
- STAINLESS STEEL PRODUCTS CAN BE CLEANED WITH MILD SOAP AND WATER. STAINLESS STEEL POLISH SHOULD BE USED TO POLISH SMALL SCRATCHES.
- GLOSS BLACK FINISHES SHOULD BE CLEANED WITH MILD SOAP AND WATER

WESTIN Westin Automotive Products, Inc.
320 W. Covina Blvd
San Dimas, Ca. 91773

Thank you for choosing Westin products
for additional installation assistance please call
Customer Service (800) 793-7846
www.westinautomotive.com

7. Using items 23, 19, 20, and 21 fasten LED L-Brackets (9 & 10) to main plate. Do not tighten. See **Figure 8**.
8. Using items 23, 19, 20, and 21 fasten LED Slider Bracket (7 & 8) to LED L-Bracket. Do not tighten. See **Figure 9**.
9. Using hardware included in the LED light bar hardware kit, fasten to bracket according to **Figures 10 & 11**.
10. Position light bar as desired and tighten all M8 hardware to 15-18 ft-lbs.

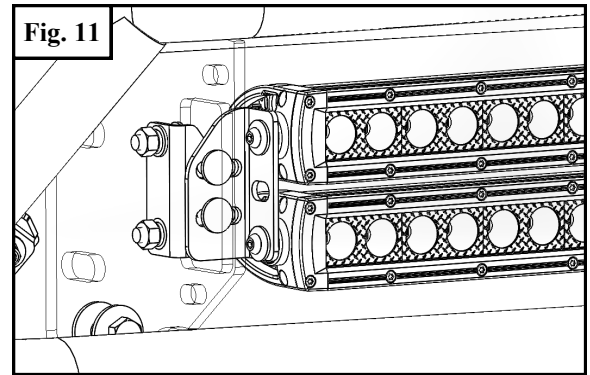
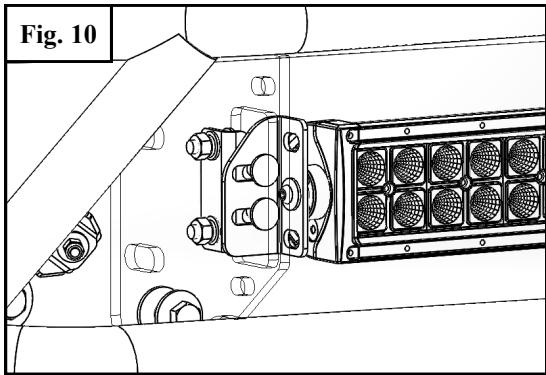
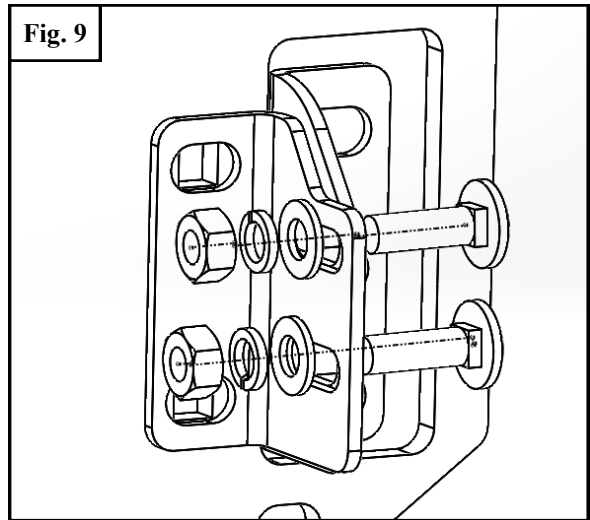
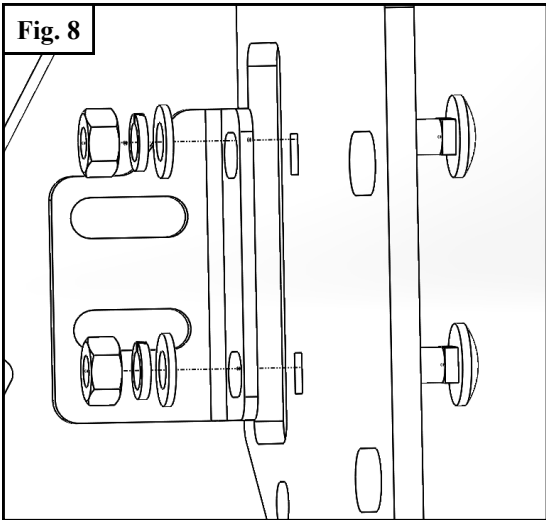

Single "Double Row" Light Bar Configuration

Double "Single Row" Light Bar Configuration

11. Position the meshed corner covers (3 & 4) as seen in **Figures 12 & 13**.

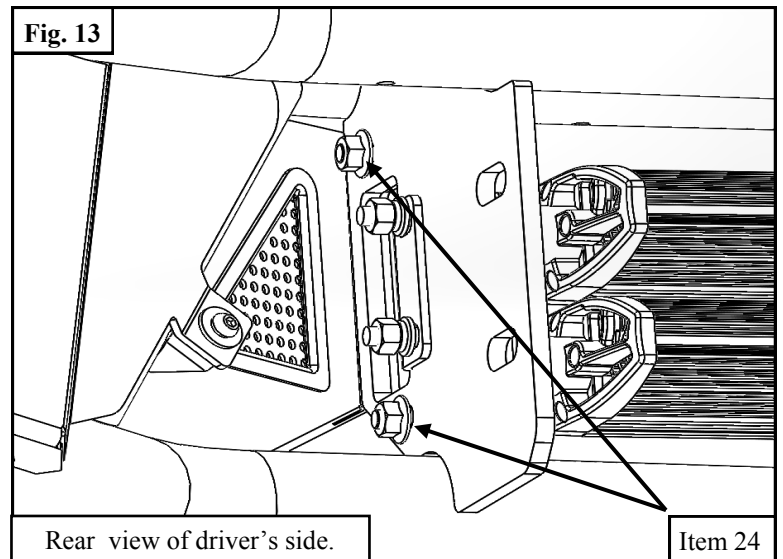
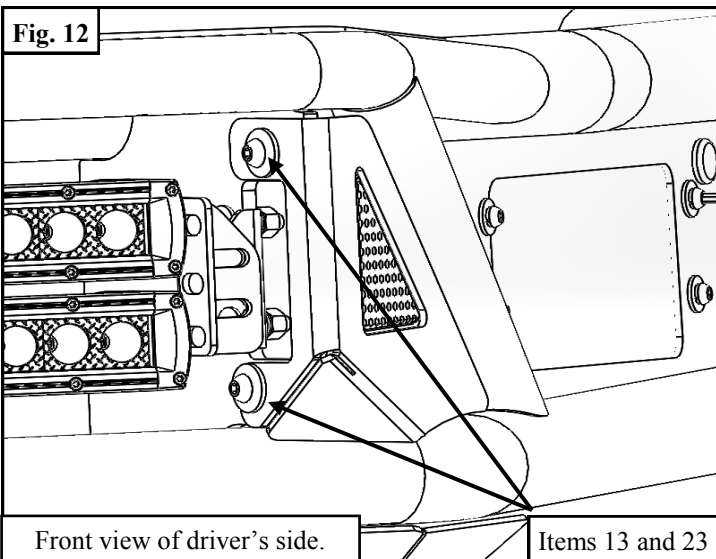

Front view of driver's side.

Items 13 and 23

Rear view of driver's side.

Item 24

12. Using M8 serrated flange hex nuts (24), fasten corner cover into position. The serration on the nut should lock the nut in position allowing the installer to tighten button head bolts from the front using a 5mm Allen wrench. See **Figure 13**.
13. Using supplied M12 hardware (15-18), mount bumper to frame brackets according to **Figures 14-16**.
14. Torque all M12 hardware to 50-55 ft-lbs.

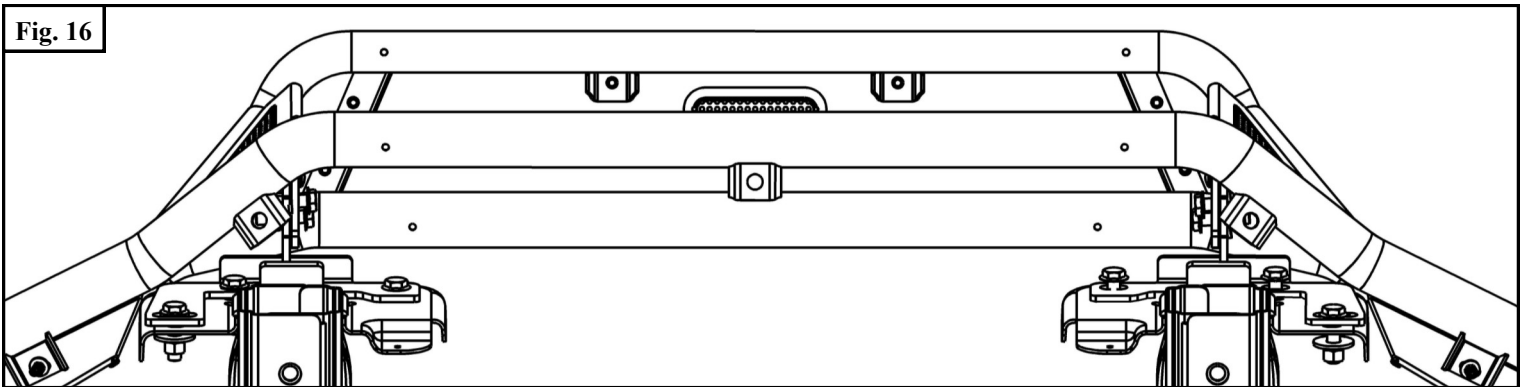
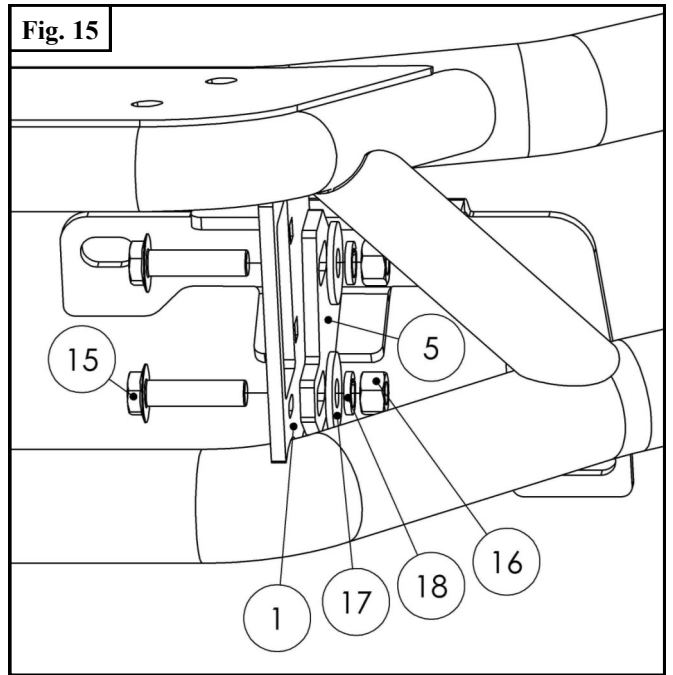
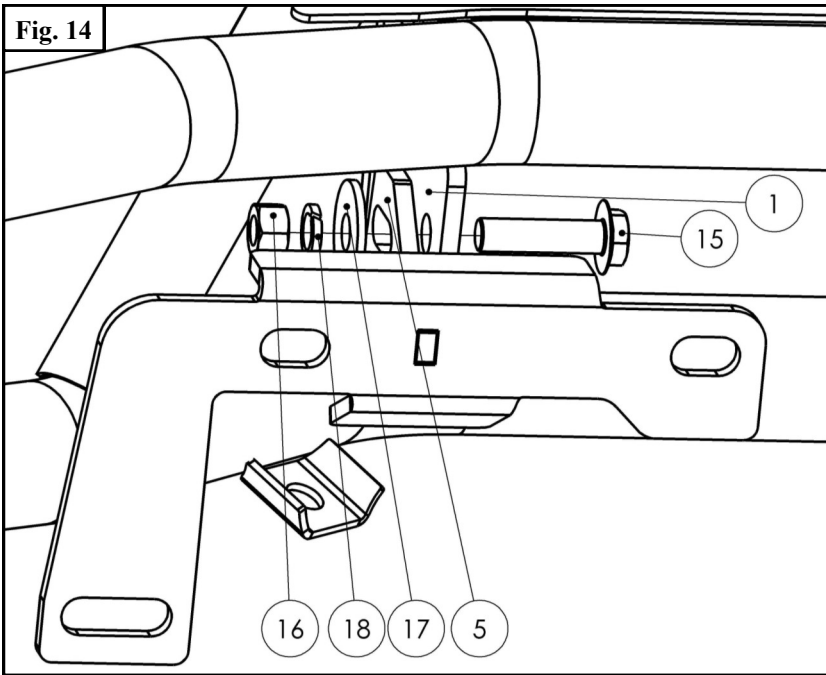

15. Install M8 U-clips (12) the tabs on lower tube of bumper according to **Figure 17**.

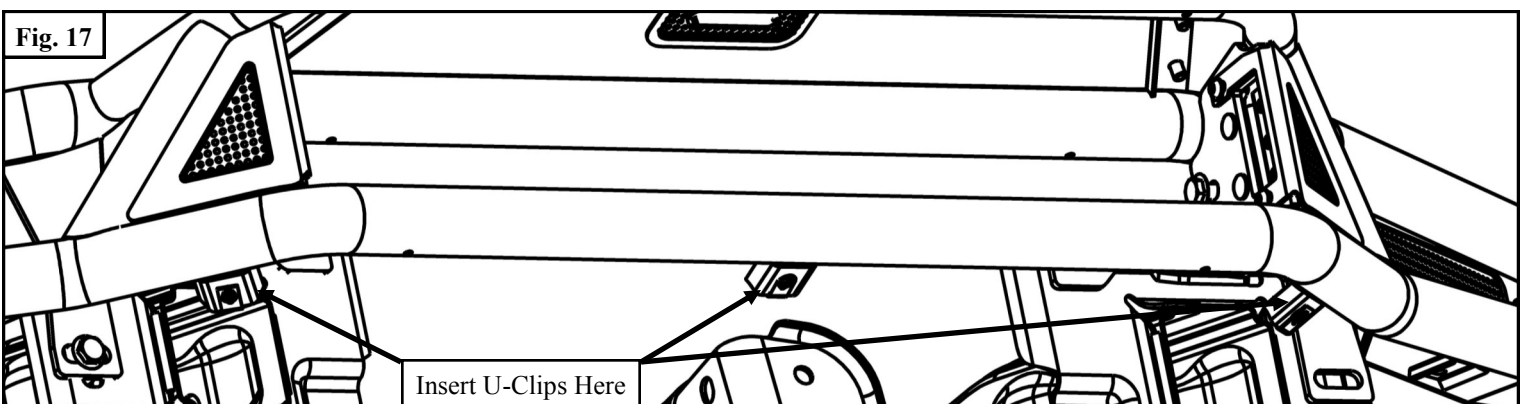
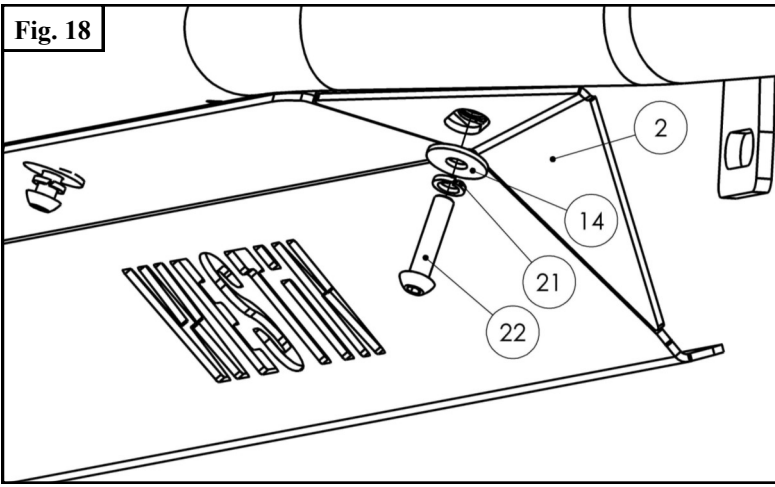
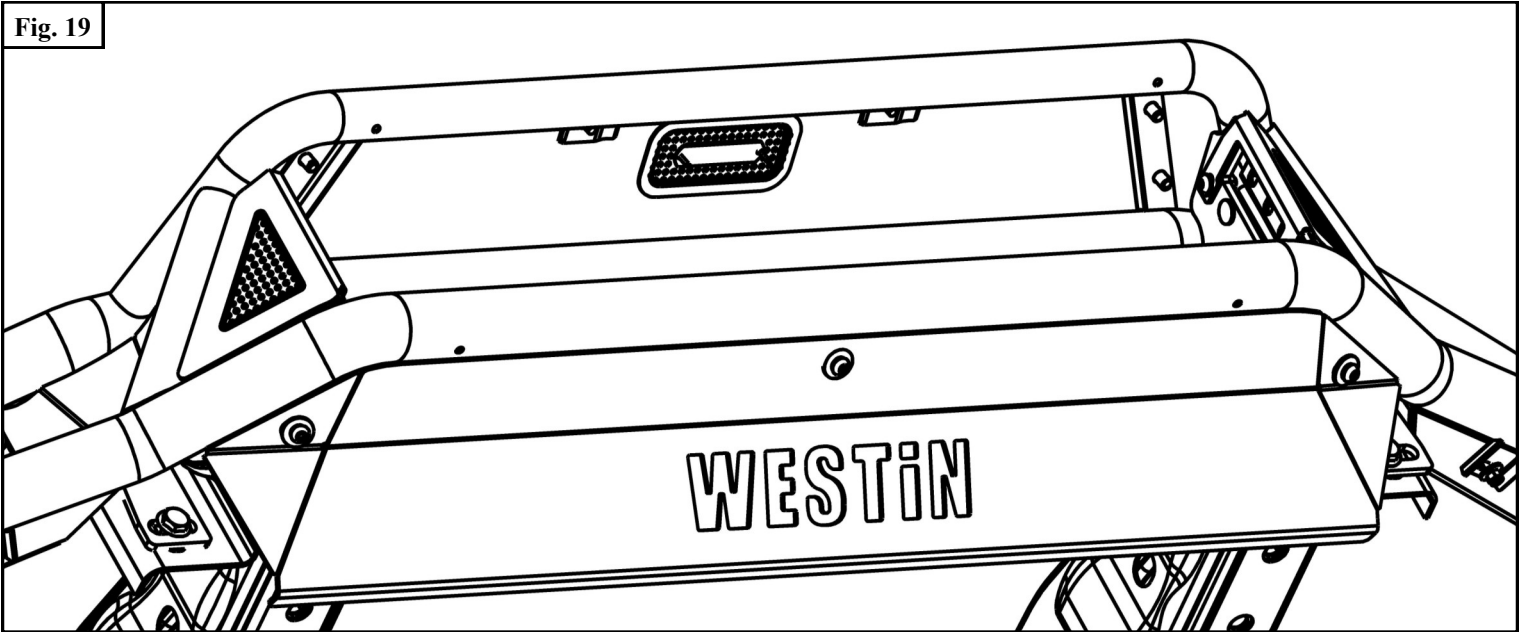

Fig. 18



16. Install upper skid plate (2) using items 14, 21, and 22.
See Figures 18 and 19.

Fig. 19



Westin Automotive Products, Inc.
320 W. Covina Blvd
San Dimas, Ca. 91773

Thank you for choosing Westin products
for additional installation assistance please call
Customer Service (800) 793-7846

www.westinautomotive.com

Installation Complete



WESTIN Westin Automotive Products, Inc.
320 W. Covina Blvd
San Dimas, Ca. 91773

P.N.: 75-586101-RevA

ECO #: W17-0028

7

Thank you for choosing Westin products
for additional installation assistance please call
Customer Service (800) 793-7846

www.westinautomotive.com

DATE: 9/12/17



WARNING



Failure to follow these instructions could lead to death, personal injury, and / or property damage.

FASTENERS:

All Westin supplied fasteners must be utilized and installed in accordance with the installation instructions and apply torque to the specifications as defined. **DOUBLE CHECK ALL FASTENERS BEFORE INITIAL USE, AND PERIODICALLY IN THE FUTURE TO ENSURE PROPER FUNCTION AND SAFETY.**

DRILLING:

Most Westin products do not require drilling for installation. If drilling is defined as required, use caution when drilling a vehicle. **FAILURE TO REVIEW AN AREA TO BE DRILLED MAY RESULT IN PERSONAL INJURY AND/OR INJURY TO OTHERS AS WELL AS VEHICLE DAMAGE.**

EYE PROTECTION:

ALWAYS WEAR SAFETY GLASSES OR GOGGLES DURING THE INSTALLATION PROCESS TO AVOID PERSONAL INJURY.

MAXIMUM TOWING/CARRYING CAPACITY:

The Westin Receiver Hitches will have a visible tow rating label affixed directly on the product. User should never exceed the vehicle manufacturers maximum tow and weight rating regardless of the capacity of the hitch. **FAILURE TO FOLLOW THESE GUIDELINES WILL VOID THE WESTIN WARRANTY AND MAY RESULT IN PERSONAL INJURY AND/OR INJURY TO OTHERS AS WELL AS VEHICLE DAMAGE.**



Westin Automotive Products, Inc.
320 W. Covina Blvd
San Dimas, Ca. 91773