

INSTALLATION GUIDE

AMP RESEARCH Power Step

MADE IN USA

APPLICATION
HUMMER® H2

MODEL YR
2003 - 2009

PART #
75107-01A

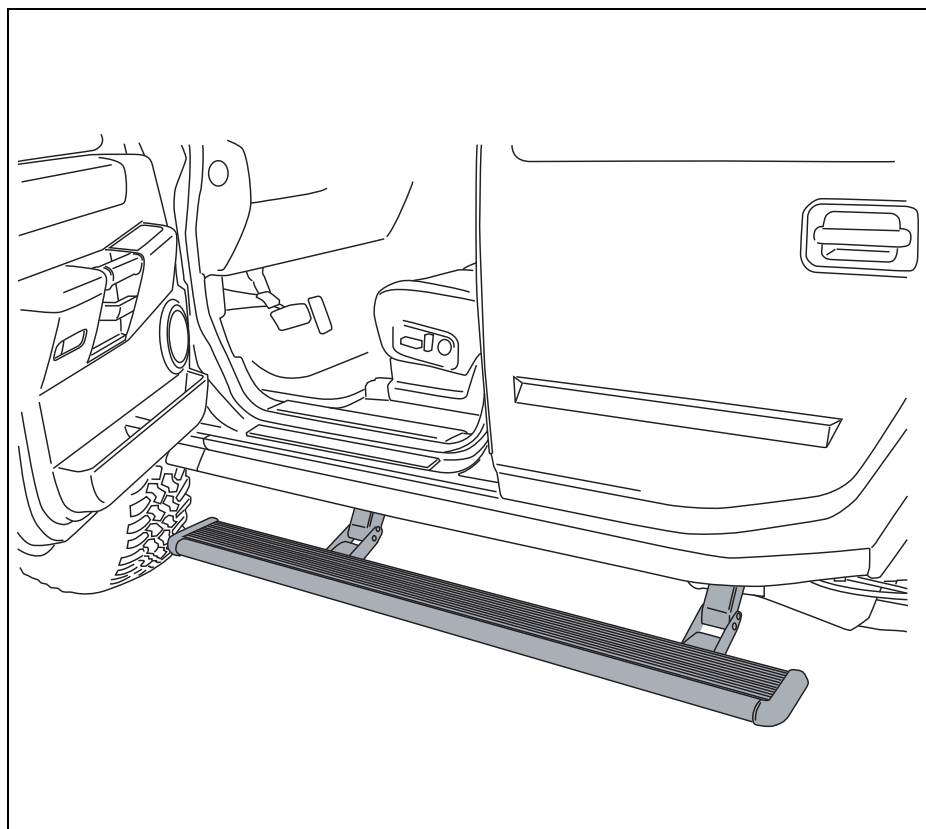

INSTALLATION TIME

3-5 Hours

Professional installation recommended

SKILL LEVEL



4= Experienced

TOOLS REQUIRED

- Safety goggles
- Measuring tape
- Flat blade screwdriver
- Phillips head screwdriver
- 9/32" drill bit
- 18 mm deep well socket with swivel / universal
- 17 mm socket
- 13 mm socket
- 10 mm socket
- Ratchet wrench and extension
- 13 mm end wrench
- Wire crimpers
- Wire stripper / cutter
- 3/16" hex key wrench (allen wrench)
- 4mm hex key wrench (allen wrench)
- Electrical tape
- Weather proof caulking (silicone-sealer)

WARRANTY

5-Year Limited Warranty

AMP RESEARCH TECH SUPPORT 1-888-983-2204 (Press 2) Monday - Friday, 6:00 AM - 5:00 PM PST

Invented, engineered and manufactured exclusively by AMP Research in the USA. May be covered by one of the following patents: 6,641,158; 6,830,257; 6,834,875; 6,938,909; 7,055,839; 7,380,807; 7,398,985; 7,584,975 ©2012 AMP Research. All rights reserved. Printed in USA.

INSTALLATION GUIDE

Attaching motor to linkage assembly

The motors must be attached to the linkage assemblies before continuing the installation process.

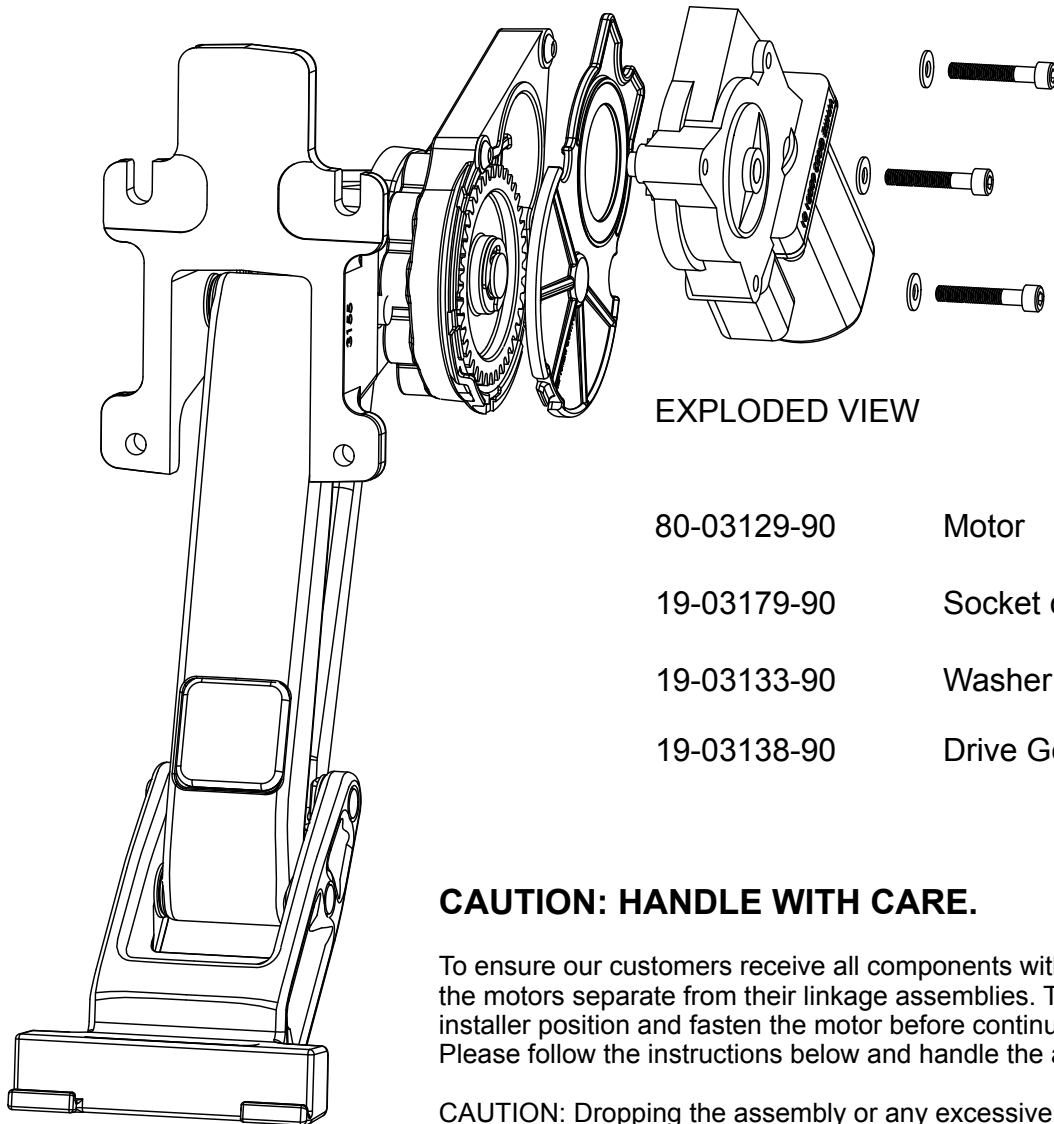

EXPLODED VIEW

80-03129-90	Motor
19-03179-90	Socket cap screw
19-03133-90	Washer
19-03138-90	Drive Gear Housing Cover

CAUTION: HANDLE WITH CARE.

To ensure our customers receive all components with full integrity, we pack the motors separate from their linkage assemblies. This requires that the installer position and fasten the motor before continuing with the install. Please follow the instructions below and handle the assembly carefully.

CAUTION: Dropping the assembly or any excessive impact MAY cause damage to the motor.

Instructions:

1. Position the gear cover in place as shown if not already in place.
2. Seat motor into position on the three mounting bosses. This may require an adjustment of the gear by moving the swing arms.
3. After seating into place, fasten the motor with the three motor mount screws with 4mm Hex Head. Tighten screws to 36 in-lbs (4N-m). **Do not over torque.**

Purpose: Due to vehicle-build variations the Power Step may not correctly align with vehicle cladding. Using supplied shims, please follow the instructions below to correct the alignment.

Misalignment:	Shim Correction:
The gap between board and vehicle cladding is too large toward rear of running board.	Shim rear mount at lower bolt. (diagram below)
The gap between board and vehicle cladding is too small toward rear of running board.	Shim rear mount at upper bolt. (diagram below)
The gap between board and vehicle cladding is too large toward front end of running board.	Shim front mount at lower bolt. (diagram below)
The gap between board and vehicle cladding is too small toward front end of running board.	Shim front mount at upper bolt. (diagram below)

Shim Placement: Place shim(s) *only where needed* as indicated above in “Misalignment/ Shim Correction” chart.

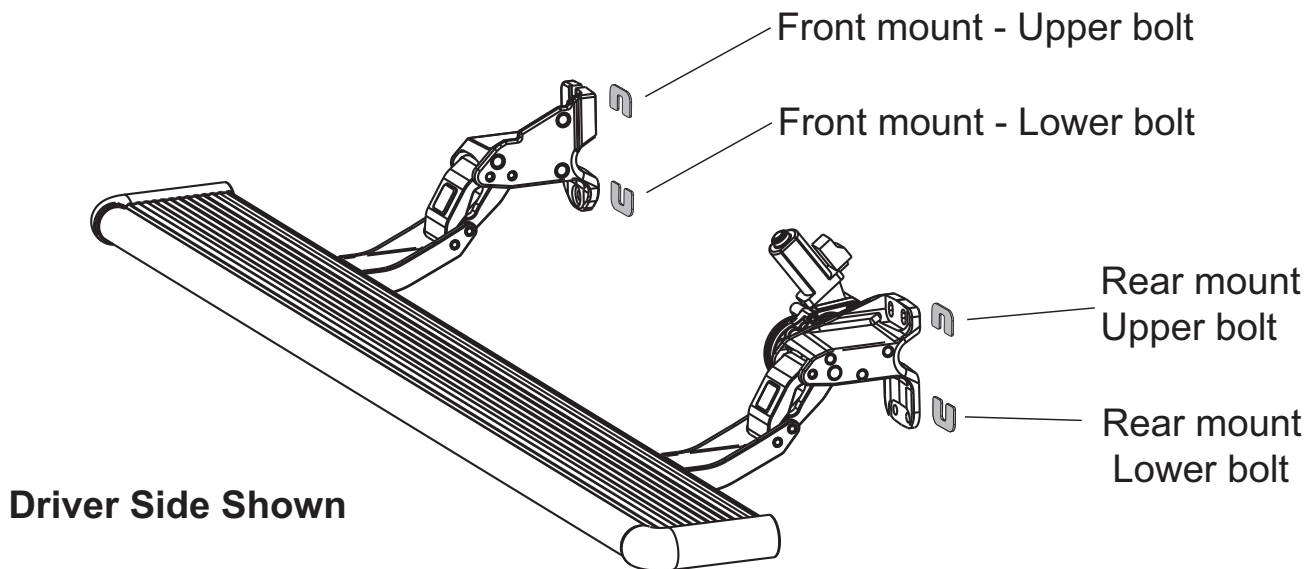

PARTS LIST AND HARDWARE IDENTIFICATION

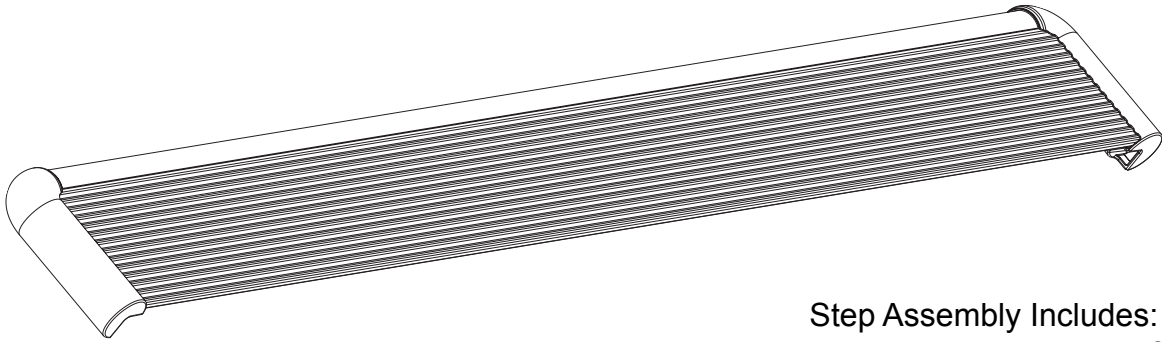

1 x2
80-02874-90
Running Board Assembly

Step Assembly Includes:
19-02869-11 Endcap Left (x1)
19-02869-12 Endcap Right (x1)
19-02663-90 T-Nut Insert (x2)
19-02822-90 Rivet (x2)

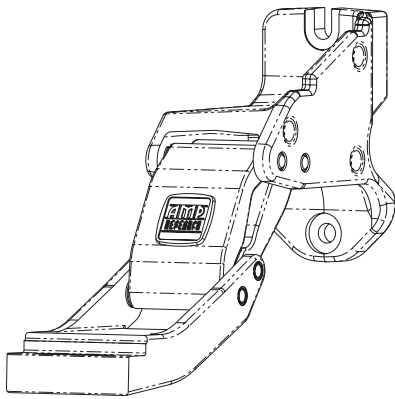

2 x2
10-02952-10
Idler Linkage

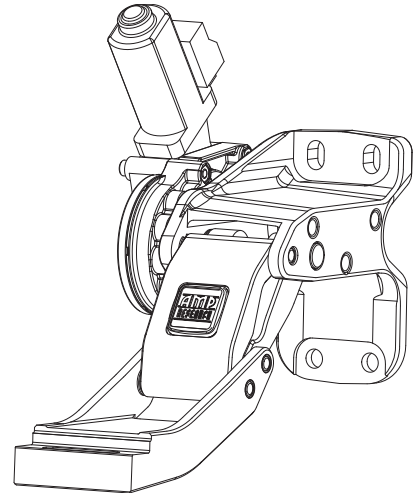

3 x2
10-03069-11
Motor Linkage

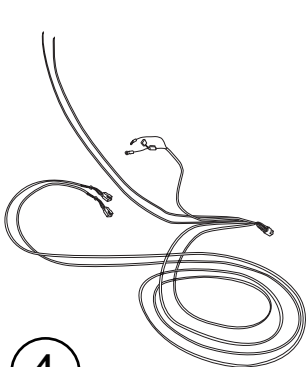

4
19-02947-91
Wire Harness

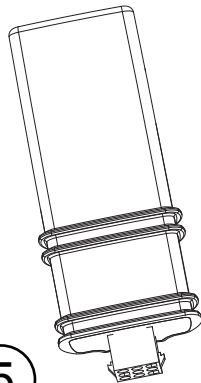

5
19-03297-A06
Controller

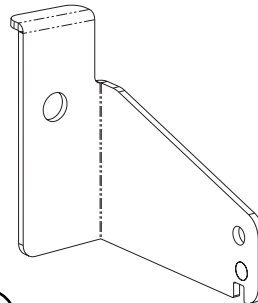

6
16-02946-90
Bracket

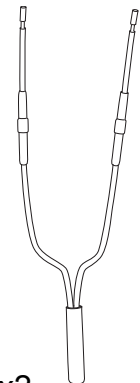

7 x2
19-02890-90
Double Diode

PARTS LIST AND
HARDWARE
IDENTIFICATION

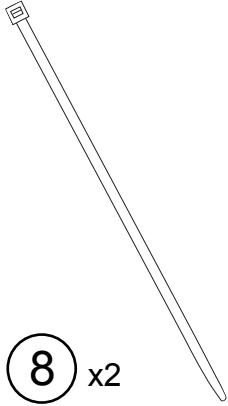

8 x2
19-03339-90
Cable Tie 11"

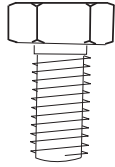

9
19-02849-90
Hex Bolt

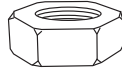

10
10-00115-60
Nylock Nut

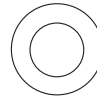

11
16-03014-90
Washer Black

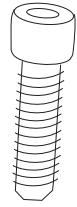

12 x8
19-02802-90
Socket Cap Screw



13 x25
19-02805-90
Cable Tie 7"

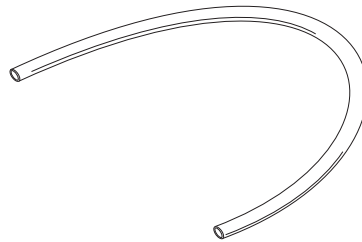

14
19-02992-90
Tubing (Installation Tool)

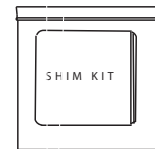

*REFER TO PAGE 3.
USE ONLY IF NEEDED.

15 Includes x4
19-03142-90
Shim



16 x2
19-02986-90
Connecting Wire

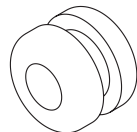

17
19-02640-90
Grommet



18 x2
19-02989-90
Butt Connector

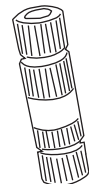

19 x4
19-03354-90
Posi-Tap™ (Red/Grey)

Remove canister purge valve bracket from rock rail
remove existing rock rail
by unscrewing ten bolts

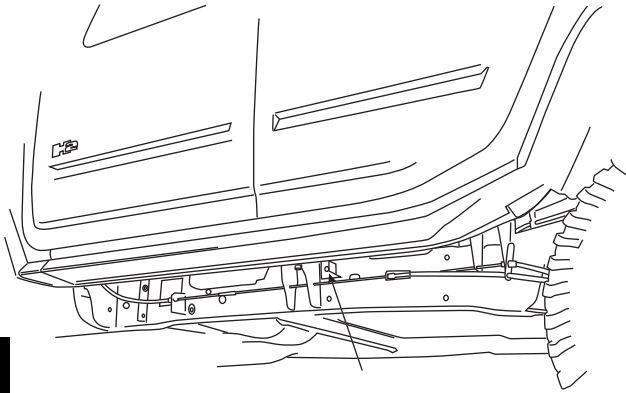

1

Install new canister purge valve bracket on fourth set of holes from the front (upper bolt)

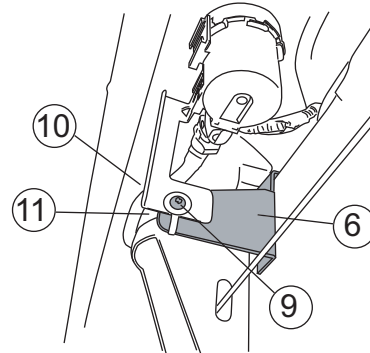

(Attach canister purge valve to bracket)

2

Mount front linkage assembly with existing bolts on the second set of holes from the front
With 18mm socket

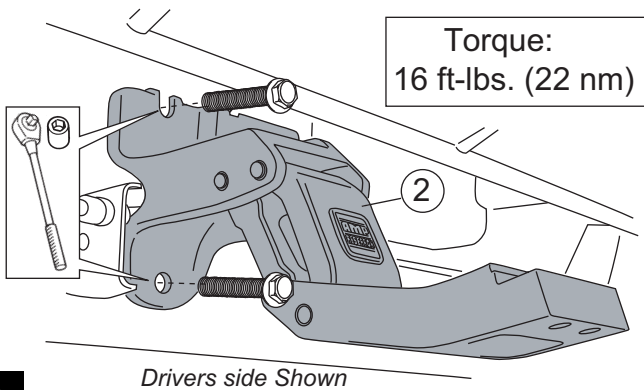

3

Mount motorized linkage with existing bolts on the fifth set of holes from the front. Use rearward hole set on linkage.

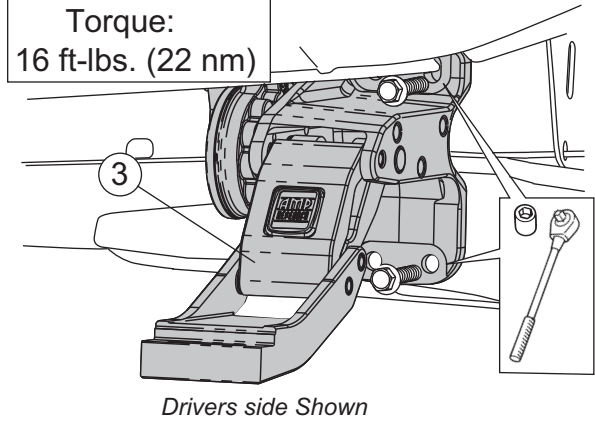

4

To mount running board, slide t-nut into position
(Align with holes)

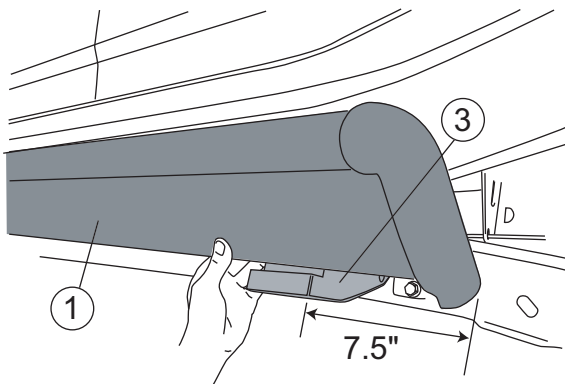

5

Tighten 4 screws with 3/16" allen wrench

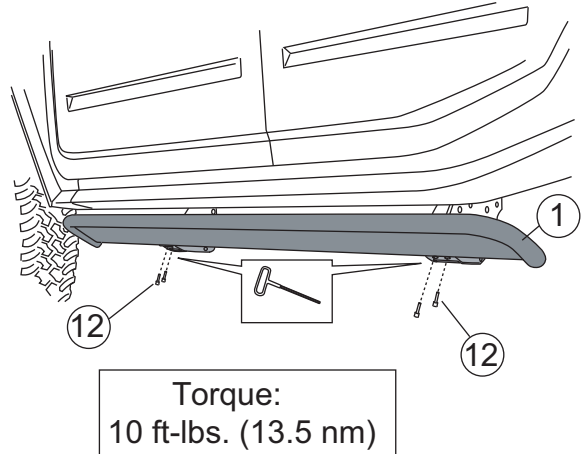

6

Using the two 11" cable ties, mount controller to factory wire conduit above brake booster on drivers side of truck.

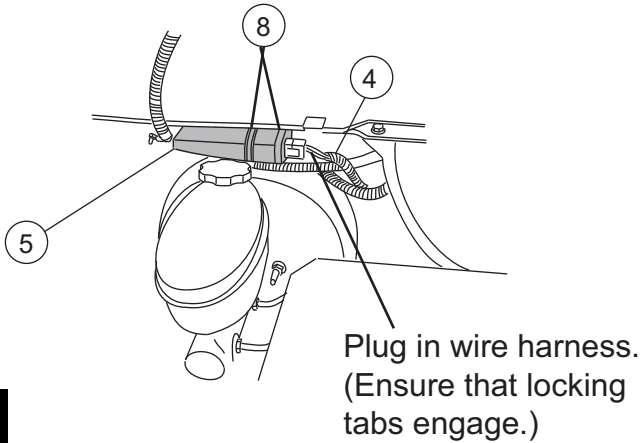

7

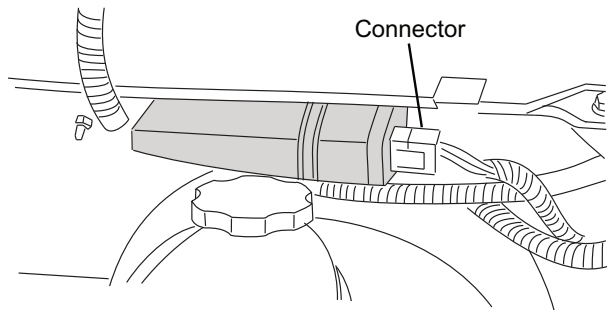

Note: Check to make sure all metal terminals are fully seated in connector (locked into place) before connecting. Ensure also that locking tabs on connector engage after mating the two connectors.

8

Remove power fuse. Attach power lead (RED) wire to positive lead in the junction Box. Attach ground lead (BLACK) to junction box mounting bracket bolt.

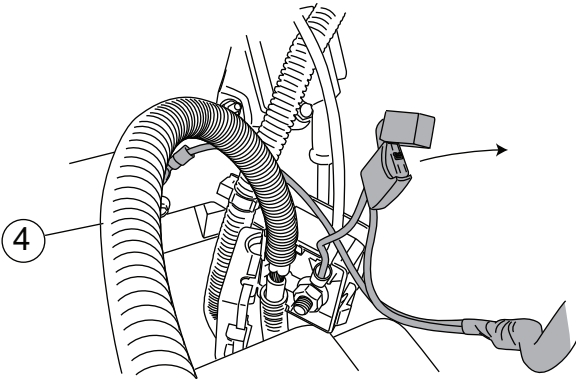

9

Route long end of wire harness across engine and down through passenger side wheel well. Route short end down driver side wheel well.

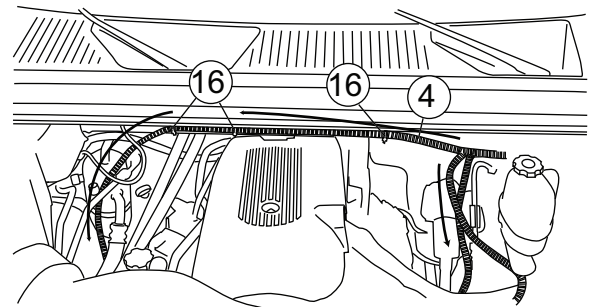

10

Route the wire harness along the frame using nylon zip ties.

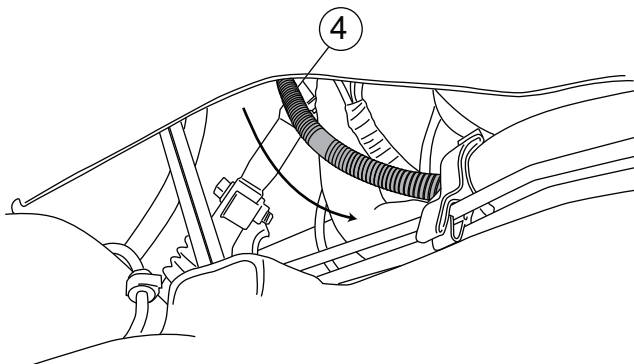

11

Poke hole through rubber grommet near front door on underside of floor panel with phillips screwdriver. Push wire through hole.

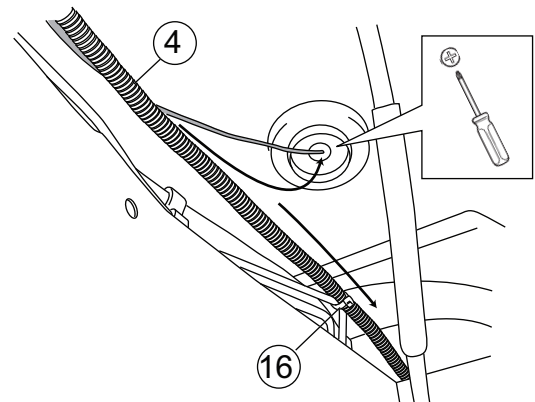

12

Pop off the threshold cover with screw driver and remove the kick panel.

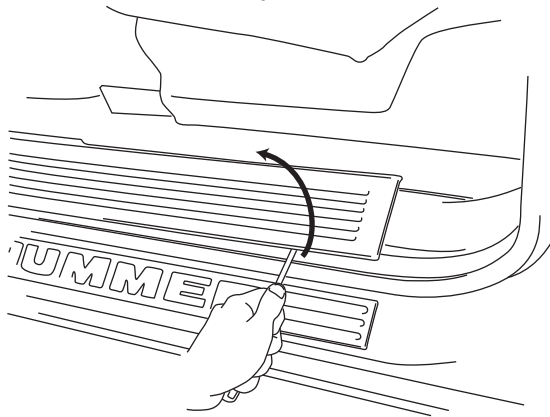

13

Pull up the carpet and thread purple wire through the floor panel (same steps on passenger side except drill through metal grommet with 9/32" bit).

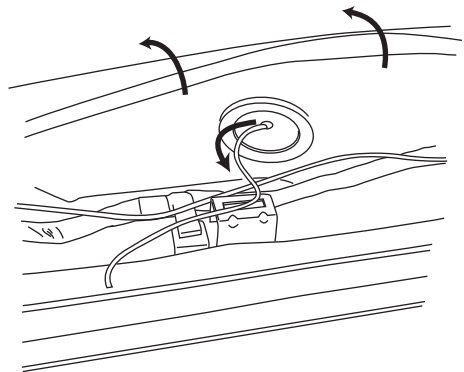

14

Seal wire and grommet with silicone sealer. Cover with tape to prevent sticking to carpet.

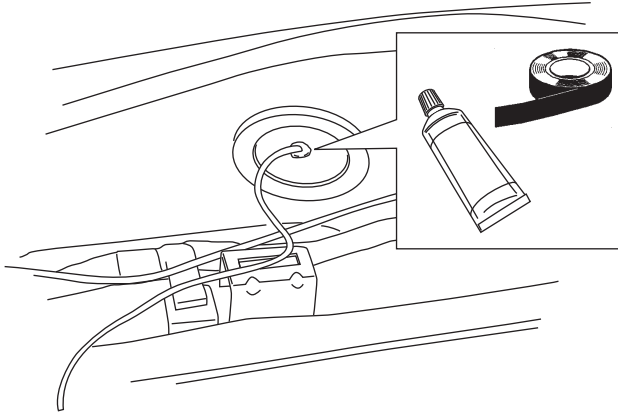

15

Carefully remove wire wrap and find rear door ajar wire (Driver side: Light Blue with Black Stripe; Passenger side: Green with Black Stripe). Note: Passenger side wire will be found rear of the "T" junction where wires cross under front seat.

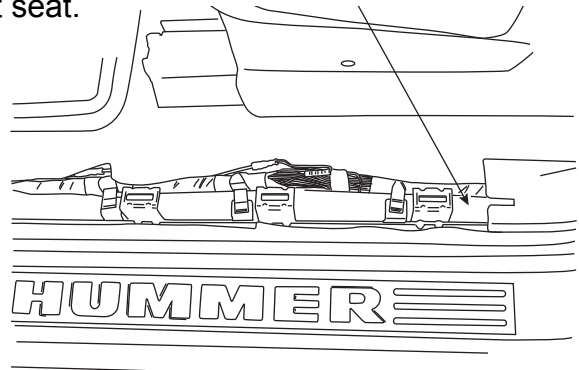

16

Attach trigger wire of Step 15 to a Double Diode Harness. Using supplied Posi-Tap, splice one leg of Double Diode Harness into rear door ajar wire found in Step 16.

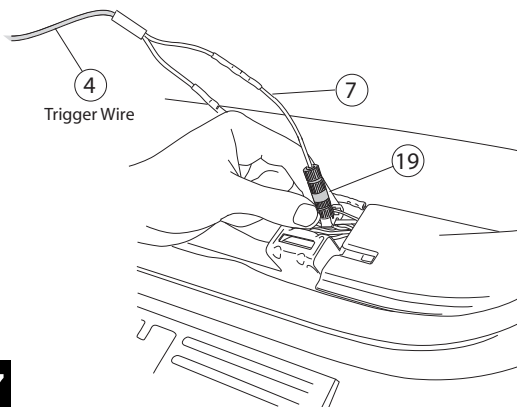

17

The following steps are model year specific. Verify the vehicle model year and follow only the appropriate steps.

2003 - 2007 Skip to step 22

**2008 - 2008 see steps 19 - 21
Skip steps 22-26 & 32**

18

To remove door panel, first pry back tab on door lock to remove then pry off plastic covers by handle and door latch. Remove the 3 door bolts and then remove door panel by prying loose all panel fasteners.

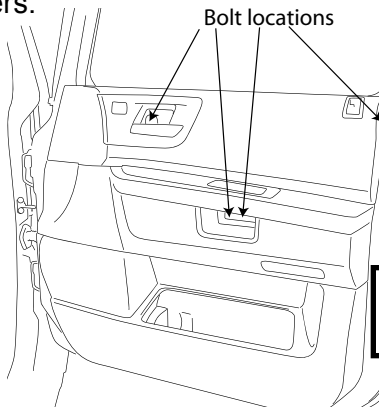

Model Year
08-09 Only

19

Remove door latch cable from door panel

Model Year
08-09 Only

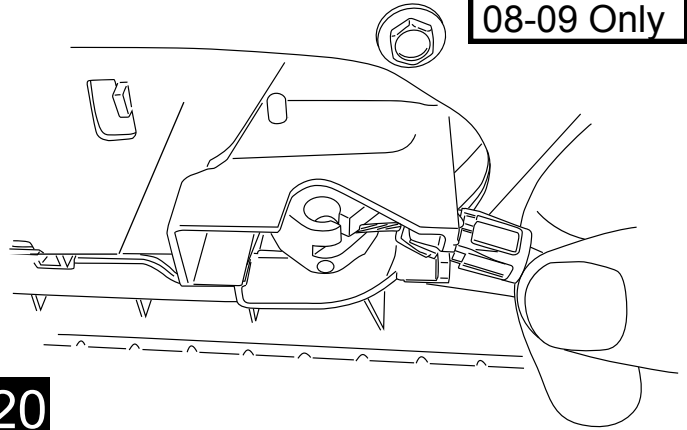

20

See steps 27-31 to run wires through door panel to brown connector on switch panel. Driver side: connect trigger wire to Grey/Black. Passenger side connect trigger wire to Tan/White.

Model Year
08-09 Only

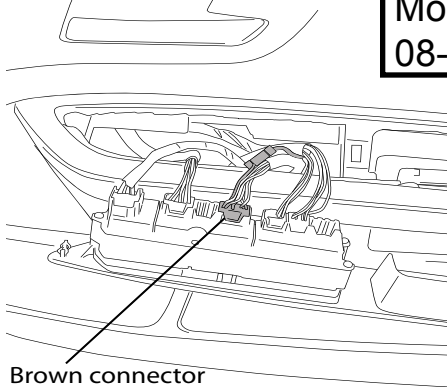

21

To remove door panel, first remove lock mechanism.

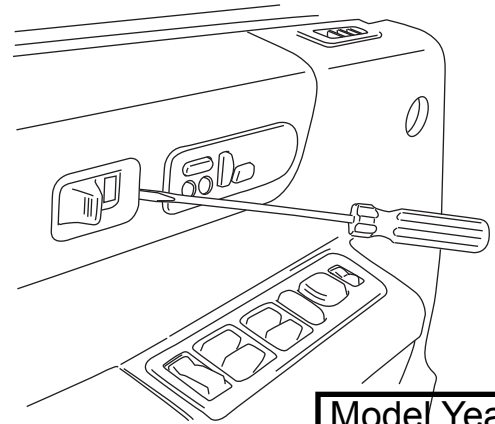

Model Year
2003 - 2007

22

Remove door handle.

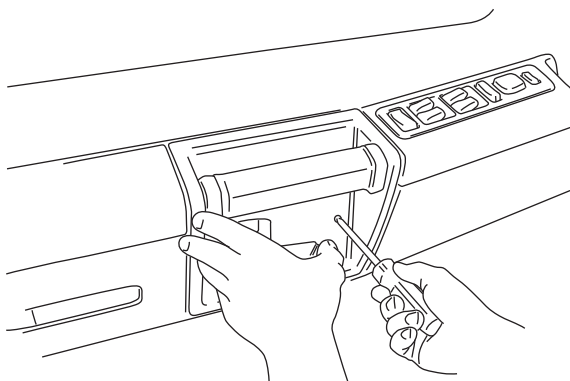

Model Year
2003 - 2007

23

Remove switch plate and unplug.

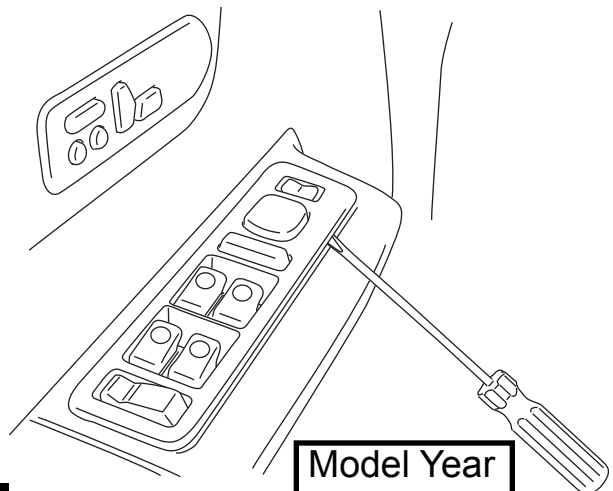

Model Year
2003 - 2007

24

Pry loose door panel.

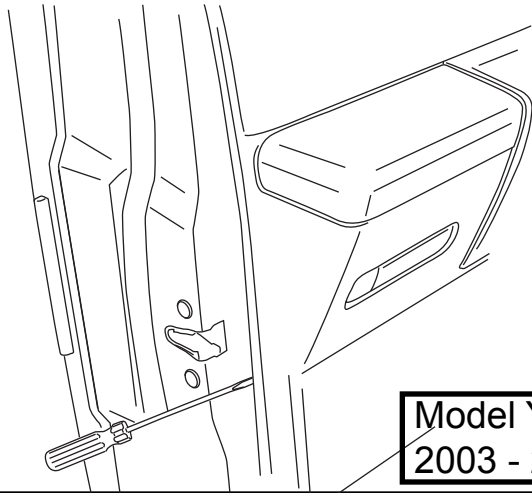

25

Model Year
2003 - 2007

Unplug door light and remove door panel.

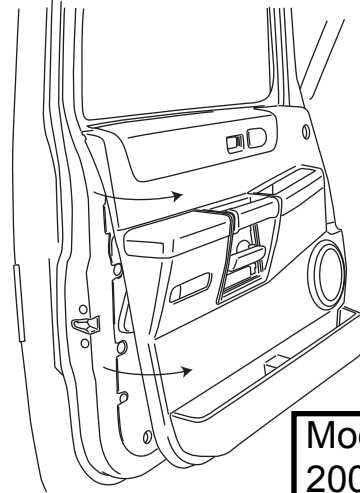

26

Model Year
2003 - 2007

Pull back the door weather guard.
Pry off speaker and unplug.

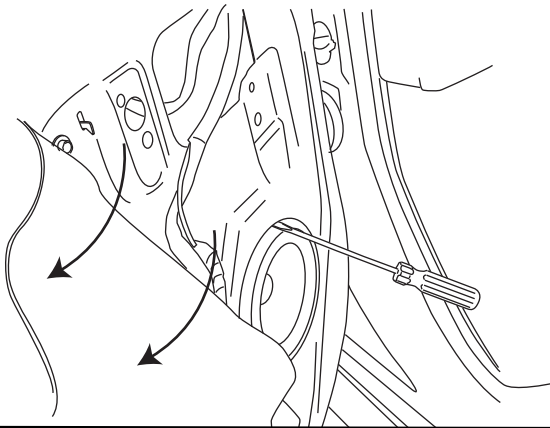

27

Thread plastic tube through accordeon.

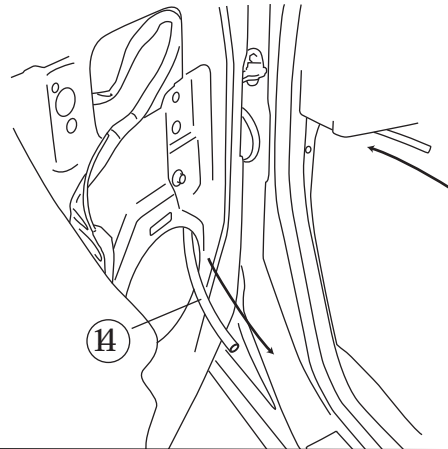

28

Feed plastic tubing through door wiring and into door. Thread supplied connecting wire through tubing.

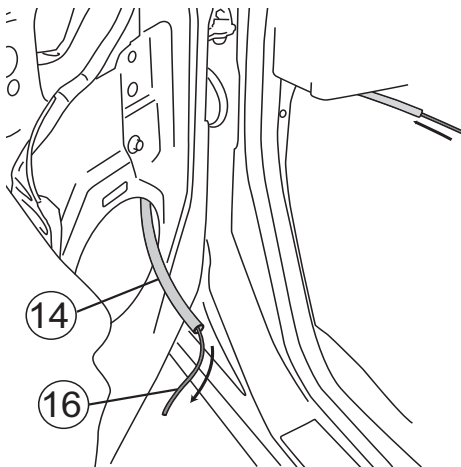

29

Remove plastic tubing, leaving connecting wire in place.

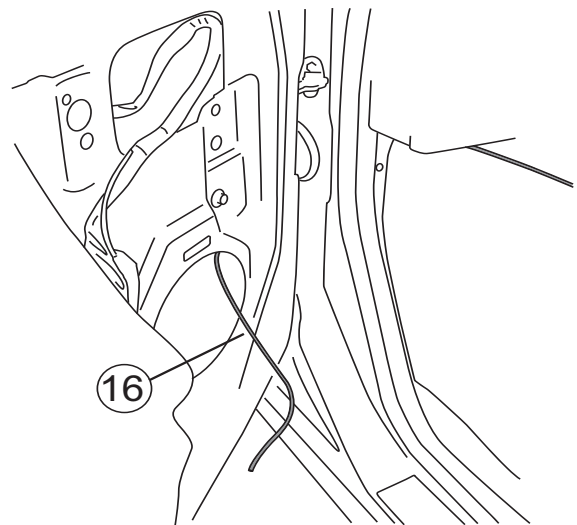

30

Route wire along harness going to switch plate.

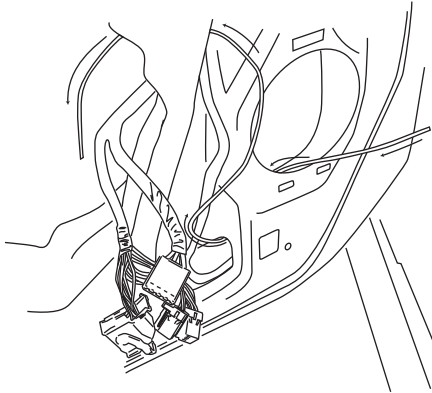

31

Using supplied Posi-Taps™, splice into front door ajar wire (Driver side: Grey with black stripe; Passenger side: Black with white stripe).

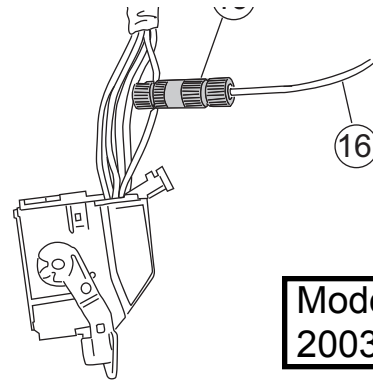

Model Year
2003 - 2007

32

Secure wire harness with black tape.

Caution: Unsecure wire may interfere with window operation.

Push weather guard back into place.

Reconnect speaker wire and replace speaker.

Reinstall door panel.

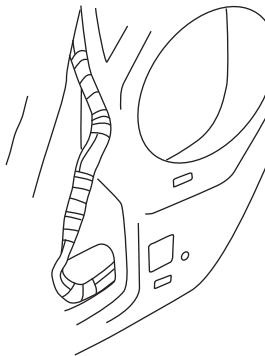

33

Route connecting wire back along factory wire bundle under sill plate toward the double diode harness that was installed in Step 17.

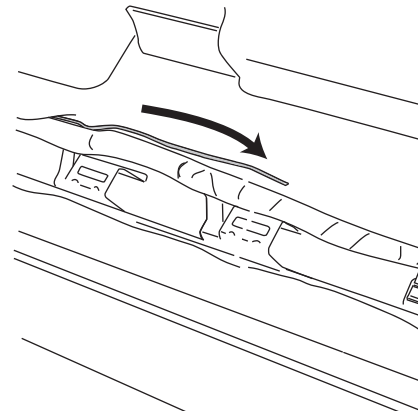

34

Using supplied red butt connector, attach connecting wire to the remaining open leg of double diode harness. Secure all loose wires with tie wraps and/or electrical tape.

Recommendation: Wait to close up sill and door panel until you verify that the Power Step is wired and operating correctly.

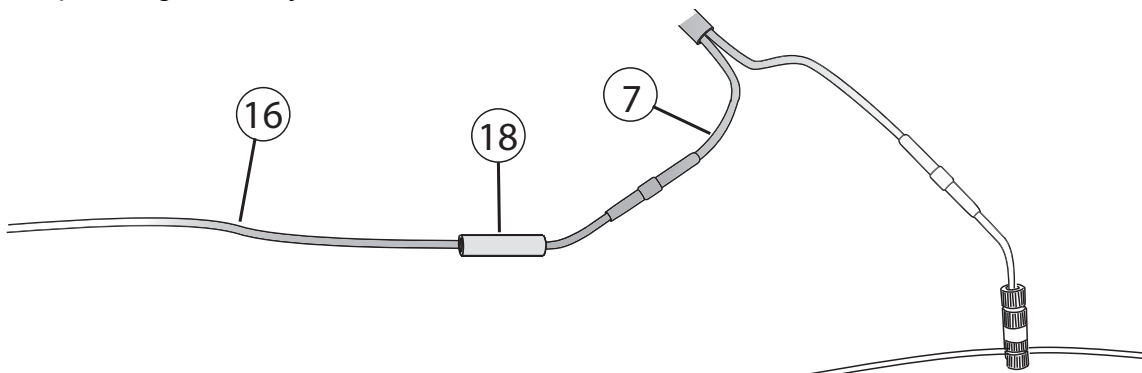

35

Plug wire harness into motor.

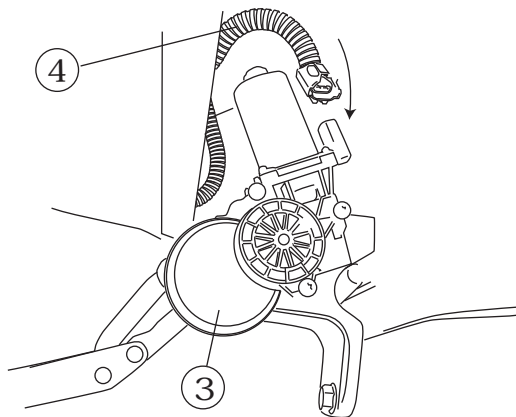

Replace power fuse.

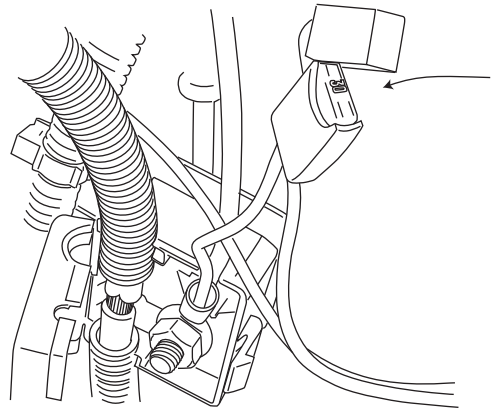

35

36

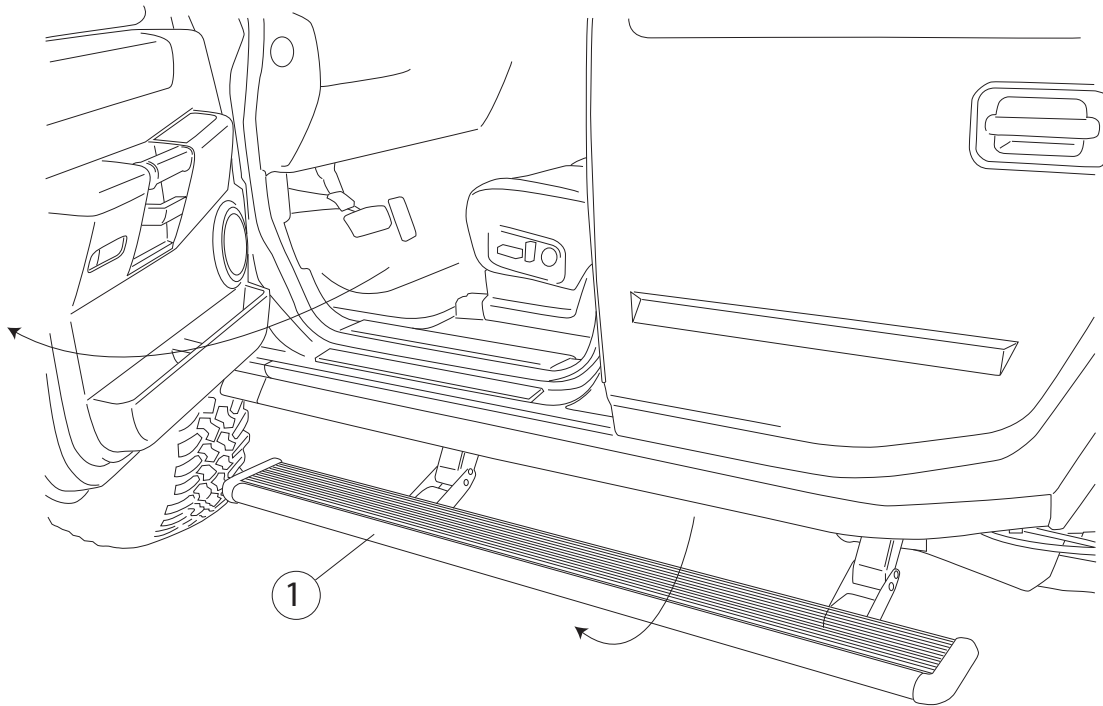

FINAL SYSTEM CHECK

Check that all doors activate the PowerStep and the LED lights work when doors open and close.

NORMAL OPERATION: When the doors open, PowerStep automatically deploys from under the vehicle.

When the doors are closed, PowerStep will automatically return to the stowed/retracted position. **Note that there is a 2-second delay before the PowerStep returns to the stowed/retracted position.**

CORRECT OPERATION OF LIGHTS: All four lamps will illuminate upon opening any door of vehicle. Lamps will stay on until restowing of both Power Steps or until 5 minutes has expired with the doors open. When the lights timeout after 5 minutes, they can be reilluminated by closing and opening any door of vehicle.

37

POWER-DEPLOYABLE RUNNING BOARDS OPERATION: AMP Research PowerStep running boards automatically move when the doors are opened to assist entering and exiting the vehicle.



Automatic power deploy:

The running boards will extend down and out when the doors are opened.

Automatic power stow:

The running boards will return to the stowed position when the doors are closed. There will be a 2-second delay before the running boards move to the stowed position.

Automatic stop:

If an object is in the way of the moving running board, the running board will automatically stop. To reset, clear any obstruction, then simply open and close the door to resume normal operation.



Manually set in the deployed (OUT) position for access to the roof:

The running boards can be manually set in the deployed position by firmly holding the step down with your foot while at the same time closing the door. To resume normal operation, open and close the door.

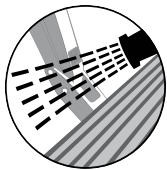

Maintenance: In adverse conditions, debris such as mud, dirt, and salt may become trapped in the running board mechanism, possibly leading to unwanted noise. If this occurs, manually set the running boards to the deployed position and flush the front and rear hinge arms with a high-pressure car wash wand. Avoid spraying the motors directly. After washing, apply silicone spray lubricant to the hinge pivot pins. Do not apply silicone, wax or protectants like Armor All® to the running board stepping surface.

Caution! Keep hands away when the running board is in motion.

5-YEAR LIMITED WARRANTY

AMP RESEARCH warrants this product to be free from defects in material and workmanship for FIVE (5) YEARS FROM DATE OF PURCHASE, provided there has been normal use and proper maintenance. This warranty applies to the original purchaser only. All remedies under this warranty are limited to the repair replacement of the product itself, or the repair or replacement of any component part thereof, found by the factory to be defective within the time period specified. The decision to repair or replace is wholly within the discretion of the manufacturer.

This warranty specifically excludes labor. If you have a warranty claim, first you must call our factory at the number below for instructions. You must retain proof of purchase and submit a copy with any items returned for warranty work. Upon completion of warranty work, if any, we will return the repaired or replaced item or items to you freight prepaid. Damage to our products caused by accidents, fire, vandalism, negligence, misinstallation, misuse, Acts of God, or by defective parts not manufactured by us, is not covered under this warranty.

ANY IMPLIED WARRANTIES OF MERCHANTABILITY AND/OR FITNESS FOR A PARTICULAR PURPOSE CREATED HEREBY ARE LIMITED IN DURATION TO THE SAME DURATION AND SCOPE AS THE EXPRESS WRITTEN WARRANTY. OUR COMPANY SHALL NOT BE LIABLE FOR ANY INCIDENTAL OR CONSEQUENTIAL DAMAGE.

Some states do not allow limitations on how long an implied warranty lasts, or the exclusion or limitation of incidental or consequential damages, so the above limitations or exclusions may not apply to you. This warranty gives you specific legal rights, and you may also have other rights that vary from state to state.

FOR WARRANTY ISSUES WITH THIS PRODUCT PLEASE CALL AMP RESEARCH CUSTOMER SERVICE 1-888-983-2204

WARNING

Be sure to read and precisely follow the provided instructions when installing this product. Failure to do so could place the vehicle occupants in a potentially dangerous situation. After installing or reinstalling, re-check to insure that the product is properly installed.