

Brackets must be configured for Passenger or Driver-Side as shown.

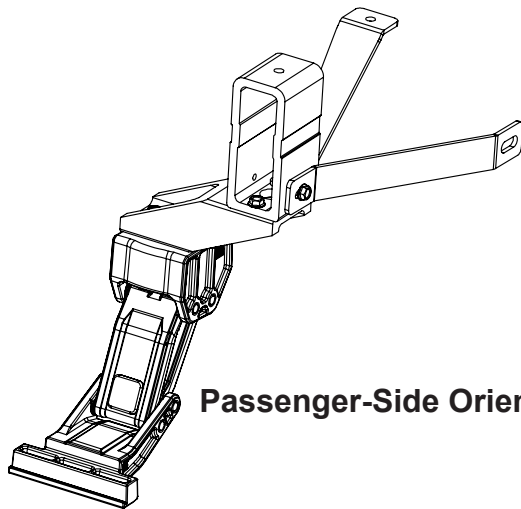

Passenger-Side Orientation

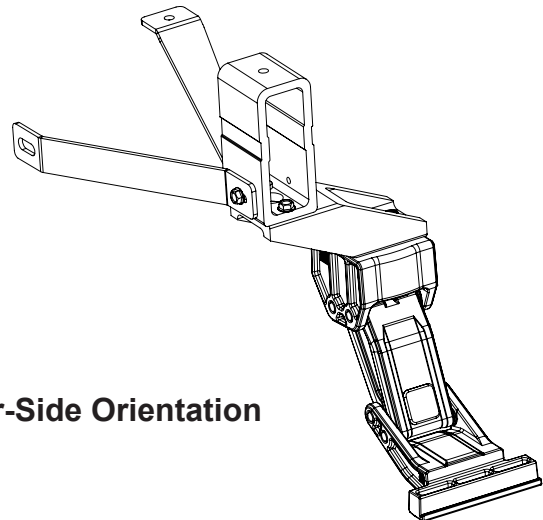

Driver-Side Orientation

1

Using a 15mm Socket assemble Lateral mount onto Linkage assembly. Torque bolts to 20 ft-lbs. Note: Drivers side shown. Mirror for passenger side (See image in step 1 for passenger orientation).

Using a 13mm Socket assemble Frame mount onto Lateral mount. Do not tighten bolts yet.

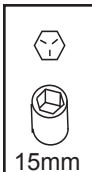
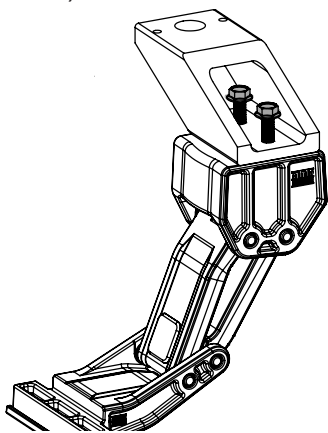

3

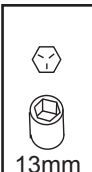
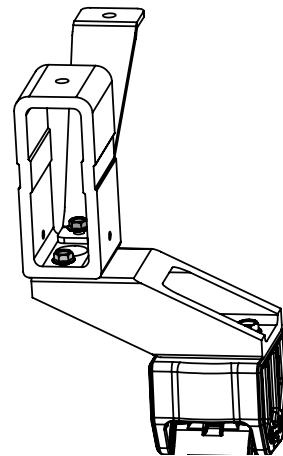

AMP RESEARCH TECH SUPPORT 1-888-983-2204 (Press 2) Monday - Friday, 6:00 AM - 5:00 PM PST

BedStep2™ is invented, designed, engineered and manufactured exclusively by AMP Research and may be covered by one of the following patents: 6,641,158; 6,830,257; 6,938,909; 7,055,839; 7,380,807; 7,398,985; 7,584,975. Made in USA © 2011 AMP Research
Three-year limited warranty. Professional installation is recommended.

Locate forward most bed channel. Insert Threaded Plate into Bed Channel. Jog in bracket must match jog in Bed Channel. (Driver Side Shown)

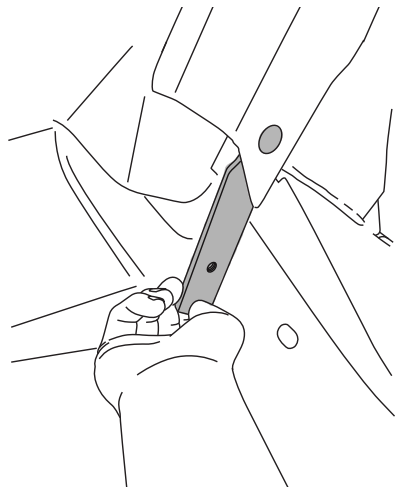

4

Using a 15mm socket with extension, align bolt with threaded plate. Do not tighten.

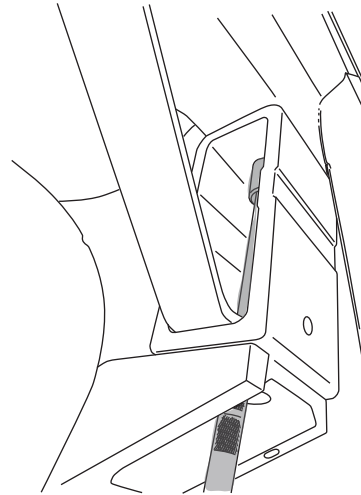

5

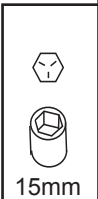

Locate the step pad on the center position of the lower linkage assembly and secure using provided PT Screws. Tighten to 5 ft-lbs using T25 Torx bit. Align Step pad to be in line with fender.

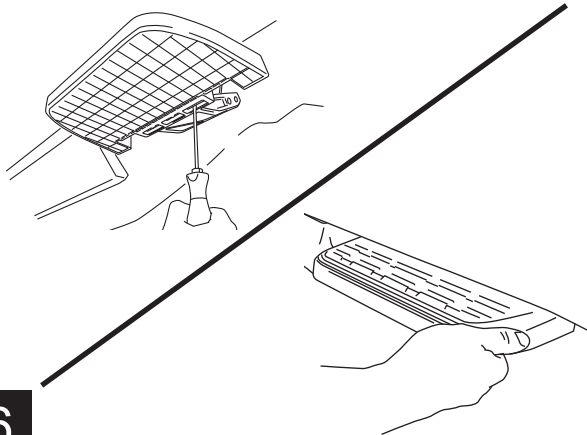

6

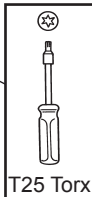

Using a 15mm socket with extension, align bolt with threaded plate. Torque to 20 ft-lbs.

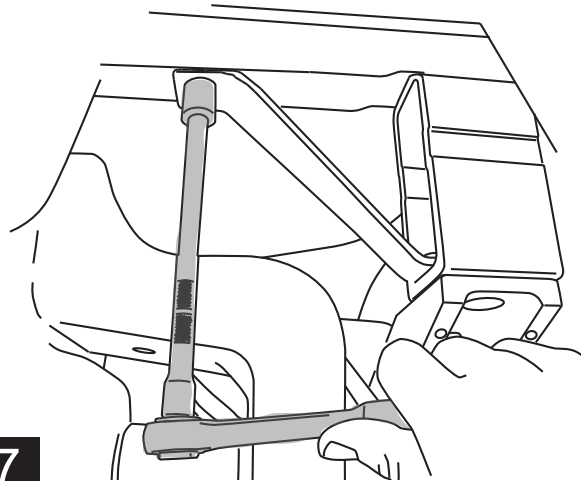

7

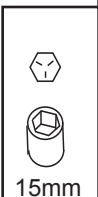

Torque bolts from Steps 3 and 5 to 20 ft-lbs.

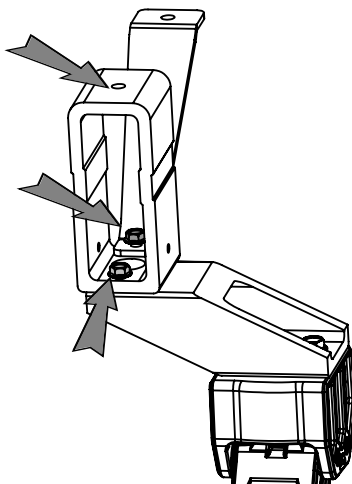

8

For 2011 - up Short bed models: Using a 15mm socket remove four bolts holding factory bracket in place. The two rear most U clips will need to be removed in step 10. **For all other models skip to step 10.**

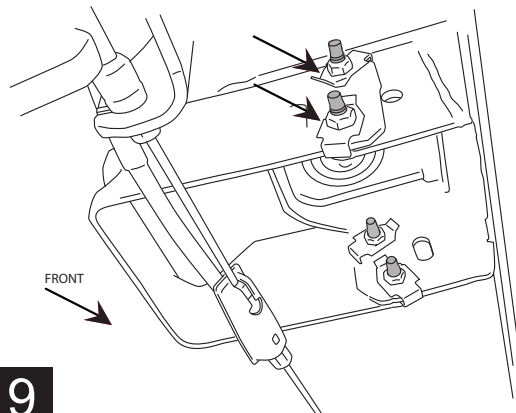

9

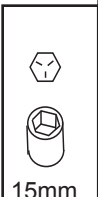

For 2011 - up Short bed models: Remove the two rearmost u clips off the bracket and change orientation of the bolt so that the bolt head is on the outside of the bracket. Torque bolts to 16 ft-lbs.

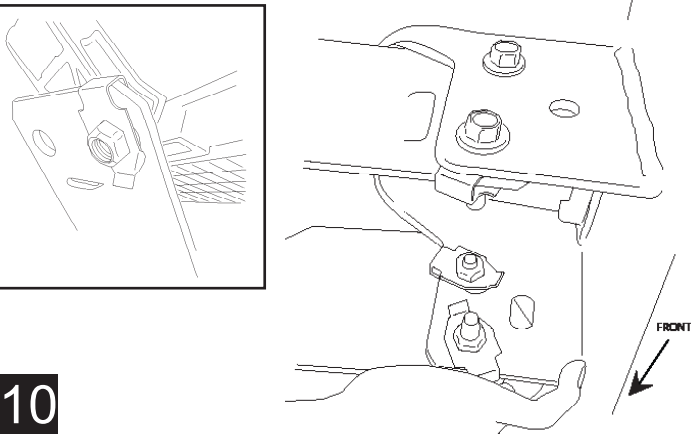

10

For 2011 - up Short bed models: Attach bracket to threaded hole in frame mount. Rotate bracket up to position and use provided M12 Hardware. Tighten M8 bolt to 16 ft-lbs and M12 bolt to 35 ft-lbs.

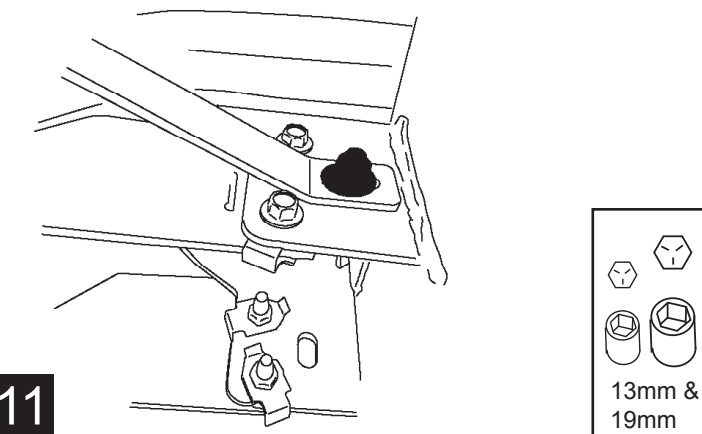

11

For all other Models : Attach bracket to threaded hole in frame mount. Rotate bracket into position and use the provided M12 hardware.

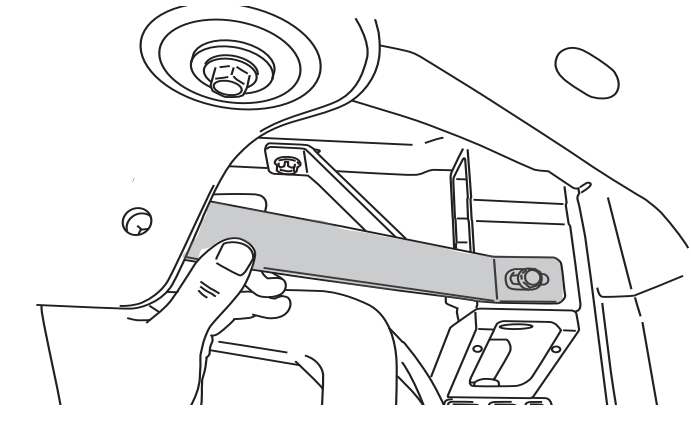

NOTE: If a hole is not provided on a factory body mount, a hole must be drilled using a 1/2" drill bit.

12

For all other Models: Using 19mm socket, tighten bolt to 35 ft-lbs. Tighten M8 screw from step 9 to 16 ft-lbs.

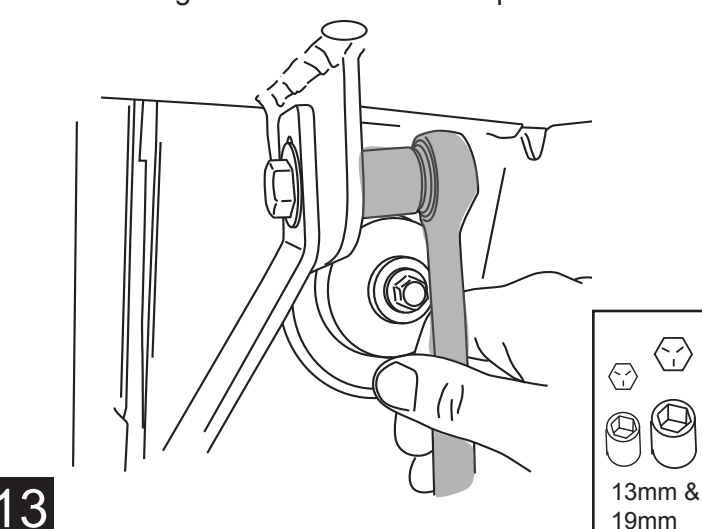

13

To deploy the step, press down using your foot on the outside edge of the step pad.

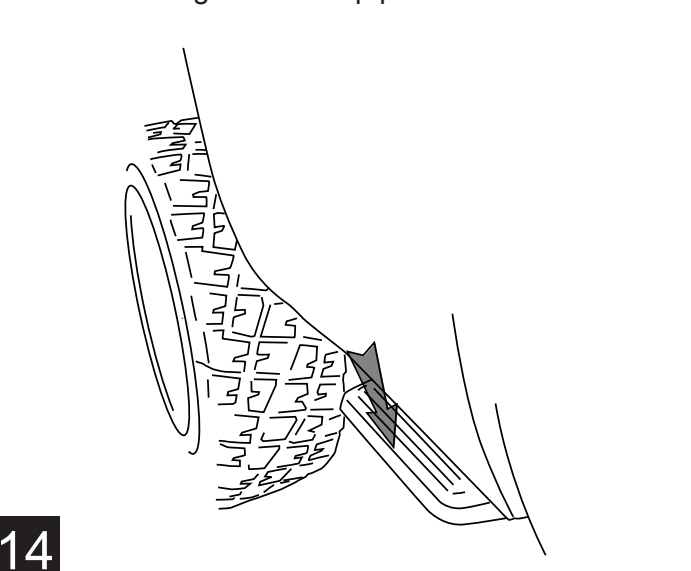

14

To retract, gently kick up on the underside of the step pad.

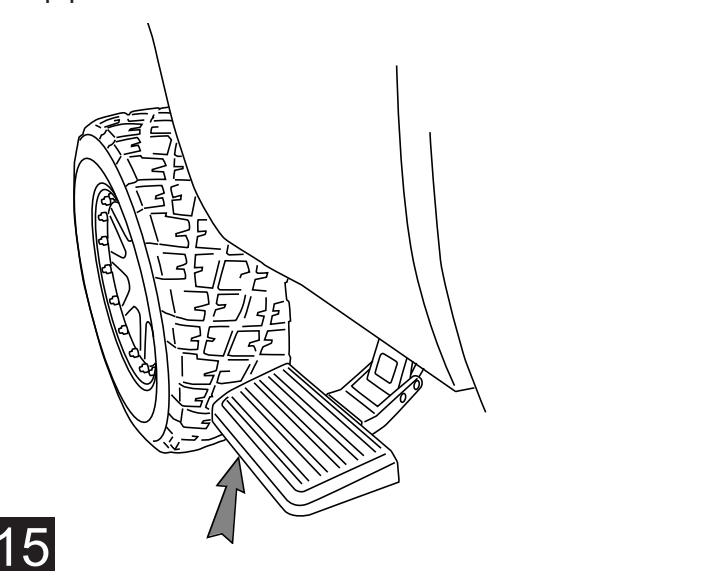

15



Congratulations on your purchase of the genuine AMP Research BedStep2™. Here's what you should know...

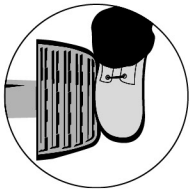

BEDSTEP2™ OPERATION

The AMP Research BedStep2™ is foot operated and deploys and retracts with a nudge of your foot. To deploy, press down using your foot, on the outside edge of the step pad.

Maximum load capacity of the deployed step pad is 300 lbs.

Always use appropriate hand holds when stepping up to or down from your truck's cargo bed.

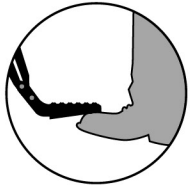

To retract, gently kick up on the underside of the step pad.

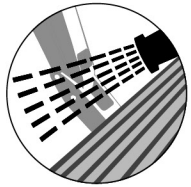

MAINTENANCE TIPS - The stepping surface and linkage should be periodically washed with mild soap and water using a soft brush or sponge to dislodge any mud, dirt or accumulated road grime.

In severe driving conditions, pressure washing the linkage is strongly recommended.

Do not apply silicone spray, waxes or protectants like Armor All® to the stepping surfaces.

CAUTION! BEDSTEP2™ SHOULD ALWAYS BE STOWED IN THE RETRACTED POSITION WHEN DRIVING.

AMP RESEARCH LIMITED WARRANTY

AMP RESEARCH warrants this product to be free from defects in material and workmanship for THREE (3) YEARS FROM DATE OF PURCHASE, provided there has been normal use and proper maintenance. This warranty applies to the original purchaser only. All remedies under this warranty are limited to the repair replacement of the product itself, or the repair or replacement of any component part thereof, found by the factory to be defective within the time period specified. The decision to repair or replace is wholly within the discretion of the manufacturer.

This warranty specifically excludes labor. If you have a warranty claim, first you must call our factory at the number below for instructions. You must retain proof of purchase and submit a copy with any items returned for warranty work. Upon completion of warranty work, if any, we will return the repaired or replaced item or items to you freight prepaid. Damage to our products caused by accidents, fire, vandalism, negligence, misinstallation, misuse, Acts of God, or by defective parts not manufactured by us, is not covered under this warranty.

ANY IMPLIED WARRANTIES OF MERCHANTABILITY AND/OR FITNESS FOR A PARTICULAR PURPOSE CREATED HEREBY ARE LIMITED IN DURATION TO THE SAME DURATION AND SCOPE AS THE EXPRESS WRITTEN WARRANTY. OUR COMPANY SHALL NOT BE LIABLE FOR ANY INCIDENTAL OR CONSEQUENTIAL DAMAGE.

Some states do not allow limitations on how long an implied warranty lasts, or the exclusion or limitation of incidental or consequential damages, so the above limitations or exclusions may not apply to you. This warranty gives you specific legal rights, and you may also have other rights that vary from state to state.

FOR WARRANTY ISSUES WITH THIS PRODUCT PLEASE CALL AMP RESEARCH CUSTOMER SERVICE 1-888-983-2204

WARNING

Be sure to read and precisely follow the provided instructions when installing this product. Failure to do so could place the vehicle occupants in a potentially dangerous situation. After installing or reinstalling, re-check to insure that the product is properly installed.