

INSTALLATION GUIDE

AMP RESEARCH Power Step

MADE IN USA

APPLICATION

AMP Part

Chevrolet Silverado/ GMC Sierra - Crew Cab 2015

76147-01A (Diesel Only)

Chevrolet Silverado/ GMC Sierra - Double Cab 2015*

76147-01A (Diesel Only)

*Modification required to running board assembly. See Item 1 on page 3.

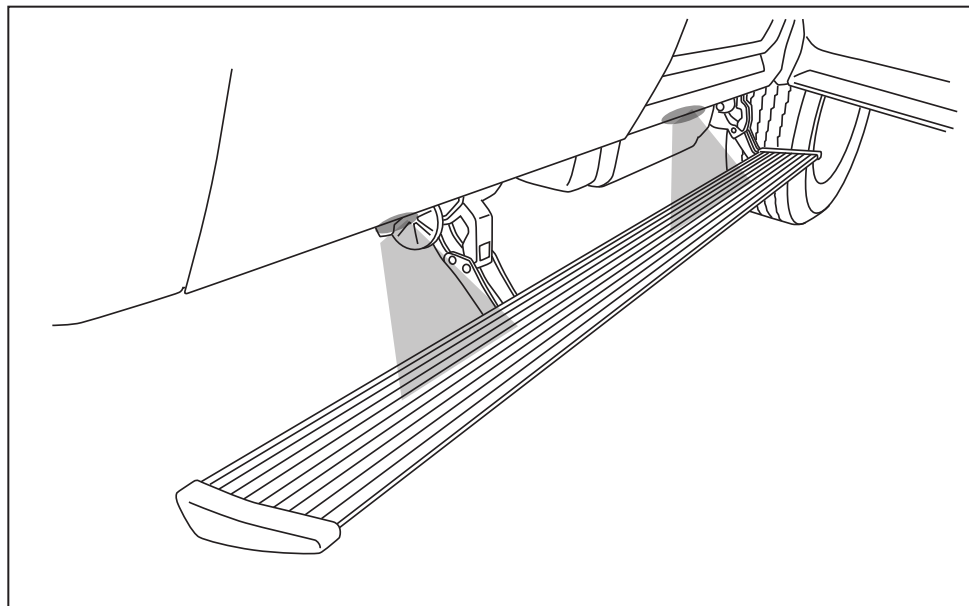

INSTALLATION TIME

3-5 Hours

Professional installation recommended

SKILL LEVEL



4= Experienced

TOOLS REQUIRED

- Safety goggles
- Measuring tape
- Power Drill
- 9/32" drill bit
- 10 mm socket
- 13 mm socket
- 21 mm socket
- Ratchet wrench and extension
- Wire crimpers
- Wire stripper / cutter
- 3/16" hex key wrench (allen wrench)
- 4mm hex key wrench (allen wrench)
- Electrical tape
- Weather proof caulking (silicone sealer)
- Silicone spray

Scan the QR code with your smartphone to view videos on YouTube.



<http://youtu.be/i7tkWahELEY>



<http://youtu.be/da2n8KxwasU>

WARRANTY

5-Year Limited Warranty

AMP RESEARCH TECH SUPPORT 1-888-983-2204 (Press 2) Monday - Friday, 6:00 AM - 5:00 PM PST

Invented, engineered and manufactured exclusively by AMP Research in the USA. May be covered by one of the following patents: 6,641,158; 6,830,257; 6,834,875; 6,938,909; 7,055,839; 7,380,807; 7,398,985; 7,584,975 ©2012 AMP Research. All rights reserved. Printed in USA.

INSTALLATION GUIDE

Attaching motor to Linkage assembly. **To be assembled in Step 6.**

EXPLODED VIEW

80-03129-90	Motor
19-03179-90	Socket cap screw
19-03133-90	Washer
19-03138-90	Drive Gear Housing Cover

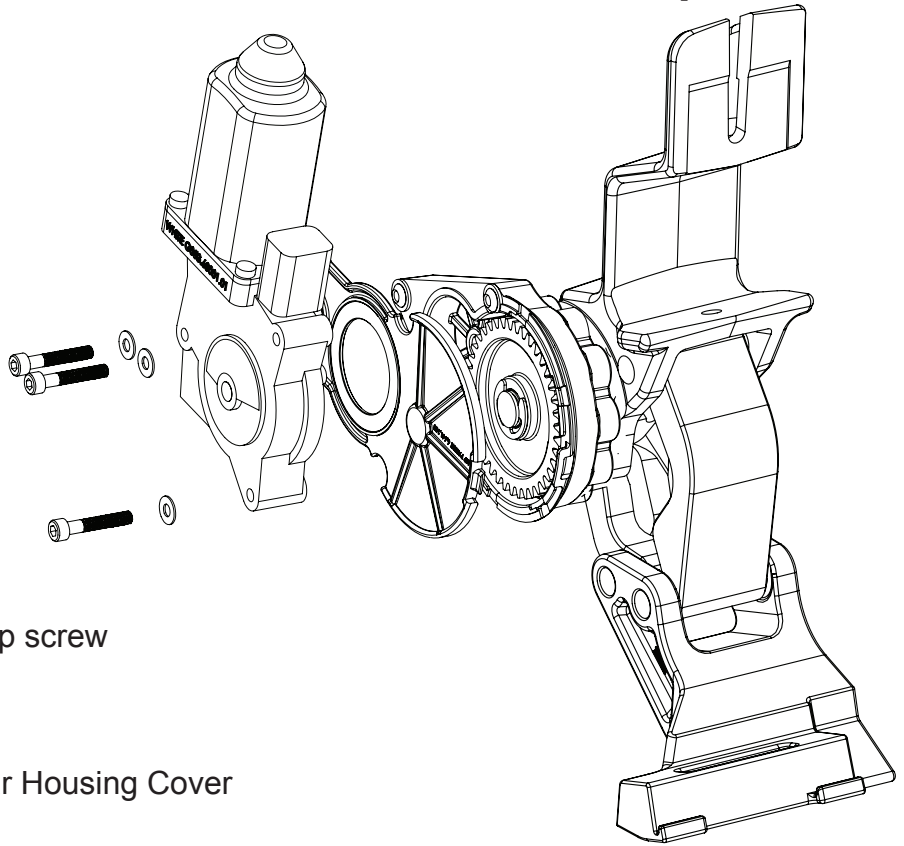
**CAUTION: HANDLE WITH CARE.**

The motor must be put on in Step 6 after the linkage is tightened to the body of the vehicle.

To ensure our customers receive all components with full integrity, we pack the motors separate from their linkage assemblies. This requires that the installer position and fasten the motor before continuing with the install. Please follow the instructions below and handle the assembly carefully.

CAUTION: Dropping the assembly or any excessive impact MAY cause damage to the motor.

Instructions:

1. Position the gear cover in place as shown if not already in place.
2. Seat motor into position on the three mounting bosses. This may require an adjustment of the gear by moving the swing arms.
3. After seating into place, fasten the motor with the three motor mount screws with 4mm Hex Head. Tighten screws to 36 in-lbs (4N-m). **Do not over torque.**

Note: Some Applications require modification.

Application

Crew Cab
Extended Cab

Cut Length

85" (No Modification Required)
79" (Trim 6" off of Board)

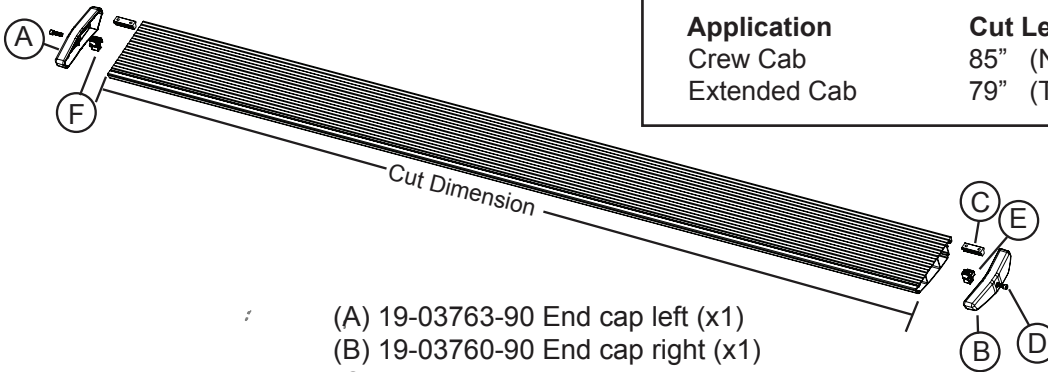

- (A) 19-03763-90 End cap left (x1)
- (B) 19-03760-90 End cap right (x1)
- (C) 18-02663-90 T-nut insert (x2)
- (D) 19-02802-90 Socket cap screw (x2)
- (E) 19-03761-90 End cap wedge right (x1)
- (F) 19-03764-90 End cap wedge left (x1)

1 x2

Running board assembly

Note: The jogs in the lower part of the linkages point toward one another.

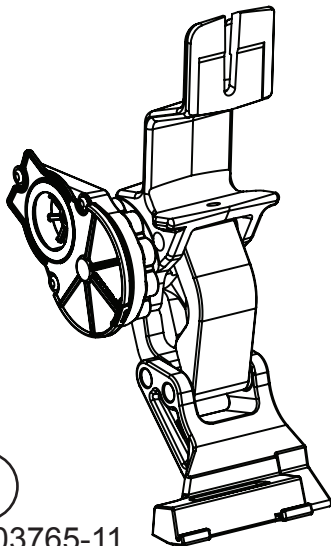

2

10-03765-11
Driver Motor Linkage assembly

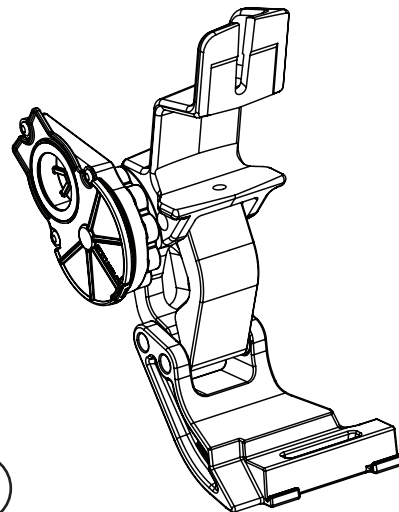

2

10-03765-12
Passenger Motor Linkage assembly

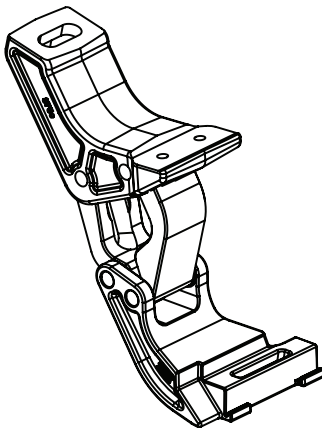

3

10-03766-11
Driver Idler Linkage assembly

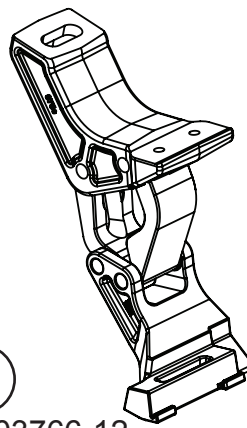

3

10-03766-12
Passenger Idler Linkage assembly

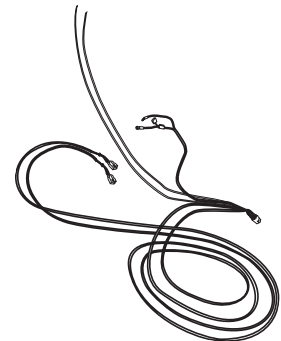

4

19-03969-90L
Wire harness

AMP RESEARCH POWERSTEP™ – CHEVROLET / GMC

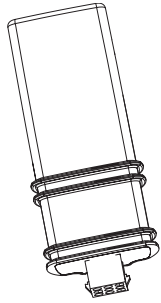

5
19-03297-A06
Controller

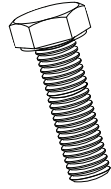

6 x6
19-03326-90
Hex Bolt



7 x6
16-03014-90
Washer

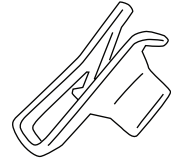

8 x2
19-03467-90
U-nut

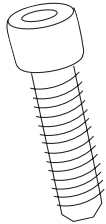

9 x8
19-02802-90
Socket Cap Screw

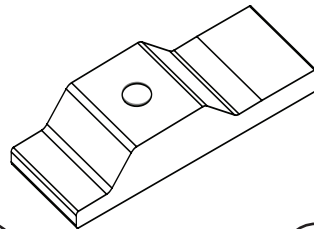

10 x2
20-03759-90
Fender Spacer

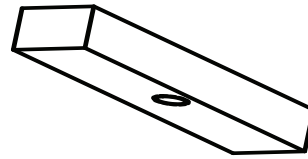

11 x2
17-03500-90
Threaded Clamping Plate

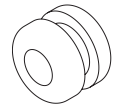

12
19-02640-90
Grommet



13 x20
19-02805-90
Cable tie (7")

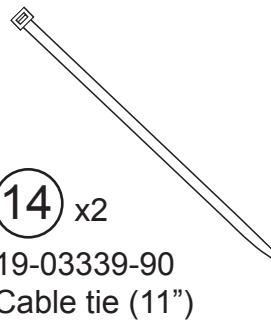

14 x2
19-03339-90
Cable tie (11")



16 x2
19-03985-90
Posi-Lock™

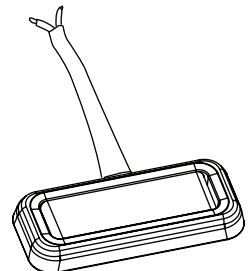

17 x4
19-03302-90
LED Lamp

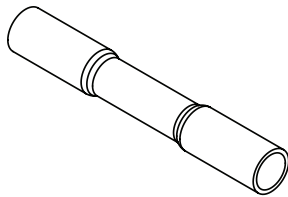

18 x8
19-03911-90
Butt Connector

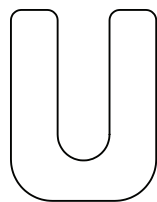

19 x2
19-03774-90
Shim



20 x2
19-03142-90
Shim
(Alternate shim. See step #1)

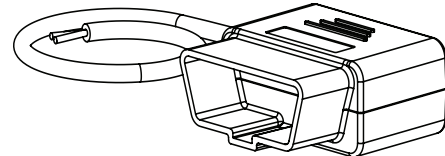

21
19-03970-90
OBD II Plug

FENDER TRIM PROCEDURE – CHEVROLET SILVERADO

Steps 1-6 are for Chevy Silverado Fender trimming. See Steps 7-11 for GMC Sierra Fender trimming

On Silverado model trucks trimming is required on the front fender trim.

1

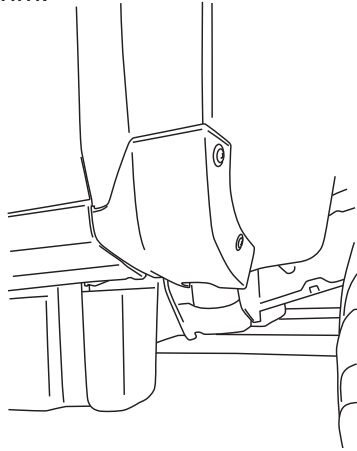

Using a T10 Torx bit remove two screws holding fender trim to fender.

2

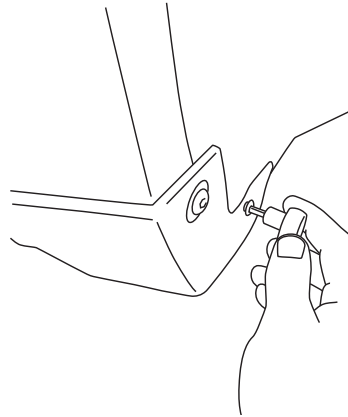

Once 2 screws are removed shift fender trim towards the rear of the vehicle to disengage plastic tabs.

3

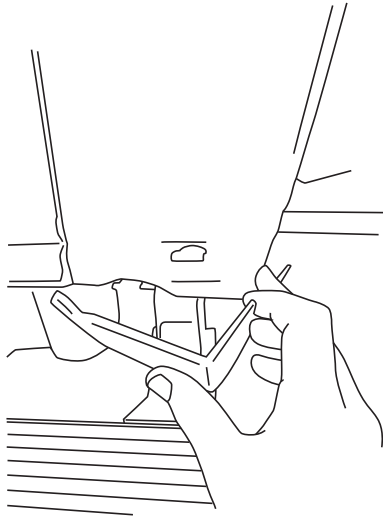

Cut out provided templates at the back of install sheet for the Chevy Silverado. Using tape line up template as shown.

4

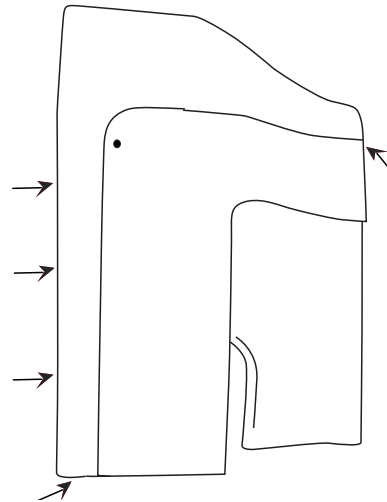

At center point use a 1" hole saw or spade bit. Once drilled we recommend using a band saw to trim the straight edges. Once trimmed deburr and reinstall fender trim.

5

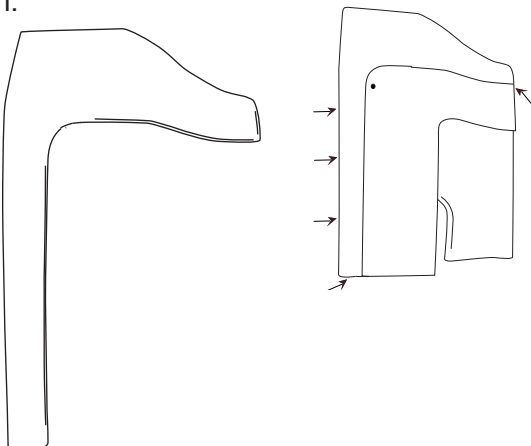

Reinstall fender trim and continue with powerstep installation.

6

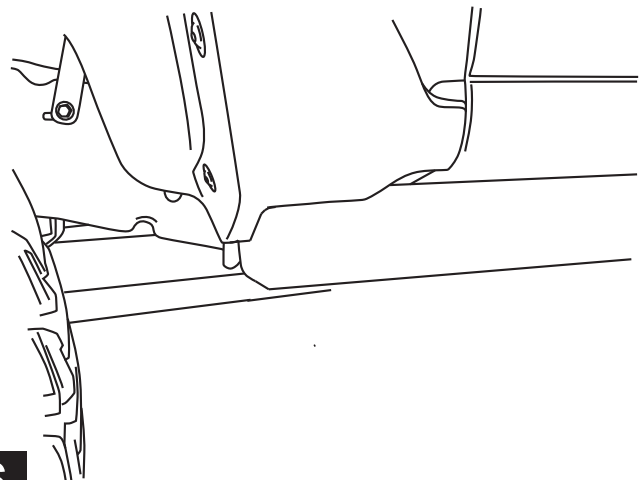

FENDER TRIM PROCEDURE – GMC SIERRA

Steps 7-12 are for GMC Sierra Fender trimming

Locate and drill out pop rivets that attach the metal bracket to the fender trim. Use a 9/32" drill bit.

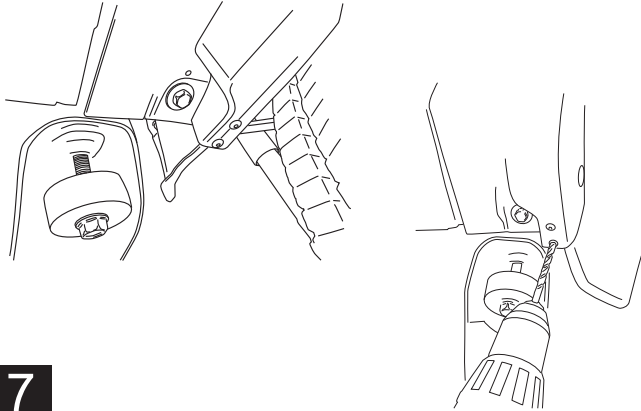

7

Using a 13mm socket or wrench remove the fender bracket from the trim

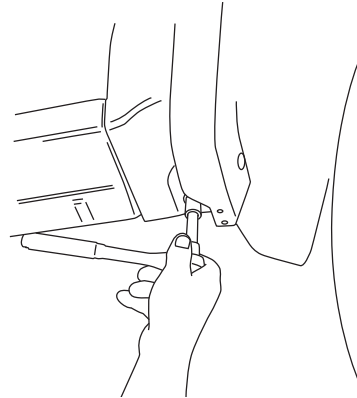

8

Remove the 2 T10 screws from the lower portion of the fender trim.

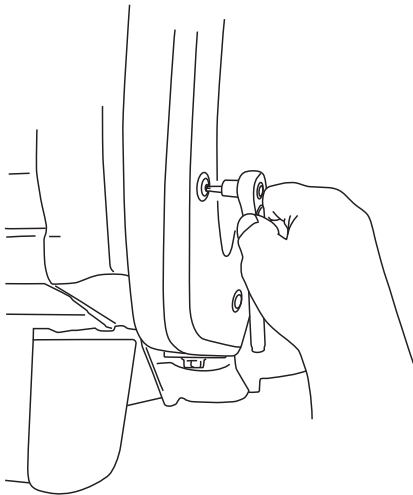

9

Cut out provided templates at the back of install sheet for the GMC Sierra. Using tape line up template as shown.

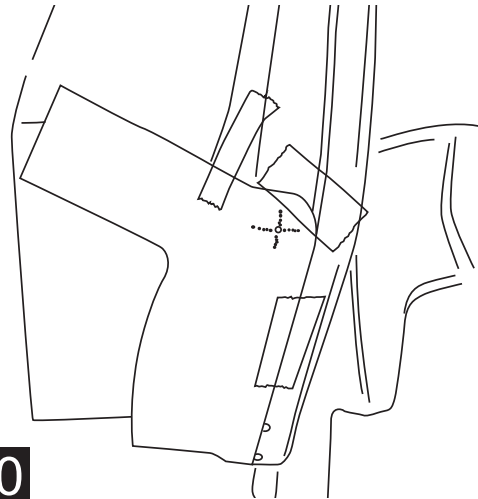

10

At center point of template use a 1" hole saw or spade bit. Drill through to create a radius. Once drilled we recommend using a dremel tool or die grinder to trim the straight edges. Once trimmed deburr and reinstall fender trim screws from step 9.

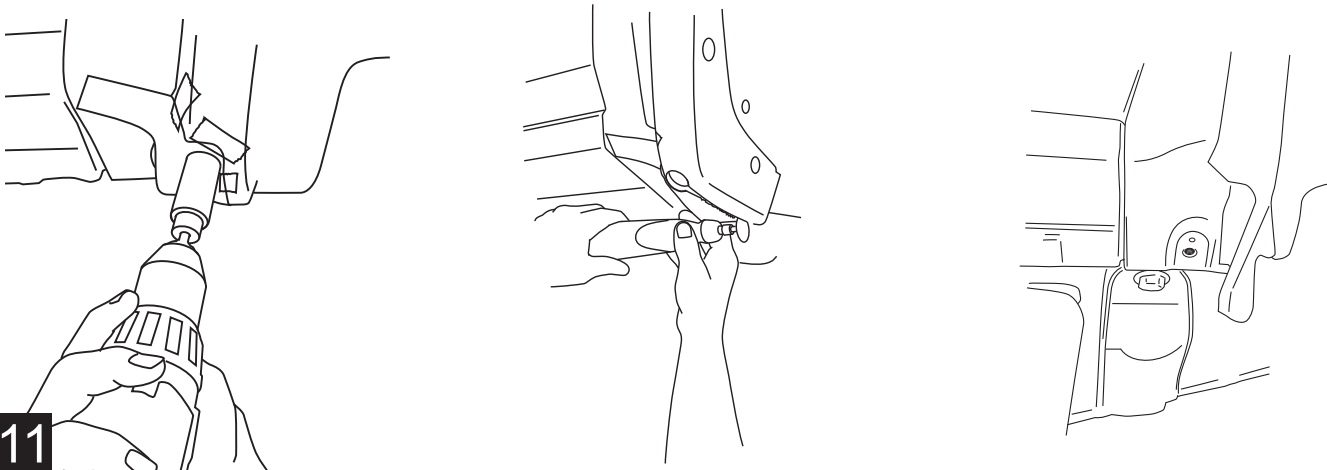

11

AMP RESEARCH POWERSTEP™ – CHEVROLET / GMC

Remove Passenger and Driver side Fender and body mount bolt. Body mount bolt will be reused. Install front Idler Linkages.

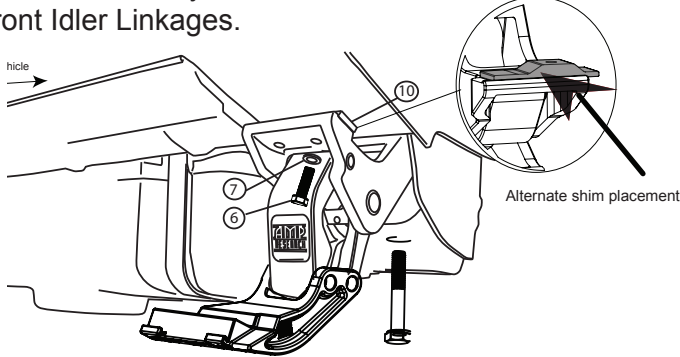

Install Fender Spacer between fender and Idler Linkage (10) Spacer hole and mounting hole faces towards front of vehicle. Install fastener (6) with washer (7), and replace Body mount bolt. Finger tighten only. Note: Due to build differences the alternate shim (20) on parts list may be needed between body spacer (10) and linkage upper mount.

1

Install Passenger and Driver side Motor Linkage in fourth sheetmetal tab / hole from front. Extra Cab: See measurements below for location.

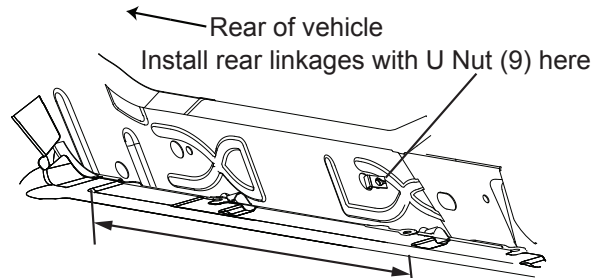

Crew Cab- Approx 26 1/4" from back of cab
Extended Cab- Approx 11" from back of cab

2

Install threaded clamping plate (11) on top of pinch weld and thread fastener (6) with washer (7) into clamping plate. Finger tighten bolt. Install fastener (6) with washer (7), finger tighten only.

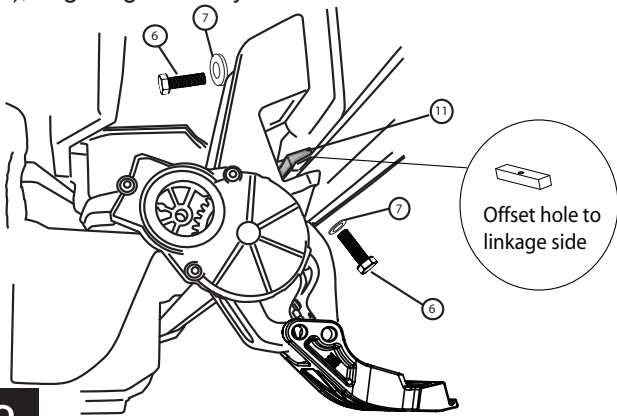

3

Slide mounting T-nut into position, slide the board back so that the front end cap is against the front Linkage. Finger tighten only.

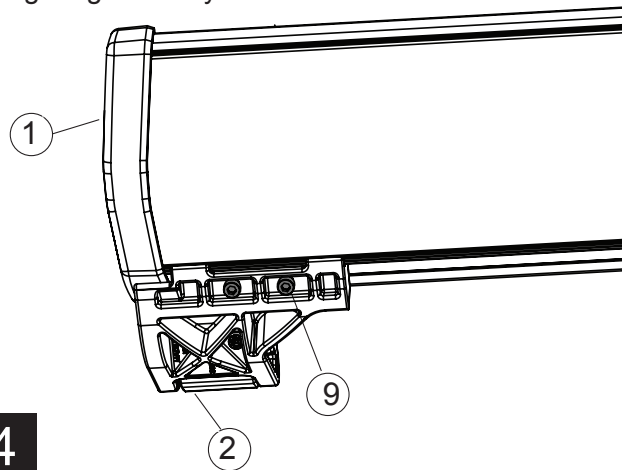

4

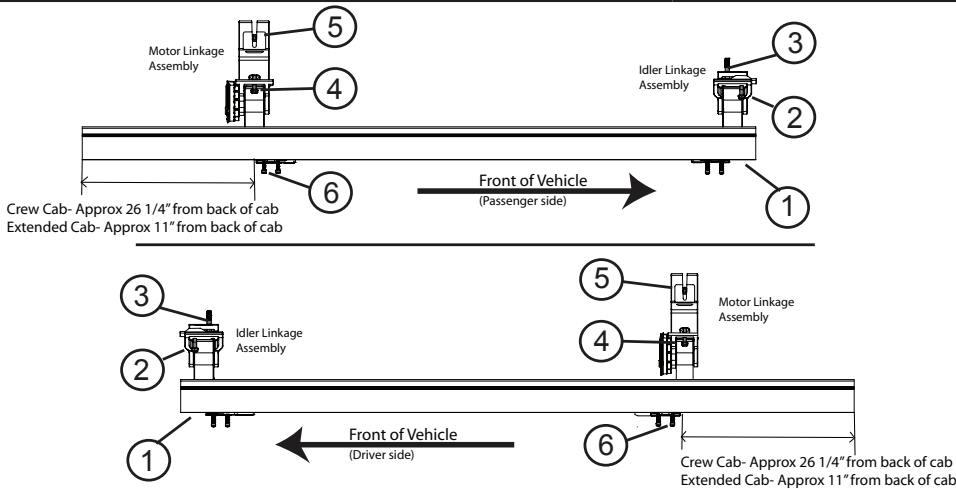

Note: Due to vehicle-build variations the Power Step may not correctly align with vehicle cladding. Provided Shims (19) may need to be installed between body mount and idler linkage once Power Step is installed.

Note: After each step of the torquing process check for binding in the system. Steps should deploy under own weight.

In order to prevent any binding follow the torquing order listed above.

1) Torque Socket cap screws to 10 ft-lbs. 2) Torque Hex head screw to 16 ft-lbs. 3) Torque body mount bolt to 44 ft-lbs. 4) Torque Hex head screw to 16 ft-lbs. 5) Torque Hex head screw to 16ft-lbs. 6) Torque Socket cap screws to 10 ft-lbs.

5

Install motor onto Motor Linkage Assembly. See page 2 for motor installation instructions.

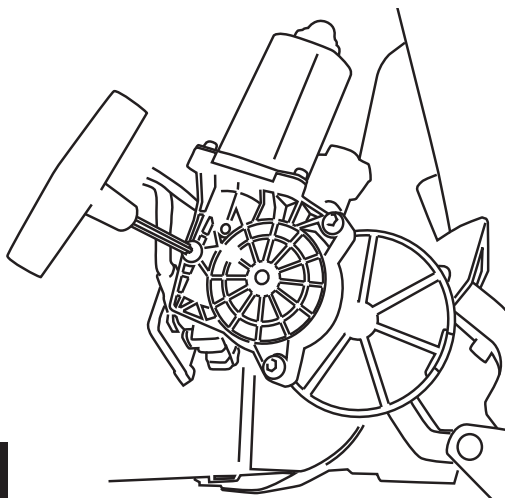

6

Using the two 11" cable ties, mount controller to the support arm next to the battery.

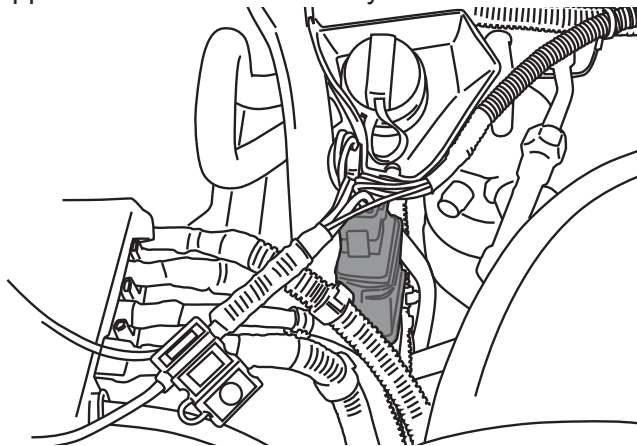

7

Plug in wire harness.
(Ensure that locking tabs engage.)

Remove fuse from harness.

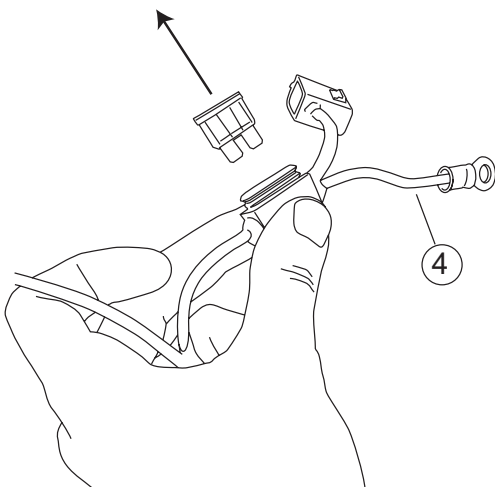

8

Attach power lead (RED wire) to positive pole on the battery and Negative lead (BLACK wire) to negative pole on the battery.

CAUTION: Do not ground wrench when engaged

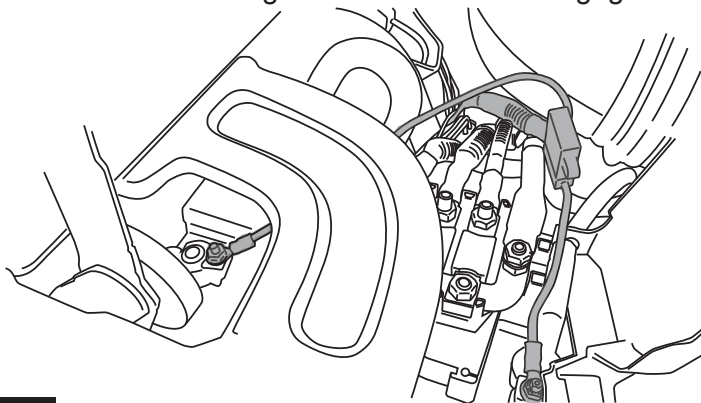

9

Route long end of wire harness above engine and down through drivers side wheel well. Zip tie harness to cowling clips on fire wall. Route short end down passengers side.

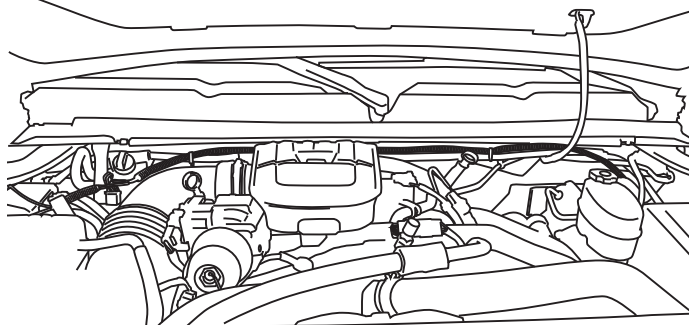

10

Secure with zip ties.

11

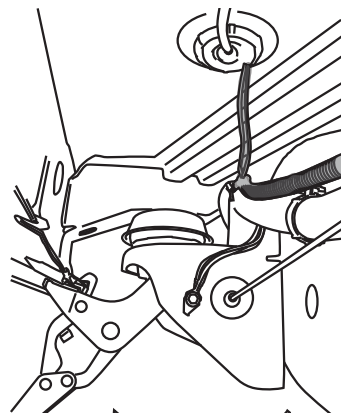

Route wire harness along the frame and back towards rear linkage. Secure with zip ties. Poke hole through rubber grommet near front door on underside of floor panel with small phillips screwdriver. Push both wires through hole. (See Step13 for passenger side notes.)

Pull up front door sill plate covers as shown.

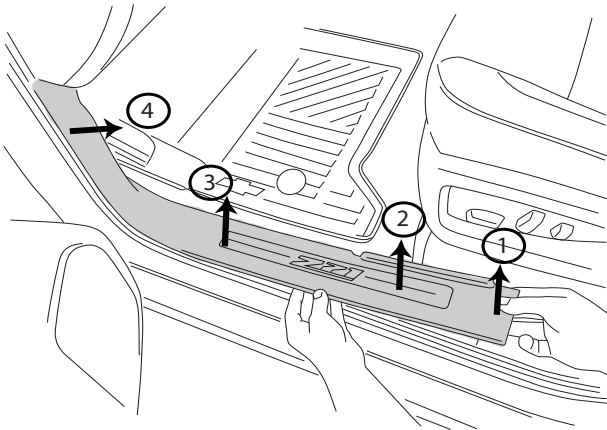

12

Pull up carpet and drill a 9/32" hole in floor and add rubber grommet)

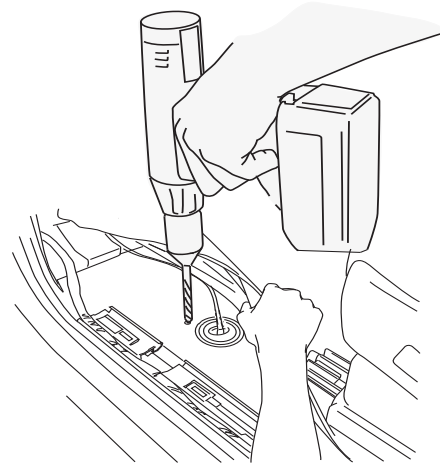

13

Pull up the carpet and thread both wires through the floor panel

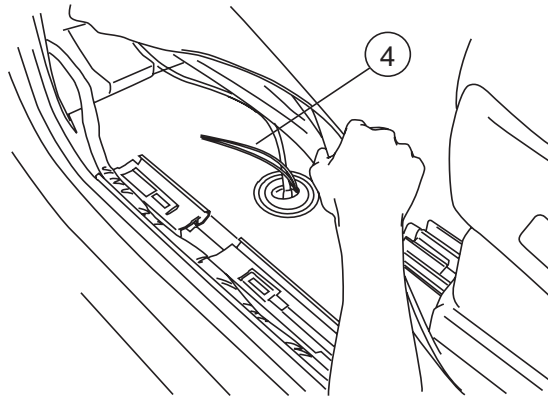

14

Seal holes with silicone glue and cover with tape so carpet does not stick to glue.

Route wire harness along the frame and back towards rear linkages. Secure with zip ties. Push both wires through rubber grommets.

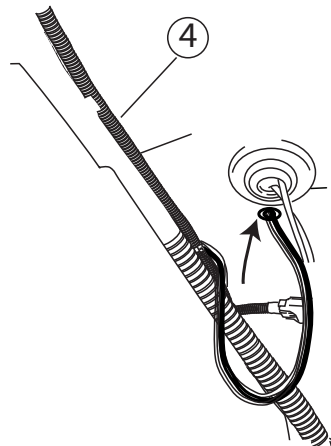

15

AMP RESEARCH POWERSTEP™ – CHEVROLET / GMC

On each side of the vehicle measure from the front edge of door line on the pinch weld to the specified lengths below. Measure at 22" for front LED Light and 65" for rear LED Light.

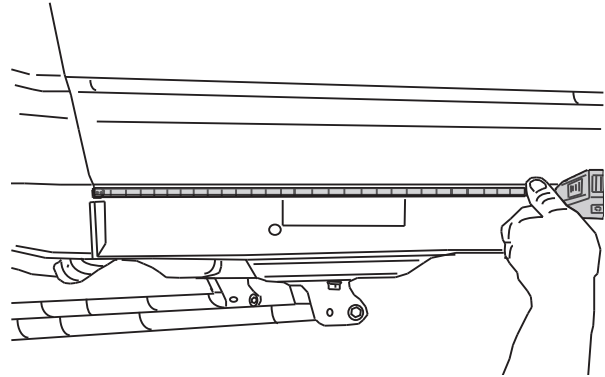

17

Affix lamp to rocker panel surface. Make sure the lamp is affixed to a clean, flat surface. There is a step down midway across the surface. Affix lamp just outside of step down.

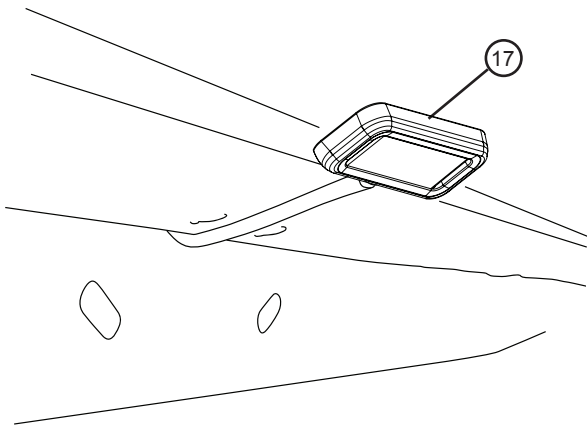

18

Using supplied butt connectors, connect the lamp wires. Red to Red, Black to Black. Once Crimped use heat gun to shrink tube.

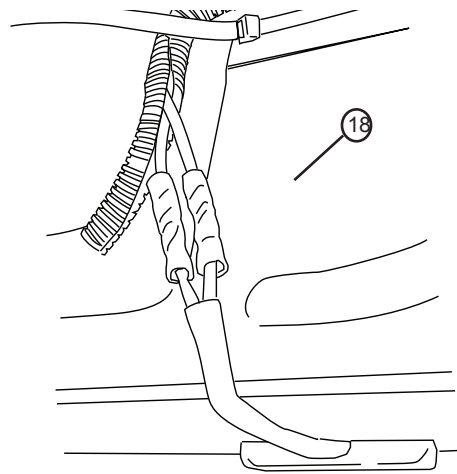

19

Close and wrap with conduit and electrical tape. Secure all loose wires with cable ties, with lamp wires pulled upward to avoid any wire snagging.

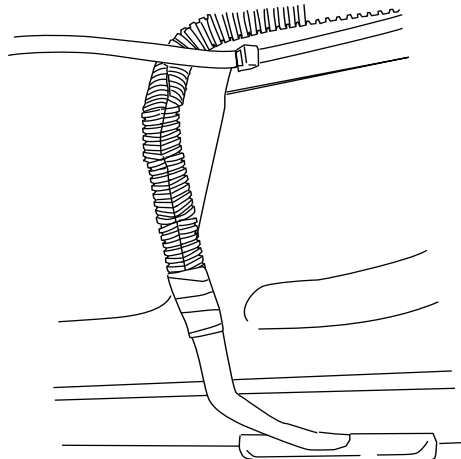

20

Reinstall fuse.

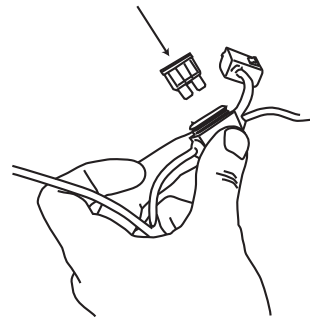

21

OBD II install: Use Supplied Posi Twist connectors to attach the Plug and Play Module to the Harness. Attach matching colors on the harness to the wires on the module. Plug in module to OBD II port on the vehicle. Secure harness with supplied tie wraps.

Note: If the OBD II pass thru harness (76404-01A) was purchased see install sheet supplied in packaging. The pass through harness allows for an open port for other accessories. See below for a brief description.

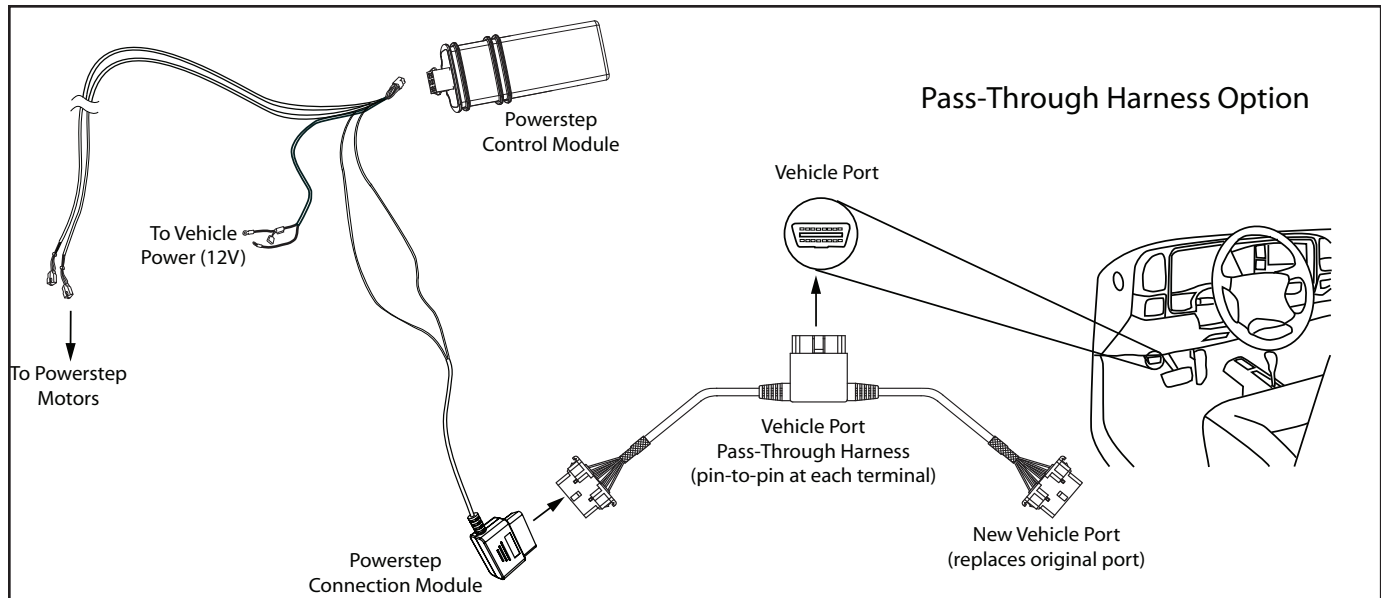
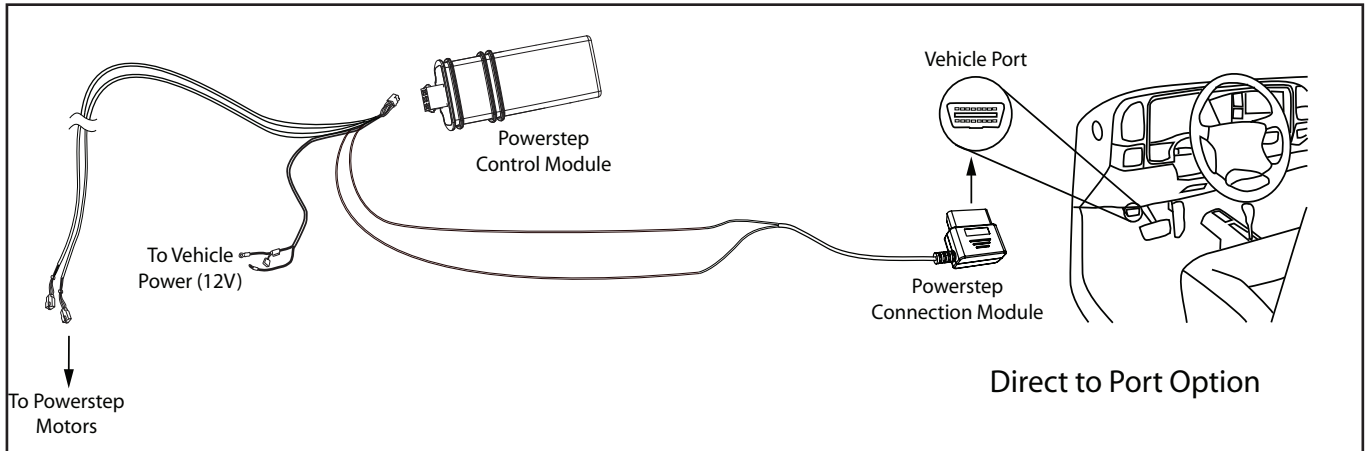
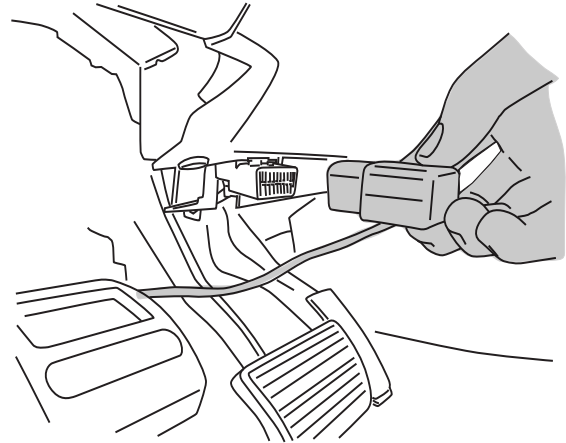
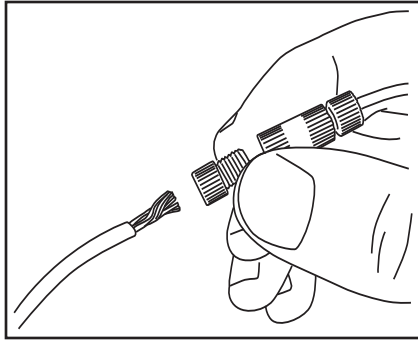

Check that all doors activate the Power Step and the LED Lights work when doors open and close. Reinstall any remaining trim panels.

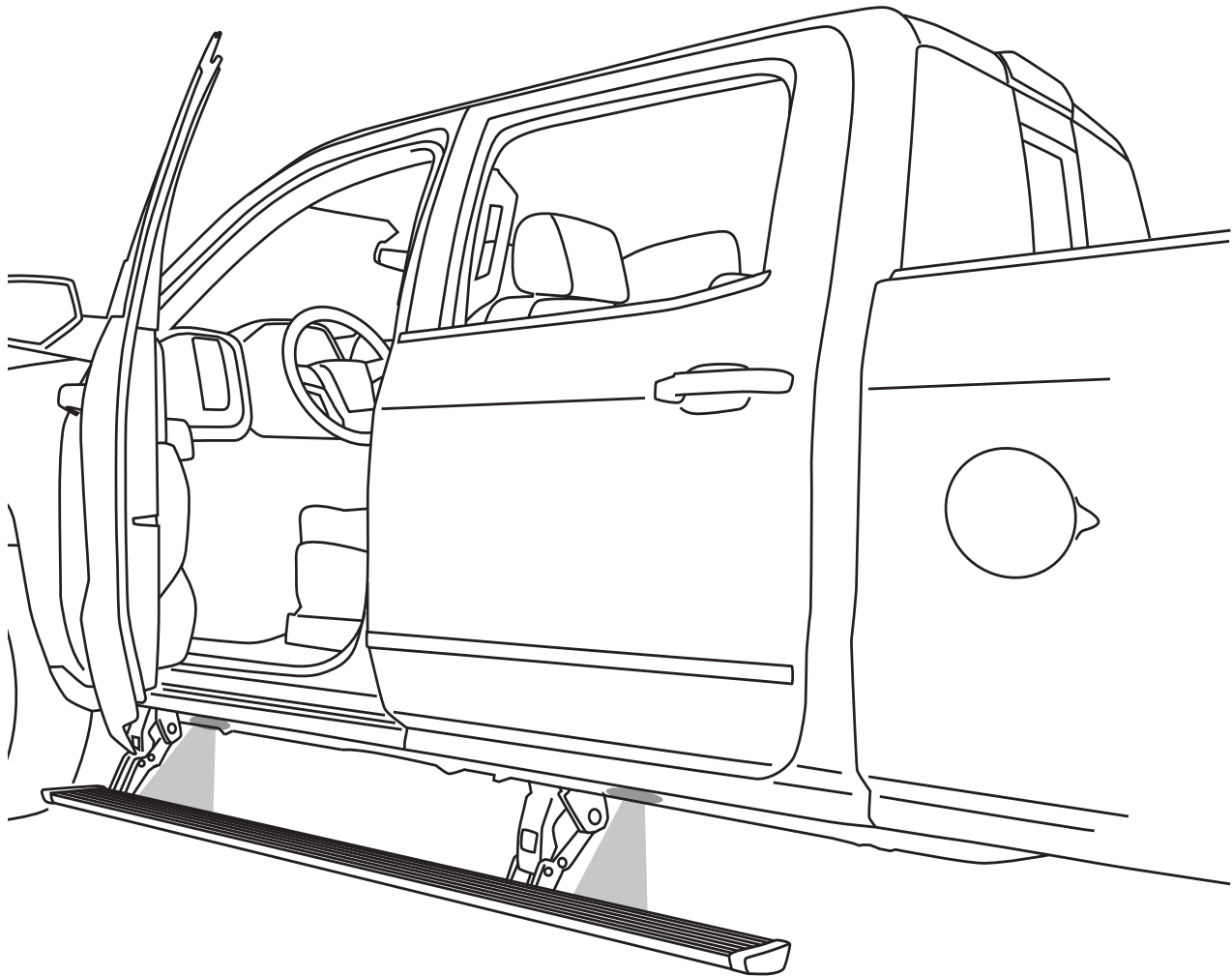

FINAL SYSTEM CHECK

Check that all doors activate the PowerStep and the LED lights work when doors open and close.

NORMAL OPERATION: When the doors open, PowerStep automatically deploys from under the vehicle.

When the doors are closed, PowerStep will automatically return to the stowed/retracted position. **Note that there is a 2-second delay before the PowerStep returns to the stowed/retracted position.**

CORRECT OPERATION OF LIGHTS: All four lamps will illuminate upon opening any door of vehicle. Lamps will stay on until restowing of both Power Steps or until 5 minutes has expired with the doors open. When the lights timeout after 5 minutes, they can be reilluminated by closing and opening any door of vehicle.

POWER-DEPLOYABLE RUNNING BOARDS OPERATION: AMP Research PowerStep running boards automatically move when the doors are opened to assist entering and exiting the vehicle.



Automatic power deploy:

The running boards will extend down and out when the doors are opened.

Automatic power stow:

The running boards will return to the stowed position when the doors are closed. There will be a 2-second delay before the running boards move to the stowed position.

Automatic stop:

If an object is in the way of the moving running board, the running board will automatically stop. To reset, clear any obstruction, then simply open and close the door to resume normal operation.



Manually set in the deployed (OUT) position for access to the roof:

The running boards can be manually set in the deployed position by firmly holding the step down with your foot while at the same time closing the door. To resume normal operation, open and close the door.

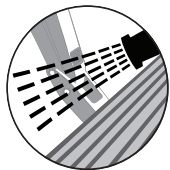

Maintenance: In adverse conditions, debris such as mud, dirt, and salt may become trapped in the running board mechanism, possibly leading to unwanted noise. If this occurs, manually set the running boards to the deployed position and flush the front and rear hinge arms with a high-pressure car wash wand.

Avoid spraying the motors directly. After washing, apply silicone spray lubricant to the hinge pivot pins. Do not apply silicone, wax or protectants like Armor All® to the running board stepping surface.

Caution! Keep hands away when the running board is in motion.

5-YEAR LIMITED WARRANTY

AMP RESEARCH warrants this product to be free from defects in material and workmanship for FIVE (5) YEARS FROM DATE OF PURCHASE, provided there has been normal use and proper maintenance. This warranty applies to the original purchaser only. All remedies under this warranty are limited to the repair replacement of the product itself, or the repair or replacement of any component part thereof, found by the factory to be defective within the time period specified. The decision to repair or replace is wholly within the discretion of the manufacturer.

This warranty specifically excludes labor. If you have a warranty claim, first you must call our factory at the number below for instructions. You must retain proof of purchase and submit a copy with any items returned for warranty work. Upon completion of warranty work, if any, we will return the repaired or replaced item or items to you freight prepaid. Damage to our products caused by accidents, fire, vandalism, negligence, misinstallation, misuse, Acts of God, or by defective parts not manufactured by us, is not covered under this warranty.

ANY IMPLIED WARRANTIES OF MERCHANTABILITY AND/OR FITNESS FOR A PARTICULAR PURPOSE CREATED HEREBY ARE LIMITED IN DURATION TO THE SAME DURATION AND SCOPE AS THE EXPRESS WRITTEN WARRANTY. OUR COMPANY SHALL NOT BE LIABLE FOR ANY INCIDENTAL OR CONSEQUENTIAL DAMAGE.

Some states do not allow limitations on how long an implied warranty lasts, or the exclusion or limitation of incidental or consequential damages, so the above limitations or exclusions may not apply to you. This warranty gives you specific legal rights, and you may also have other rights that vary from state to state.

FOR WARRANTY ISSUES WITH THIS PRODUCT PLEASE CALL AMP RESEARCH CUSTOMER SERVICE 1-888-983-2204

WARNING

Be sure to read and precisely follow the provided instructions when installing this product. Failure to do so could place the vehicle occupants in a potentially dangerous situation. After installing or reinstalling, re-check to insure that the product is properly installed.

Silverado Driver Side Trim Template. Verify dimensions for template sizing.

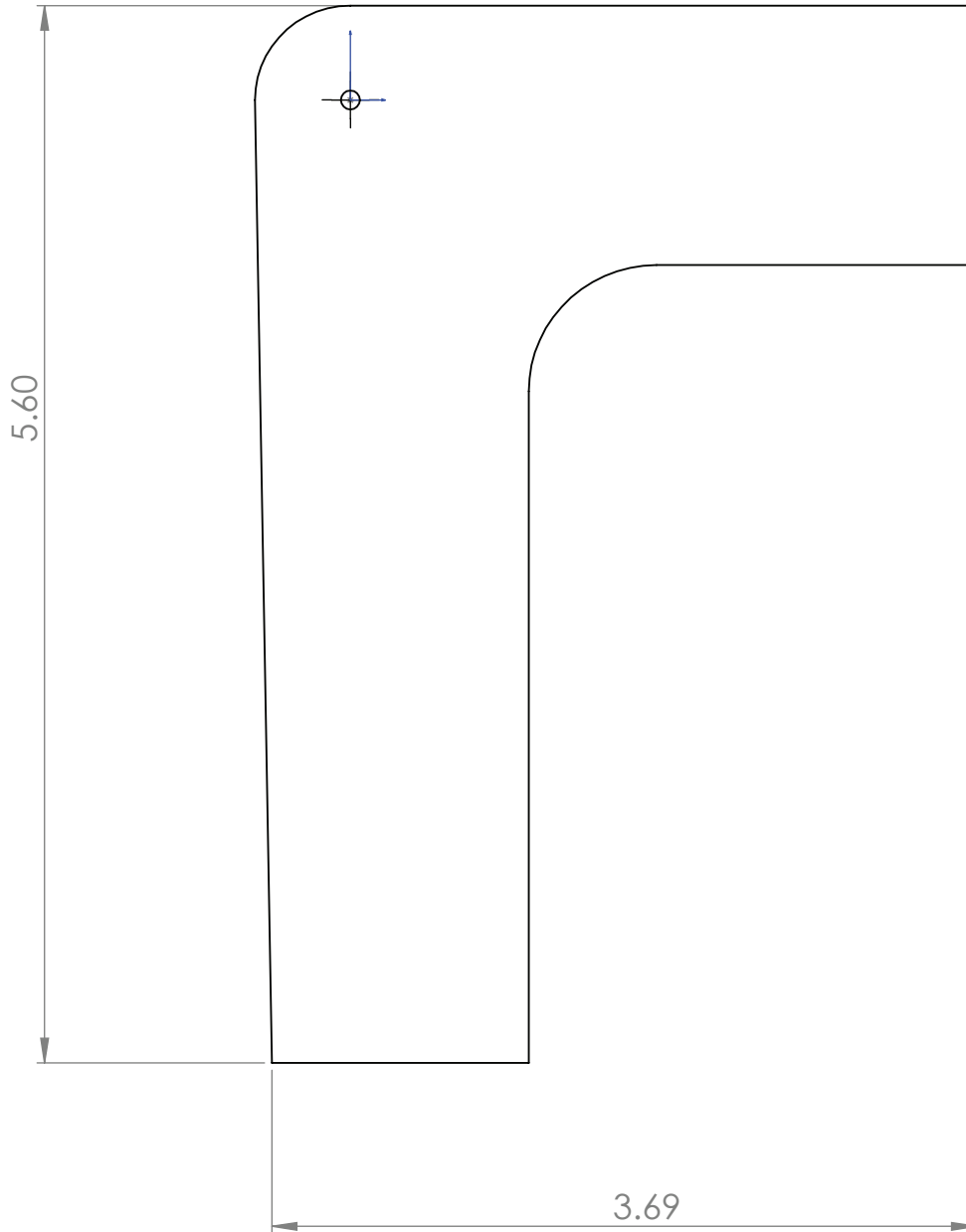

GMC Sierra Driver Side Trim Template. Verify dimensions for template sizing.

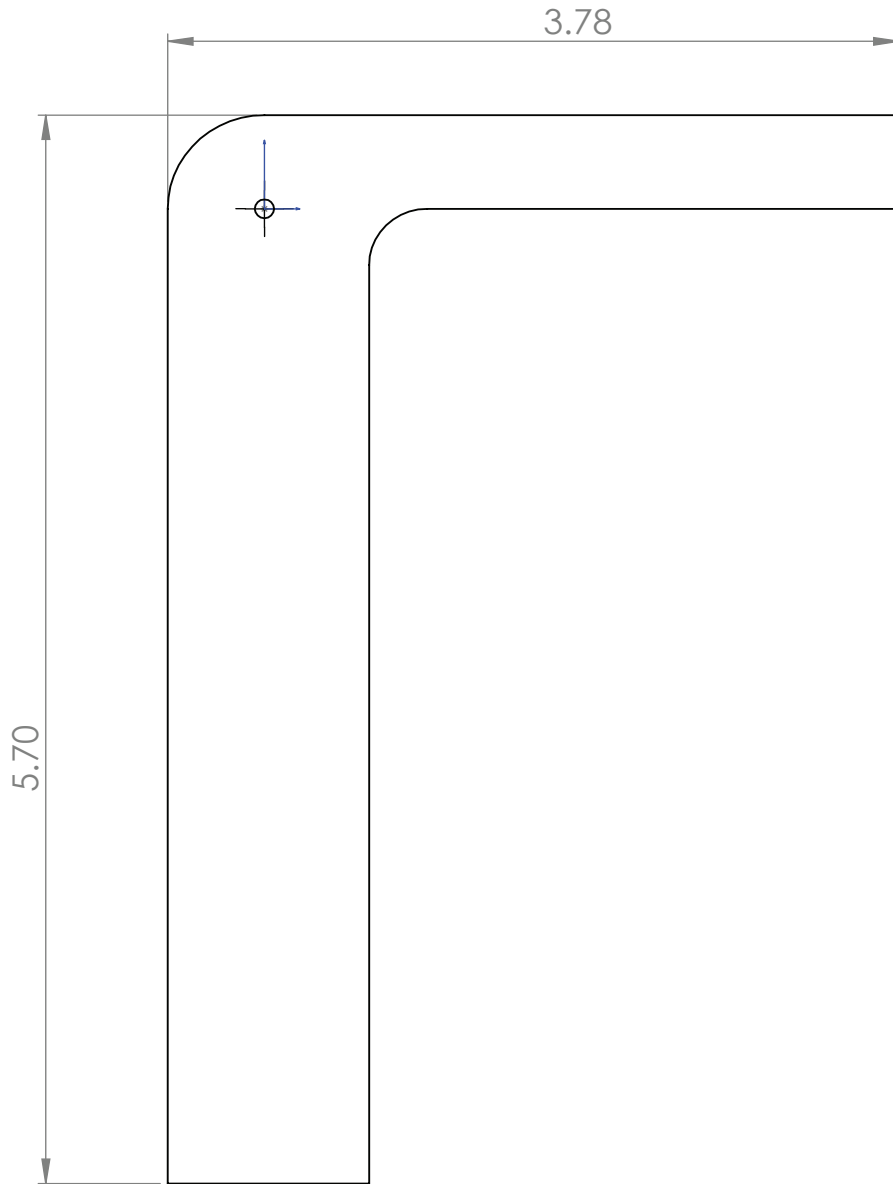

Silverado Passenger Side Trim Template. Verfiy dimensions for template sizing.

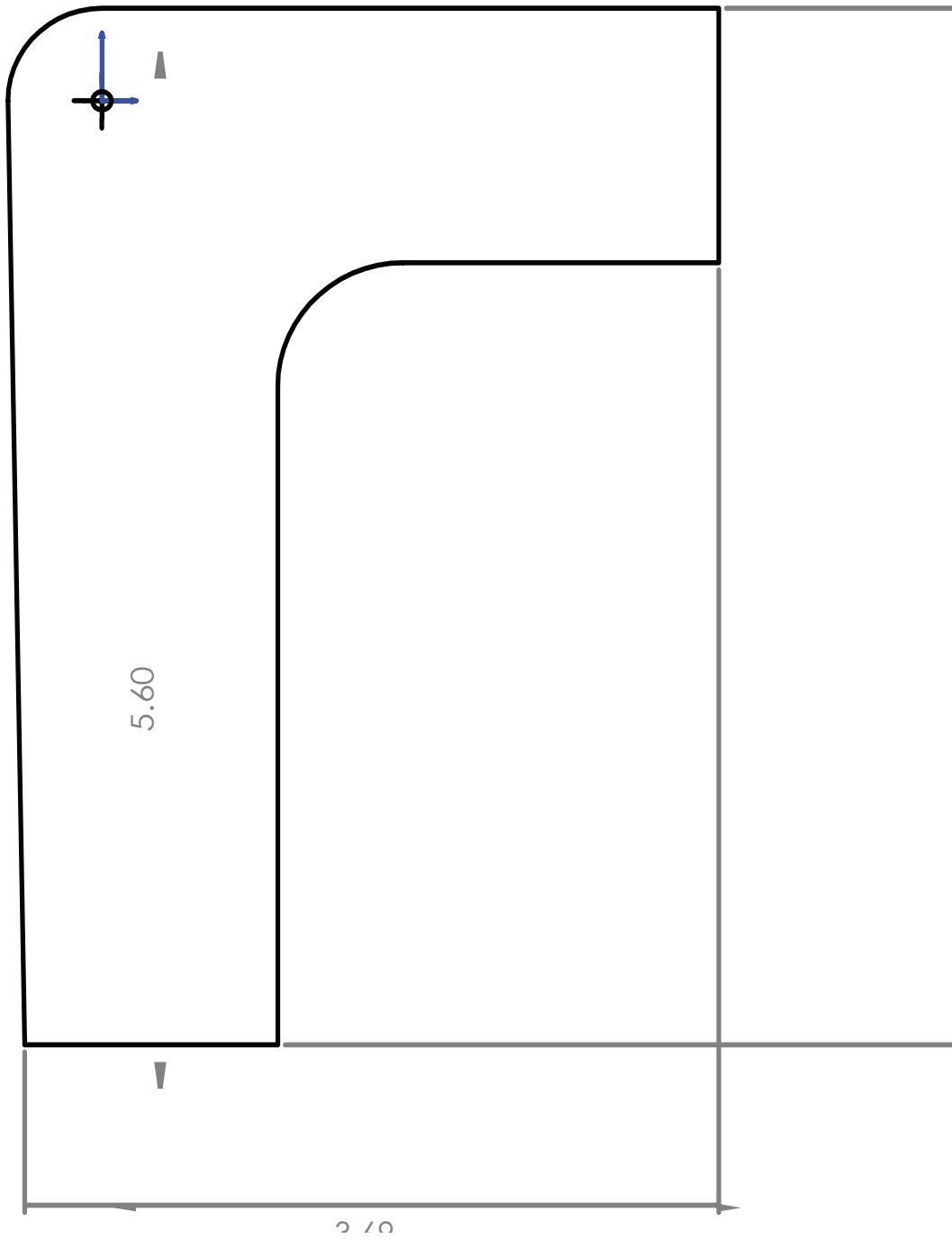

GMC Sierra Passenger Side Trim Template. Verify dimensions for template sizing.

