



2010 - 2018, Ram HD Dually
2019-Current Ram HD Dually with flare
Rear Mount Bracket for 21" Gatorback
Mounting Diagram & Instructions
For use with 21" Rubber
GB 768052

IMPORTANT:

The manufacturer is not responsible for negligent use of vehicle with mud flaps installed, including over-tightening of screws and bolts causing damage to vehicle or mud flaps.

TOOLS REQUIRED:

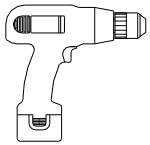

*Electric or re-chargeable
 1/2" or 3/8" drill*



#2 Phillips Screwdriver

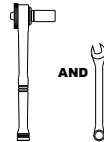

*3/8" and 5/16" wrench
 and socket set*



1/4" drill bit

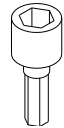

3/8" Socket Driver

KIT CONTAINS:

*(1) Mount Bracket,
 Rear, LH
 Part #755560*

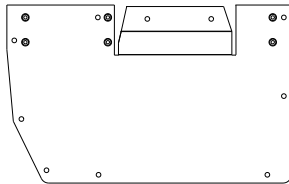

*(1) Mount Bracket
 Rear, RH
 Part #755561*

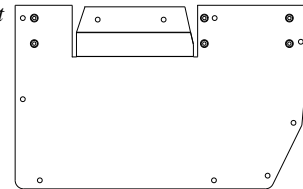

*(1) Brkt, Z, DS
 Part #750433*

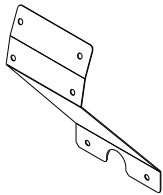

*(1) Brkt, Z, PS
 Part #750434*

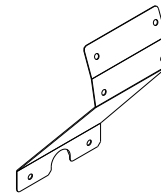

PARTS BAG #768051 CONTAINS:

*a) (42) Washer, Flat
 0.203" x 1" 18ga
 Part #018031*



*b) (12) T-Nut
 #8 - 32
 Part #016028*



*c) (20) Machine Screw
 #10 x 1.5"
 Part #012027*



*d) (2) Washer, Half
 0.203" x 1", 18g
 Part #018032*

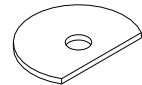

*e) (12) Machine Screw
 #8 x 0.313"
 Part #012023*



*f) (20) Nut, Hex, SS
 #10
 Part #025003*



*g) (20) Lock Washer
 #10
 Part #024001*



Note: 2010-2018 Models require less hardware than 2019-2020 Models. If you are installing on a 2010-2018 Model, you will have extra hardware

INSTALLATION

For ease of installation, it is suggested that the wheel be removed.

1. Before you install your Gatorback mud flap, see the diagram and parts list for all necessary parts. Start on driver's side.
2. Fasten the DS mount bracket to the DS flap (purchased separately) with six machine screws and six t-nuts. Please note that the holes in the bracket should line up with the dimples in the mud flaps (purchased separately). (See Diagram #1)

Diagram #1
Driver Side

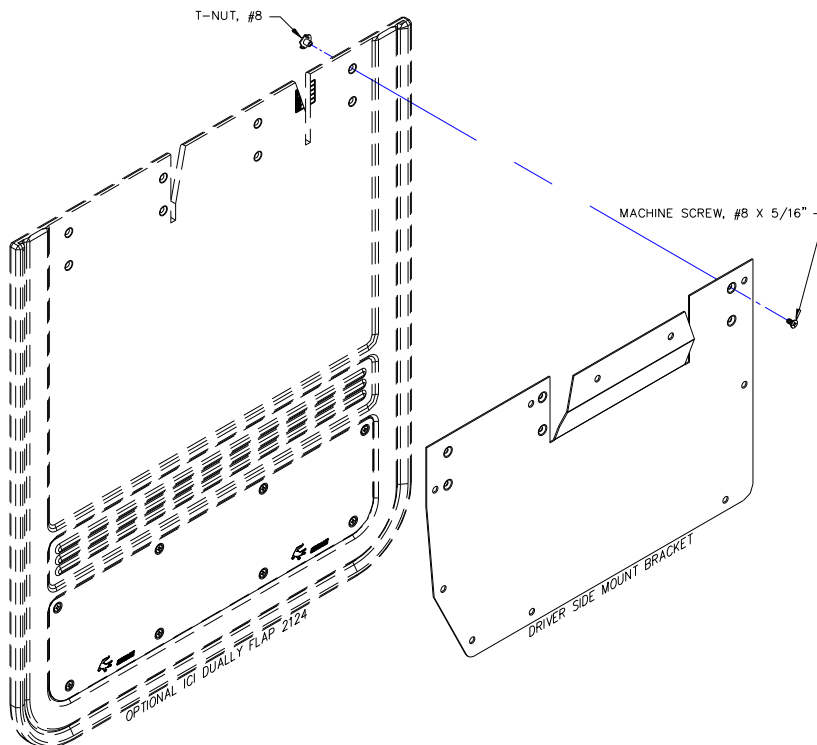

3. Cut rubber to match bracket profile and drill 10 holes through the bracket holes that do not align with t-nuts into the mud flap. (See Diagram #2)

Diagram #2
Driver Side

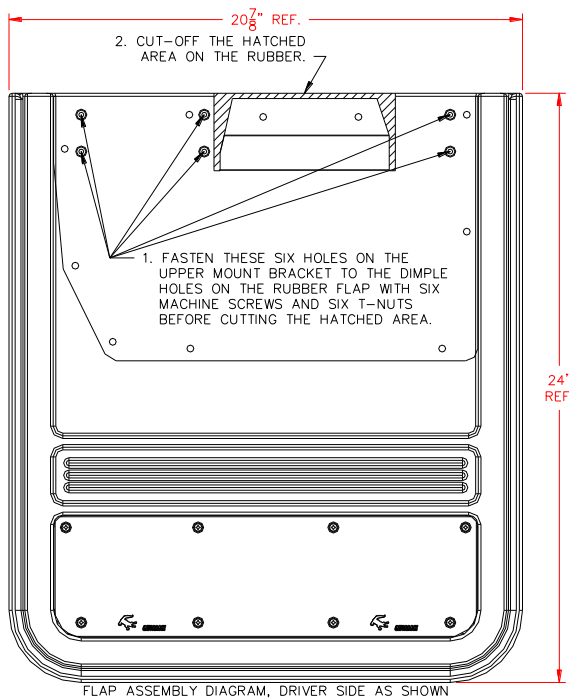

4. Remove factory harness mounts A & B with harness and reinstall to the "Z" bracket holes C & D. (See Diagram #3)
5. Bolt the upper holes of the "Z" bracket to the existing factory push screw holes A & B with two machine screws, four flat washers, two lock washers and two hex nuts. (See Diagram #3)
6. Remove the factory screws #12 & #13 on the wheel flare as shown on the diagram and reinstall the two factory screws with two flat washers (0.203" x 1") on holes #1 and #3 through the factory holes #12 and #13.
7. Drill a 1/4" hole (7 places) from holes #4 to #10 through the factory tub liner then fasten holes #6 & #7 with two machine screws, four flat washers, two lock washers and two hex nuts through the factory tub liners and Z bracket. Fasten hole #4 using a machine screw, flat washer, half washer, lock washer, and hex nut. For the remaining holes, #5, #8 to #10 with four machine screws, 8 flat washers, four lock washers & four hex nuts through the factory tub liners. (See Diagram #3)
- 7a. For 2019-2020 models: Drill a 1/4" hole from the back lower corner of the factory plastic molding through the rubber flap and then secure the flap to the molding using a machine screw, two flat washers, a lock washer, and a hex nut.

✓ Check all fasteners for tightness. Repeat procedure on the other side.

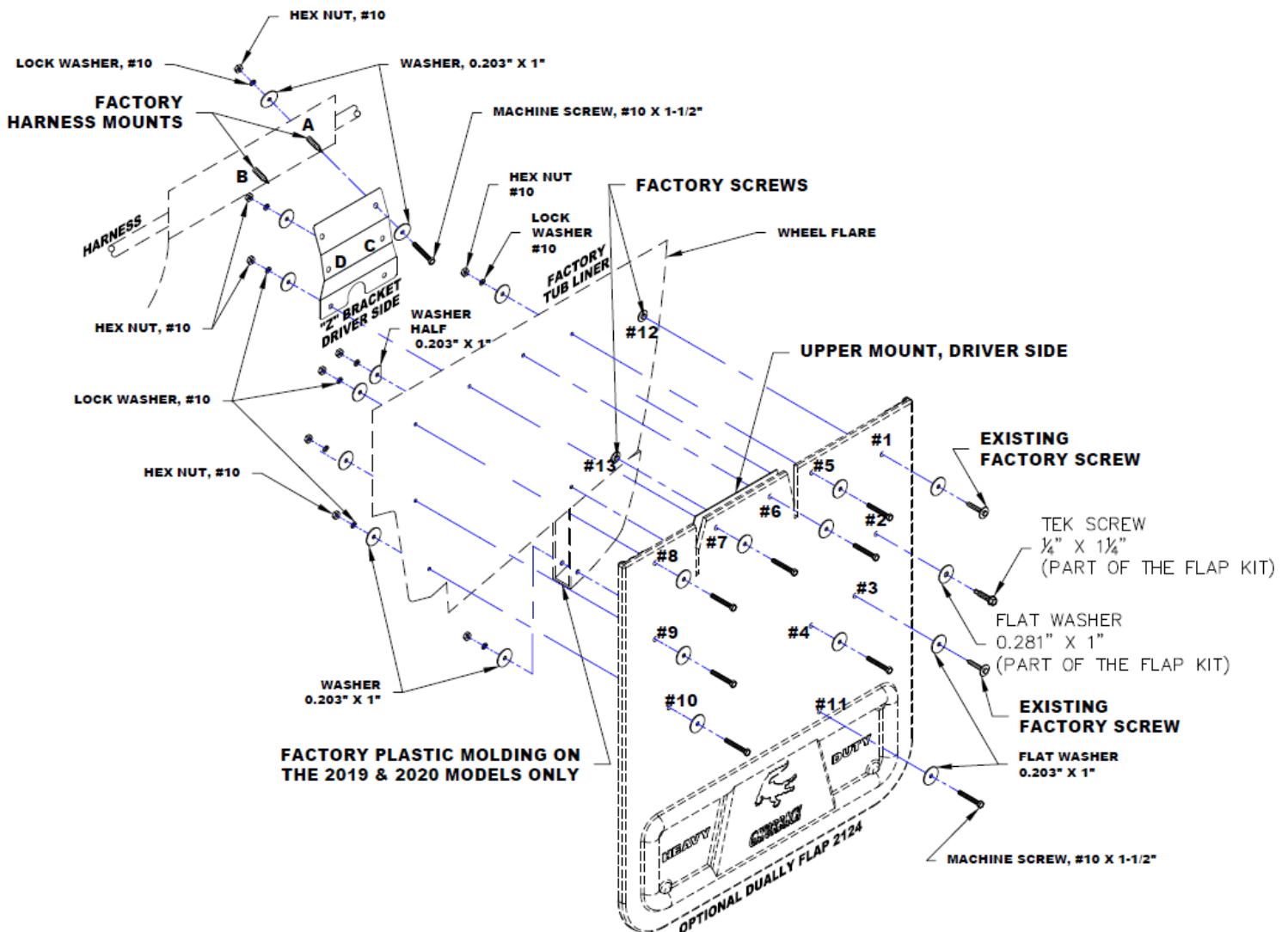

Please check out our YouTube channel to see an install video for this application.

