

Big Tex Grille Guard

Installation Instructions

77749 & 77749B

GMC Sierra 1500

2014 - 2017

Some models without tow hooks, will require the plastic tow hook pocket to be trimmed for bracket clearance.

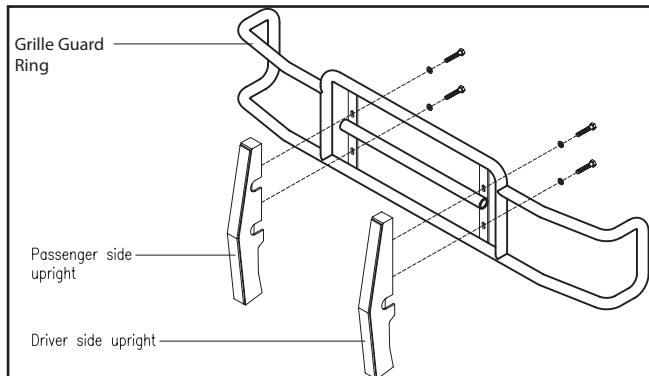

Diagram 1

Parts List:

1 - Grille Guard Ring	2 - 1/2" x 1" Bolts
1 - Driver Side Upright	20 - 1/2" Flat Washers
1 - Passenger Side Upright	18 - 1/2" Lock Washers
1 - Driver Side Bracket #77749-7	2 - 1/2" Nuts
1 - Pass. Side Bracket #77749-8	
2 - Nut Plates #77736-9	
18 - 1/2" x 1 1/2" Bolts	*May include extra hardware.

Note: Completely read instructions before beginning installation!

1. Remove the contents from the box and check for missing pieces or damage. If parts are missing or damaged, contact the original place of purchase.
2. The two factory bolts attaching each tow hook to the frame will need to be removed. The long front driver side bolt will need the head cut off to be able to slide it out of the frame toward the outside. This can be done with a saw or cutoff wheel. The front passenger side long bolt will not need to be cut, as there is enough room to slide it out. If cutting the bolt is not an option the bumper will need to be temporarily removed. Step # 4 describes the bumper removal process below.
3. If the vehicle does not have tow hooks, the lower plastic panel will need to be trimmed and/or removed to create access for the brackets to attach to the frame. On some models there are removable tow hook cup panels in front of the frame that can be removed instead of being cut, but will require the bumper to be temporarily removed, which is described in step #4.
4. **This step is for the removal of the front bumper, which is an alternative way to gain access to bolts and panels needed for the install.** Gently unclip and remove (1) screw from each side of the plastic lower fender trim that goes over the under-headlight plastic panel ends. Gently pull on the fender trim to release the (2) clips on each side. The clips should stay in the trim, if not the clip will need to be prying out of the fender and reconnected to the trim. Remove the two screws in both the inner fenders holding the under-light plastic trim panel on. Open the hood and remove the clips holding the top plastic panel on above the radiator. Gently pull the under-headlight panel outward, you may hear some pops from the clips releasing, the panel needs to be removed and set aside. Next remove the small bolts holding the lower portion of the grille on, these will be behind where the under-headlight trim panel was. After the small bolts are removed gently pull the grill outward, there may be some pops from the clips releasing. From under the vehicle, there will be a tubular looking side brace under both sides the bumper, remove the bolts holding the brace to the bumper and then the outer bolt holding the brace to the frame. The brace should be able to be pivoted to clear the bumper. Unplug any lights or wiring attaching the bumper to the truck. There will be (4) large silver bolts that hold the bumper to the frame, all 4 can be accessed through the top side of the bumper through where the grille was. The plastic tow hook pockets that are removable will require the bumper to be further disassembled to remove them.. Reinstall the bumper when finished with removing the tow hook bolt and/or the tow hook plastic pocket.
5. The driver side will use bracket #77749-7 and the passenger side will use bracket #77749-8. Place the bracket through the tow hook or trimmed opening in the bumper. The brackets will slide through the opening and under the bottom of the frame cradling it. Place (1) 1/2" x 1" bolt into the nut welded on the bottom side of the bracket. Only tighten the bolt enough so it does not protrude from the inside face of the brackets. Align the holes on bracket with holes in frame.
6. The nut plate brackets #77736-9 will be placed inside the frame to aid in bolting the brackets to the frame. The driver side nut plate needs to be aligned with the two holes in the side of the frame and bracket that face the center of the truck. The passenger side nut plate needs to be aligned with the two holes in the side of the frame and bracket that will be facing the outside of the truck.

Big Tex Grille Guard

Installation Instructions

77749 & 77749B

GMC Sierra 1500

2014 - 2017

7. Place (1) 1/2" lock washer and (1) 1/2" flat washer onto (4) 1/2" x 1 1/2" bolts. Thread each of the (4) bolts with washers through the side of the brackets and the frame and into the nut plates. Leave loose at this time. Place (1) flat washer each onto (2) 1/2" x 1 1/2" bolts and insert (1) bolt with washer into the outside hole on the driver side, going through the bracket and frame. Place (1) 1/2" flat washer, (1) 1/2" lock washer and (1) 1/2" nut onto the bolt from inside the frame. Insert (1) bolt with washer into the inside/center facing hole on the passenger side, going through the bracket and frame. Place (1) 1/2" flat washer, (1) 1/2" lock washer and (1) 1/2" nut onto the bolt from inside the frame. Tighten all (6) bracket side mounting bolts at this time. Installed driver side bracket #77749-7 is shown in **Diagram 2**.
8. Place (1) 1/2" lock washer and (1) 1/2" flat washer onto (8) of the 1/2" x 1 1/2" bolts. Align the grille guard uprights to the brackets installed on the truck. Insert and the (8) bolts with washers through the side holes in the uprights and threading into the brackets inside the uprights. Hand tighten at this time.
9. Assemble the uprights to the grille guard ring, using **Diagram 1** for reference. Each upright will get (2) 1/2" x 1 1/2" bolts, (2) 1/2" flat washers, (2) 1/2" lock washers that will go through the vertical plate on grille guard ring and thread into upright. Hand tighten all bolts at this time.
10. Tighten the bottom bolt on bracket until it is snug and there is no up or down movement with the grille guard and brackets. Do not over tighten the bottom bolt. Tighten all bolts attaching the grille guard to the brackets last.

Driver Side Brackets 77749-7 Installed



Diagram 2