



**2009-Current Ram 1500 Classic**  
**2010-Current Ram 2500/3500** (Classic & New Body)  
**No-Drill Front Rubber Mud Flap Set**  
**Mounting Diagram & Instructions**  
**Kit's # GCR31F / GCR32F**

**IMPORTANT:**

**Manufacturer is not responsible for negligent use of vehicle with mud flaps installed, including over-tightening of screws and bolts causing damage to vehicle or mud flaps.**



**TOOLS REQUIRED**

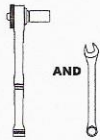

5/16 & 3/8" Open End Wrench & Socket Wrench

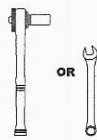

10mm open end or Socket Wrench

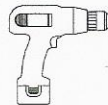

Electric or Chargeable 1/2" or 3/8" Drill



3/8" Socket Driver



1/4" Drill Bit

**FLAPS**

(1) Flap Assembly, Front, DS

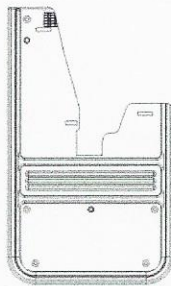

(1) Flap Assembly, Front, PS

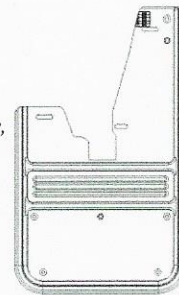

**PARTS BAG # 766126**

a) (8) Washer, Flat 0.203" x 1", SS Part #018081



b) (2) Washer, Lock #10, Helicoil, SS Part #024001



c) (2) Hex Nut #10, SS Part #025003



d) (2) Mach. Screw #10-24 x 1", SS Part #012022



**INSTALLATION** (For ease of installation it is suggested that the wheel be removed)

1. Before you install your Gatorback Mud Flap, see the diagram and parts list for all necessary parts.
2. Remove two (2) factory screws #4 & #5. Using the two (2) factory screws and included washers, reinstall on holes #1 & #2. Loosely secure at this point.
3. Square the flap with the tire, while putting pressure against the wheel well, then tighten the two (2) factory screws #4 & #5.
4. Hold flap tight against wheel well and drill 1/4" hole (1), from the center of the slotted hole #3 through the factory plastic liner. Secure the flap with one (1) machine screw #012022, two (2) flat washers #018031, one (1) lock washer #024001 and one (1) hex nut #025003.
5. Repeat procedure for passenger side.

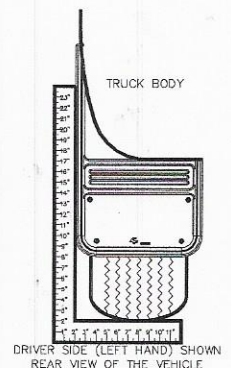

REMOVE THE FACTORY SCREWS AND REINSTALL THROUGH HOLES #1 AND #2

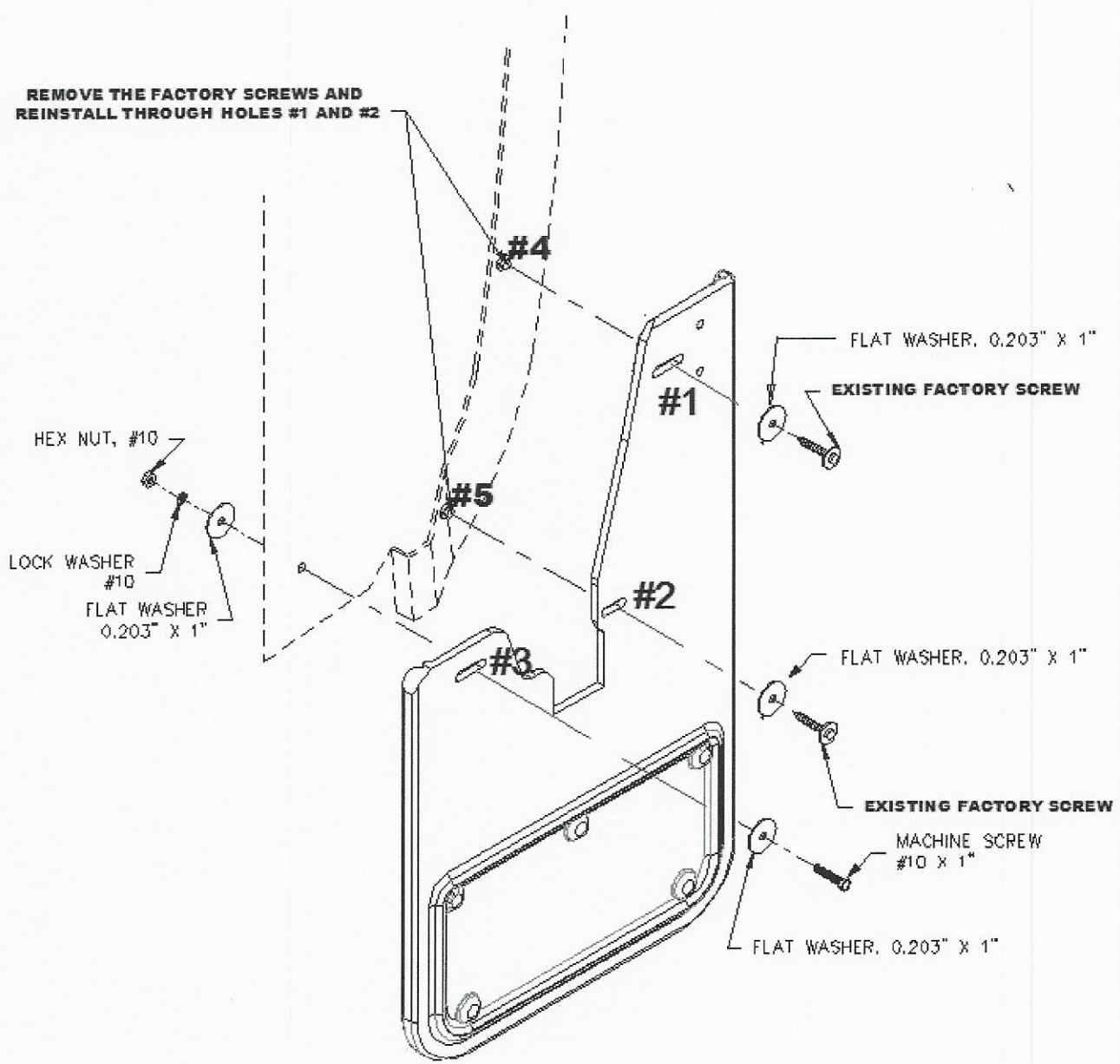

Please check out our YouTube channel to see an install video for this application.





# GATORBACK

## MUDFLAPS

**2010-2018, Ram HD Dually**  
**2019-Current, Ram HD Dually without flare**  
**Mud Flap Set**  
**Mounting Diagram & Instructions**  
**For use with 19" Rubber**  
**GB768068**

### IMPORTANT:

**The manufacturer is not responsible for negligent use of vehicle with mud flaps installed, including over-tightening of screws and bolts causing damage to vehicle or mud flaps.**

### TOOLS REQUIRED

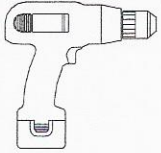

Electric or re-chargeable  
1/2" or 3/8" drill.



1/4  
drill bit

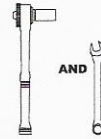

3/8" and 5/16" wrench  
and socket set



3/8" Socket Driver

### SCREWS / FASTENERS / WASHERS / FLAPS - PARTS BAG #768067

(1) SS Mount, DS  
Part #755530

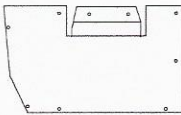

(1) SS Mount, PS  
Part #755531

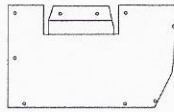

(1) Brkt, Z, DS  
Part #750433

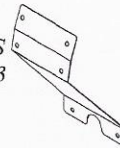

(1) Brkt, Z, PS  
Part #750434

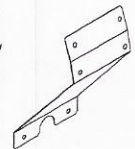

e) (44) Washer, Flat  
0.203" x 1" 18ga  
Part #018081



f) (20) Screw Machine  
#10-24UNC x 1-1/2  
Part #012027



c) (20) Nut, Hex, SS  
#10  
Part #025003



d) (20) Lock Washer  
#10  
Part #024001



Note: 2010-2018 Models require less hardware than 2019-2020 Models.  
If you are installing on a 2010-2018 Model, you will have extra hardware

**Prior to installation of your Mud Flap, see the above diagrams and parts list for all necessary parts.  
Start on the driver side.**

### INSTALLATION

*For ease of installation, it is suggested that the wheel be removed.*

- Align bracket to rubber (purchased separately) as shown in Diagram #1. Drill 1/4" holes into rubber through bracket holes. Cut rubber to match bracket profile.
- Remove factory harness mounts A & B with harness and reinstall to the "Z" bracket holes C & D.
- Bolt the upper holes of the "Z" bracket to the existing factory push screw holes A & B with two machine screws, four flat washers, two lock washers and two hex nuts.
- Remove the factory screws #11 & #12 on the wheel flare as shown on the diagram and reinstall the two factory screws, with flat washers, on holes #1 and #2 through the factory holes #11 and #12.
- Drill a 1/4" hole (7 places) from holes #3 to #9 through the factory tub liner then fasten holes #3 and #4 through the factory tub liner into the "Z" bracket bottom holes with two machine screws, four flat washers, two lock washers & two hex nuts. For the remaining holes, fasten with 5 machine screws, 10 flat washers, 5 lock washers, and 5 hex nuts.
- 5a. For 2019-2020 models, drill a 1/4" hole from the back lower corner of the factory plastic molding through the rubber flap to create hole #10, and then secure the flap using a machine screw, two flat washers, a lock washer, and a hex nut.

✓ **Check all fasteners for tightness. Repeat procedure on passenger side.**

**Diagram #1**

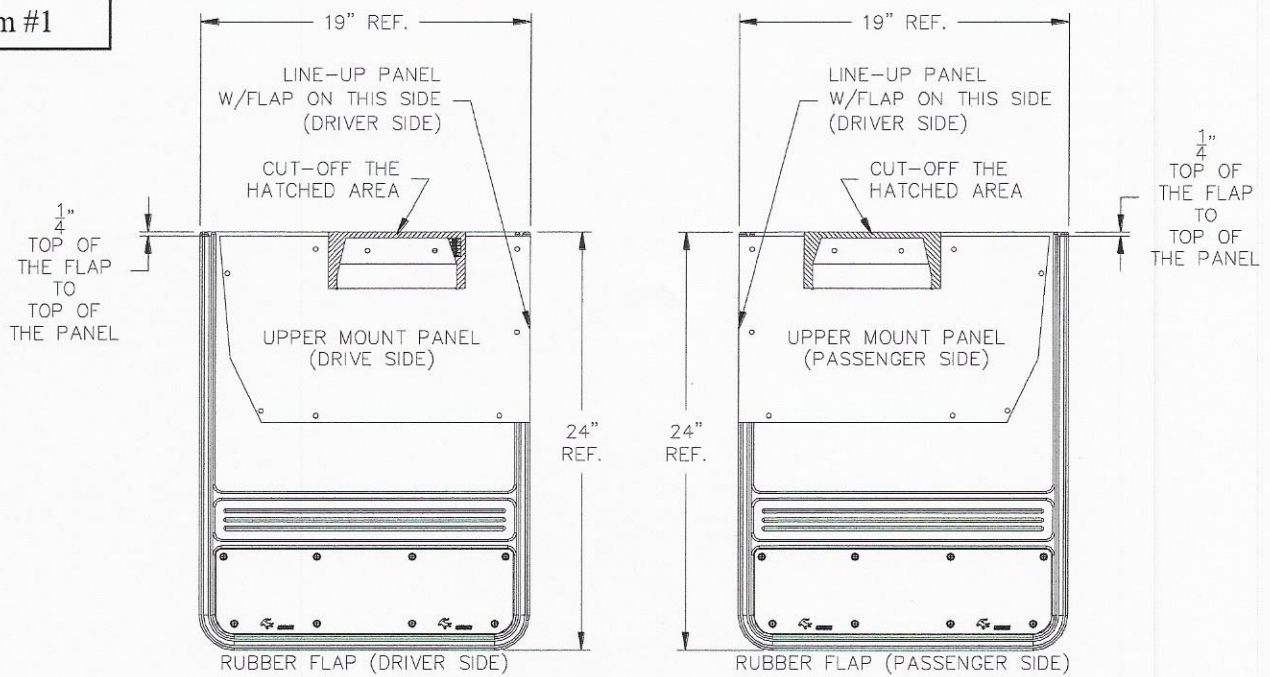

**Diagram #2**

