

Installation Instructions

I - Sheet Number BF139 Rev.-



Bugflector® - Bugflector II® - Carflector® - Chrome Hood Shield™

For proper installation and best possible fit, please read all instructions **BEFORE** you begin.
For technical assistance or to obtain missing parts, please call Customer Relations at 1-800-241-7219.

Important Safety Information



- CAUTION - Before driving, ensure that the hood shield is properly secured to vehicle.
- Do not use automatic "brush-style" car washes.
- Do not use cleaning solvents of any kind.
- Periodically check all components for tightness.

Contents

NOTE: Actual product may vary from illustration. Some applications will not require the use of all mounting hardware.

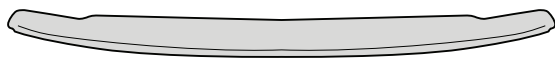

Hood shield



Alcohol pad x2



Self Tapping screw x2



Aluminium Flat Washer x2



Bump On x4
(98024)

Tools Required



Car Wash Supplies



Clean Towel

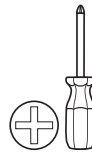

Phillips
screwdriver

Preparation Before Painting / Installation

- A trial fit is recommended to ensure proper positioning and fit.
- Check fit of parts before painting as we will not accept the return of modified or painted parts.
- Wash and dry your vehicle to remove any debris and/or dirt from the installation area.

Installation Steps

NOTE: Actual application may vary slightly from illustrations.

Open hood.

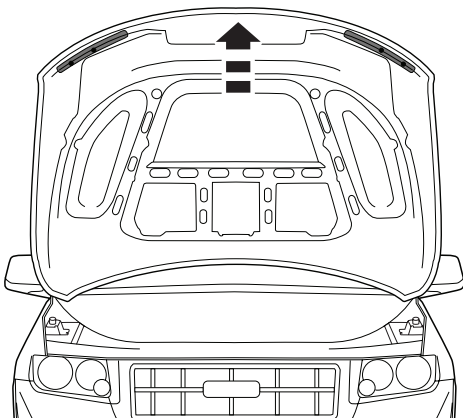

1

Remove (2) plastic seal retaining fasteners that align with the pre-drilled holes and flanges in the hood shield. Next, carefully separate the hood seal / gasket from the areas of the hood that align with the hood shield tabs.

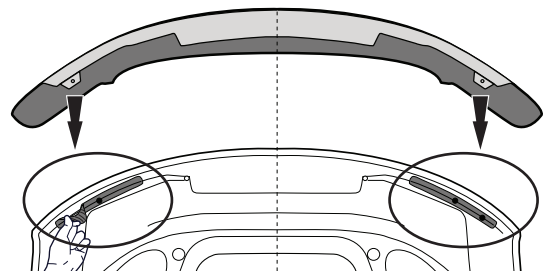

2



NOTE: Exercise extreme caution not to tear or damage the hood seal / gasket when separating from hood.

Installation Steps

NOTE: Actual application may vary slightly from illustrations.

Alcohol Pad

Use an alcohol pad to clean the hood surface that aligns with the center flange of the hood shield.

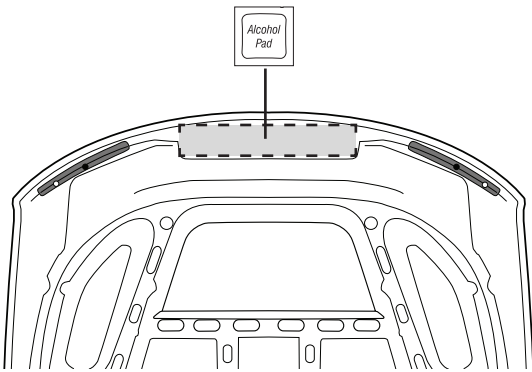

3

Peel back 2" of tape liner from one end of center flange to create a tape tab. Ensure tab is accessible.

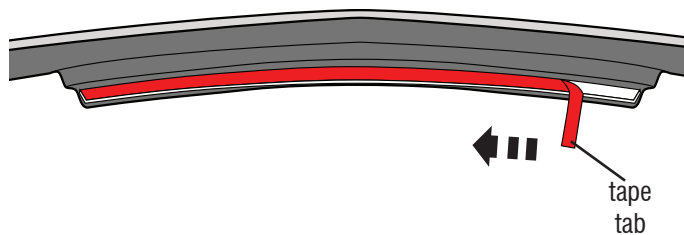

4

Center the hood shield on the hood.
Slide the OUTBOARD flanges between the hood and rubber seal and align with holes.

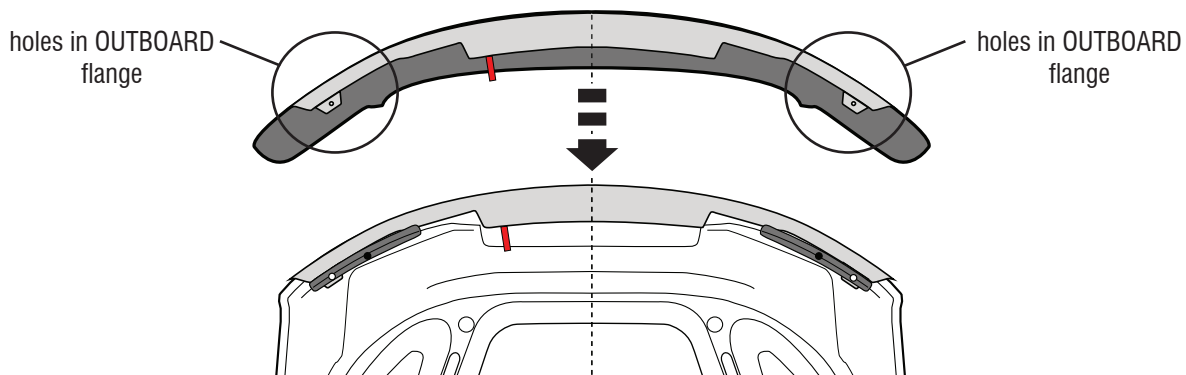

5



Insert (2) screws and washers through the rubber gasket, hood shield, and into the hood, at the OUTBOARD flange locations noted above. Securely tighten.

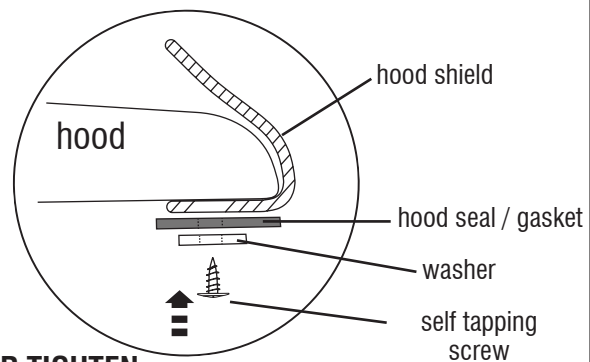
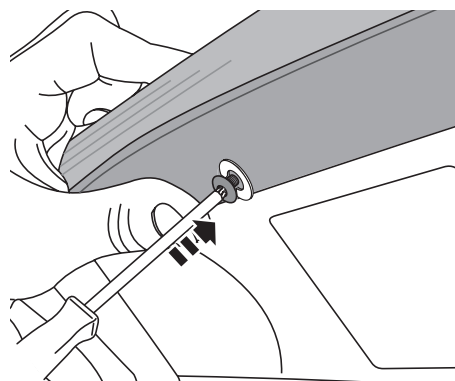

6

DO NOT OVER TIGHTEN

Remove remaining tape liner from the center flange.

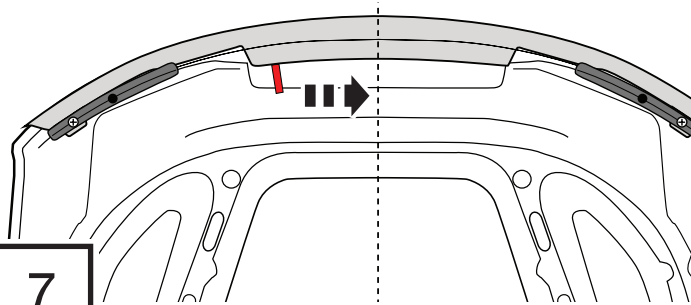

7

Apply firm pressure to center flange to ensure adhesion of tape to hood surface.

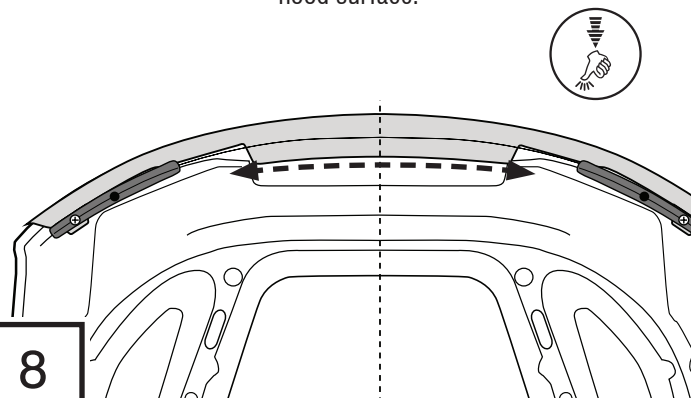

8

Installation Steps **NOTE:** Actual application may vary slightly from illustrations.

Turn both of the hood bumpers counter clockwise 1 1/2 turns.

Close Hood.

9

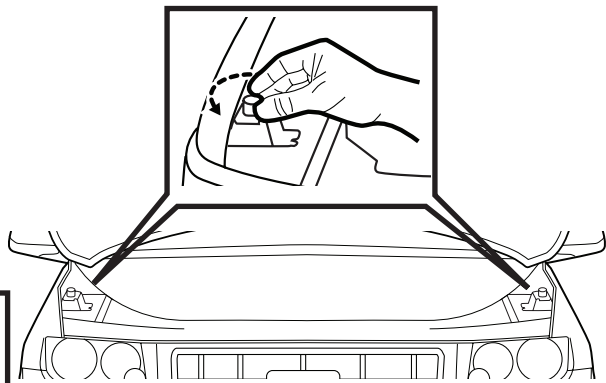

10

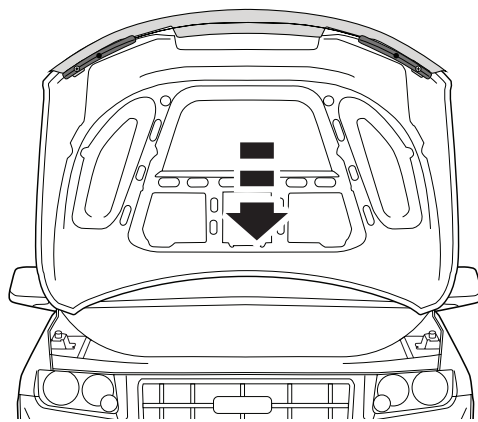

Apply (4) bump-ons to surface of hood.

11

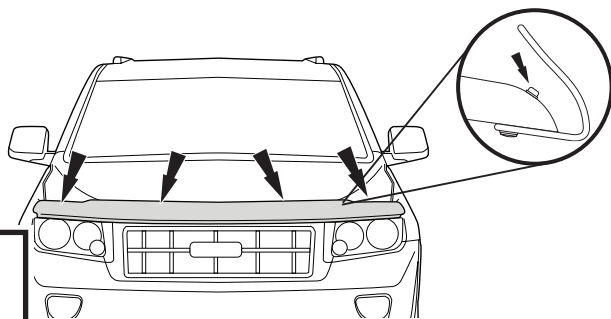

Care and Cleaning

- Wash only with mild soap & dry with a clean cloth.



The material that your product is made from can be recycled. Please also consider recycling the packaging that your product came in.



Congratulations!

You have purchased one of the many quality Auto Ventshade™ branded products offered by Lund International. We take the utmost pride in our products and want you to enjoy years of satisfaction from your investment. We have made every effort to ensure that your product is top quality in terms of fit, durability, finish and ease of installation.



Lund International

800-241-7219 • Visit us at lundinternational.com

© 2021 Lund, Inc. All rights reserved.

Auto Ventshade™, the Auto Ventshade™ logo and the AVS™ logo are trademarks of Lund, Inc.





Bugflector® - Bugflector II® - Carflector® - Chrome Hood Shield™

Pour une installation appropriée et le meilleur ajustement possible, veuillez lire l'ensemble des instructions **AVANT** de commencer.

Pour joindre l'assistance technique ou commander des pièces manquantes, veuillez appeler le service à la clientèle au 1 800 241-7219.

Informations importantes relatives à la sécurité



- MISE EN GARDE - Avant de conduire, vérifiez que la protection du capot est bien fixée au véhicule.
- N'utilisez pas de lave-auto à « brosses automatiques ».
- N'utilisez jamais de solvants, quels qu'ils soient.
- Vérifiez régulièrement que les composants sont bien fixés.

Table des matières

REMARQUE : Le produit livré peut différer de l'illustration. Certaines applications ne nécessitent pas l'utilisation de tout le matériel de montage.



Protection du capot



Tampons alcool x 2



Vis auto-taraudeuses x 2



Rondelle plate aluminium x 2



Gommes x 4
(98024)

Outils nécessaires



Fournitures de lavage auto



Chiffon propre

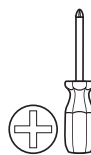

Tournevis cruciforme

Préparation avant la peinture / l'installation

- Effectuez d'abord un essai afin de vous assurer du positionnement et de l'ajustement du produit.
- Vérifiez l'ajustement des pièces avant de les peindre, car aucune pièce modifiée ou peinte ne pourra être retournée.
- Nettoyez et séchez le véhicule afin d'éliminer les débris ou les saletés de la zone de montage.

Étapes d'installation

REMARQUE : L'installation peut différer légèrement des illustrations.

Ouvrez le capot.

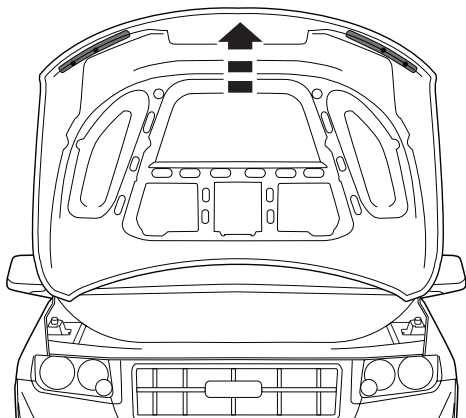

1

Retirez (2) les attaches de maintien du joint en plastique alignées avec les trous pré-perçés et les brides de la protection du capot. Ensuite, séparez soigneusement le joint / la rondelle du capot des sections du capot alignées avec les languettes de la protection du capot.

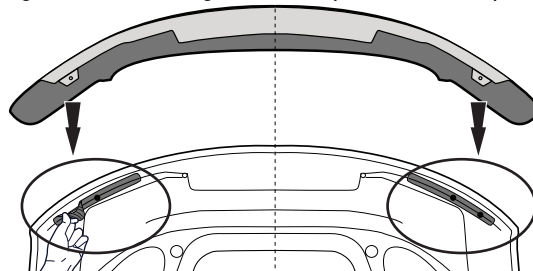

2



REMARQUE : Utilisez toutes les précautions nécessaires afin de ne pas déchirer ou briser le joint / la rondelle du capot lorsque vous le retirez du capot.

Étapes d'installation

REMARQUE : L'installation peut différer légèrement des illustrations.

TAMPON
d'alcool

Utilisez un tampon d'alcool pour nettoyer la surface du capot alignée avec la bride centrale de la protection du capot.

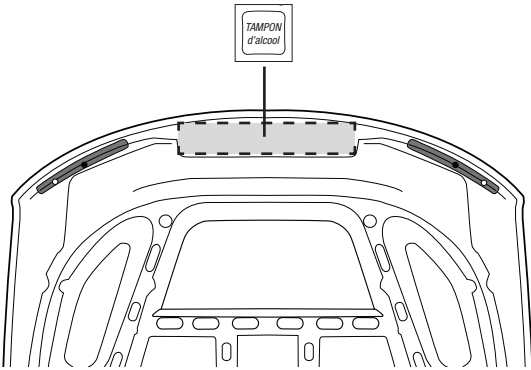

3

Retirez 2 pouces de la doublure du ruban d'une extrémité de la bande centrale pour créer une languette de ruban. Assurez-vous que la languette est accessible.

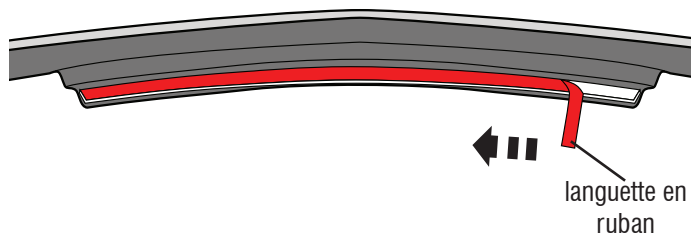

4

Centrez la protection du capot sur le capot.
Glissez les brides OUTBOARD entre le capot et le joint en caoutchouc et alignez avec les trous.

trous dans la bride
OUTBOARD

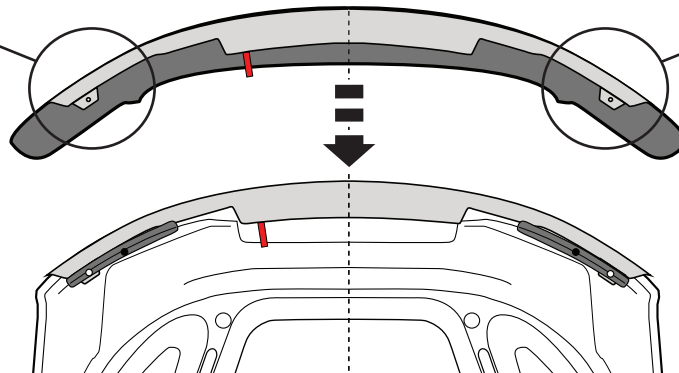

trous dans la bride
OUTBOARD

5

Insérez (2) vis et rondelles à travers la rondelle en caoutchouc, la protection du capot, et à l'intérieur du capot, aux emplacements des brides OUTBOARD indiqués ci-dessus. Serrez fermement.

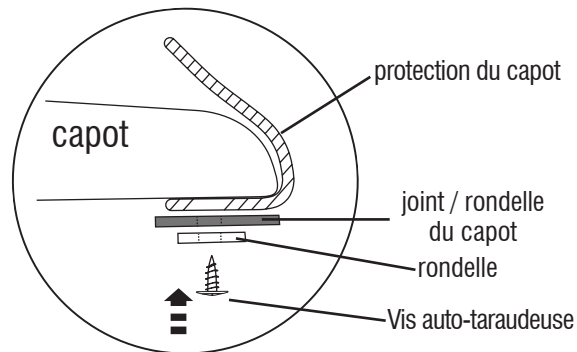
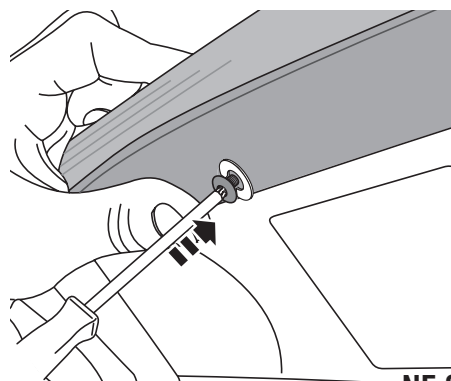
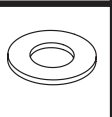

6

NE SERREZ PAS TROP LES VIS

Retirez la doublure de ruban restante de la bride centrale.

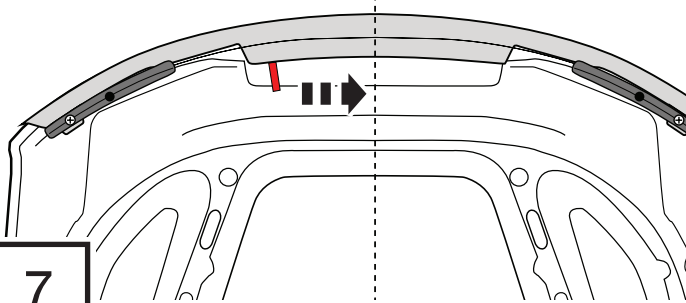

7

Appliquez fermement une pression sur la bride centrale afin de vous assurer de l'adhésion du ruban à la surface du capot.

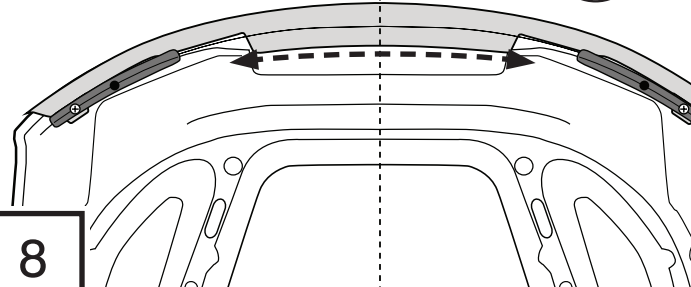

8

Étapes d'installation

REMARQUE : L'installation peut différer légèrement des illustrations.

Tournez de 1 tour et demi les deux butées du capot dans le sens anti-horaire.

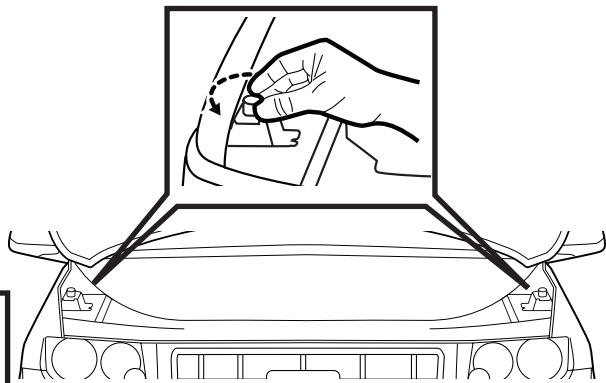

9

Fermez le capot.

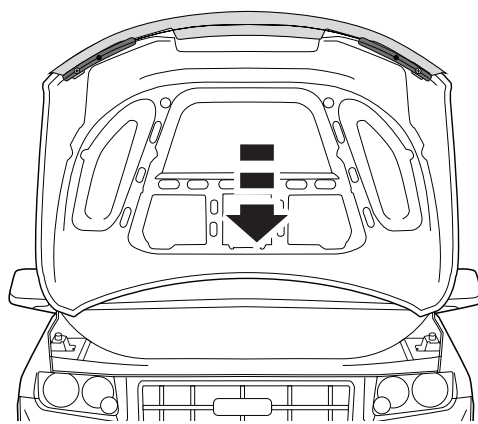

10

Placez (4) gommés sur la surface du capot.

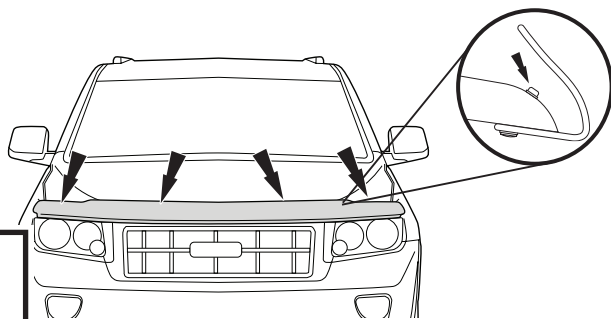

11

Entretien et nettoyage

- Lavez au savon doux uniquement et sécher avec un linge propre.



Les matériaux à partir desquels votre produit est fabriqué sont recyclables. Pensez également à recycler l'emballage dans lequel notre produit a été livré.



Félicitations !

Vous venez d'acheter l'un des nombreux produits de qualité de la marque Auto Ventshade™ fabriqués par Lund International. Nous sommes extrêmement fiers de nos produits et nous espérons que vous profiterez avec satisfaction de cet investissement de nombreuses années. Nous nous efforçons d'offrir la meilleure qualité en matière de précision, de durabilité, de finition et de simplicité d'installation.



Lund International

800-241-7219 • Visitez notre site lundinternational.com

© 2021 Lund, Inc. Tous droits réservés.

Auto Ventshade™, le logo Auto Ventshade™ et le logo AVS™ sont des marques déposées Lund, Inc.



Instrucciones de instalación

I - Número de hoja BF139 Rev.-



Bugflector® - Bugflector II® - Carflector® - Chrome Hood Shield™

Para lograr una instalación correcta y el mejor ajuste posible, lea todas las instrucciones ANTES de comenzar. Para pedir asistencia técnica u obtener piezas faltantes, llame a Atención al cliente al 1-800-241-7219.

Información de seguridad importante



- ADVERTENCIA: Antes de conducir, asegúrese de que la cubierta del capó esté debidamente asegurada al vehículo.
- No lave su vehículo en lavaderos automáticos que utilicen cepillos.
- No use ningún tipo de solvente de limpieza.
- Compruebe periódicamente que todos los componentes estén ajustados.

Contenido

NOTA: El producto real puede ser diferente al de la ilustración. Algunas aplicaciones no requerirán el uso de todo el hardware de montaje.



Cubierta del capó



Paños con alcohol x 2



Tornillo autorroscante x 2



Arandela plana de aluminio x 2



Topes x 4 (98024)

Herramientas necesarias



Suministros de limpieza de vehículos

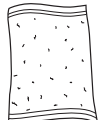

Toalla limpia



Destornillador Phillips

Preparación antes de pintar o instalar

- Se recomienda realizar un ajuste de prueba para garantizar el posicionamiento y el ajuste correctos.
- Verifique el ajuste de las piezas antes de pintarlas, ya que no se aceptará la devolución de piezas modificadas o pintadas.
- Lave y seque el vehículo para quitar cualquier desecho o suciedad del área de instalación.

Pasos para la instalación

NOTA: La aplicación real puede diferir levemente de las ilustraciones.

Abra el capó.

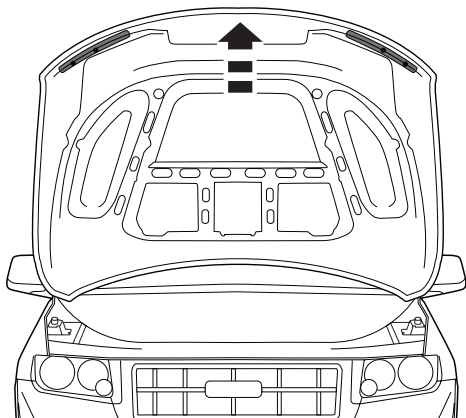

1

Quite los (2) sujetadores de retención del sello de plástico que se alinean con los orificios perforados previamente y los rebordes en la cubierta del capó. A continuación, separe con cuidado el sello/la junta del capó de las áreas del capó que se alinean con las lengüetas de la cubierta del capó.

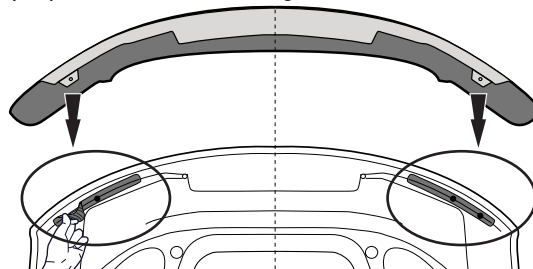

2



NOTA: Tenga mucho cuidado de no rasgar ni dañar el sello/la junta del capó al separarlo del capó.

Pasos para la instalación

NOTA: La aplicación real puede diferir levemente de las ilustraciones.

3 Use un paño con alcohol para limpiar la superficie del capó que se alinea con el reborde central de la cubierta del capó.

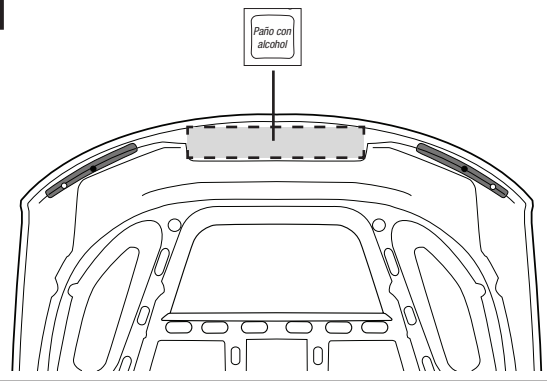

4 Retire 2 pulgadas de cinta protectora de un extremo del reborde central para crear una lengüeta de cinta. Asegúrese de que la lengüeta sea accesible.

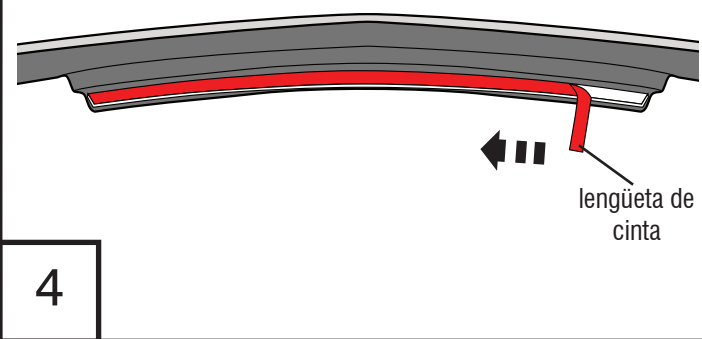

5 Centre la cubierta del capó en el capó.
Deslice los rebordes EXTERIORES entre el capó y el sello de goma y alinee con los orificios.

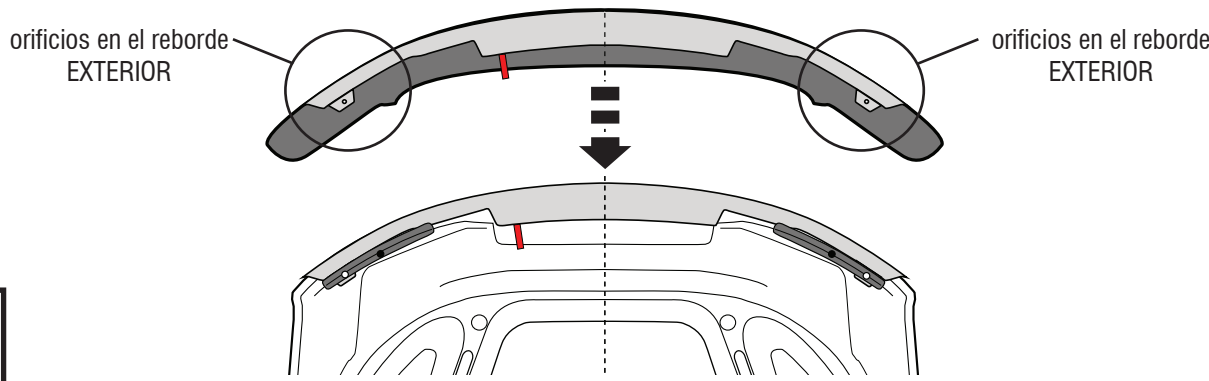

6 Inserte (2) tornillos y arandelas a través de la junta de goma, la cubierta del capó y dentro del capó, en las ubicaciones de los rebordes EXTERIORES indicadas anteriormente. Ajuste bien.

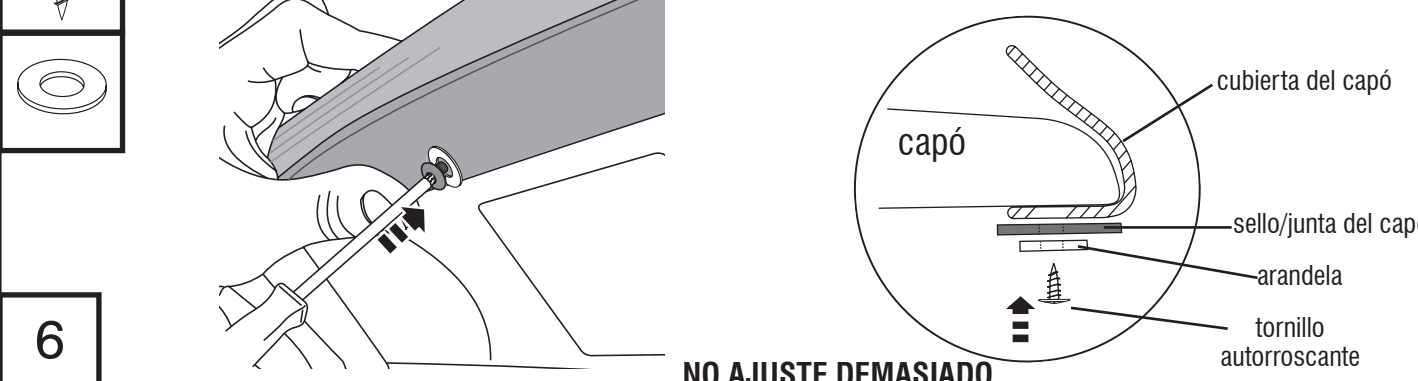

7 Quite la cinta protectora sobrante del reborde central.

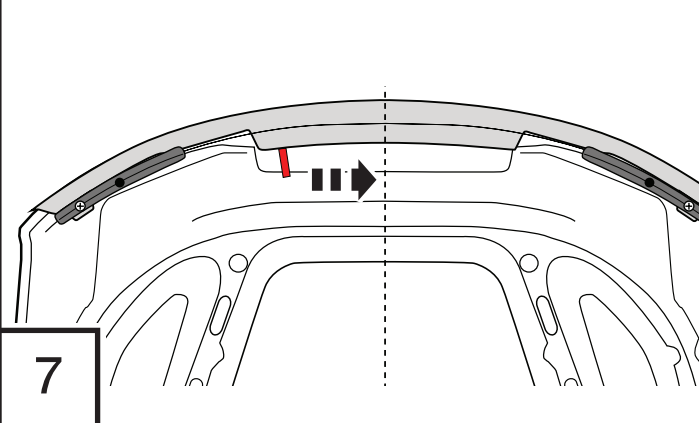

8 Aplique presión firme en el reborde central para asegurar la adhesión de la cinta a la superficie del capó.

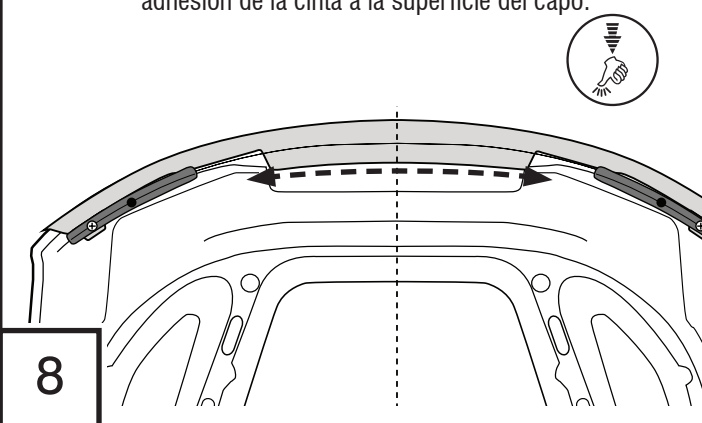

Pasos para la instalación

NOTA: La aplicación real puede diferir levemente de las ilustraciones.

Gire ambos topes del capó en sentido antihorario 1 vuelta y media.

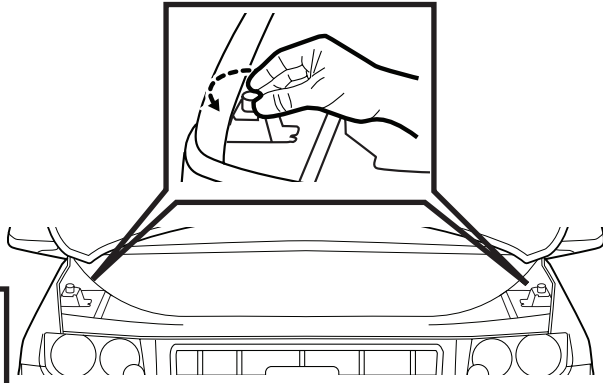

Cierre el capó.

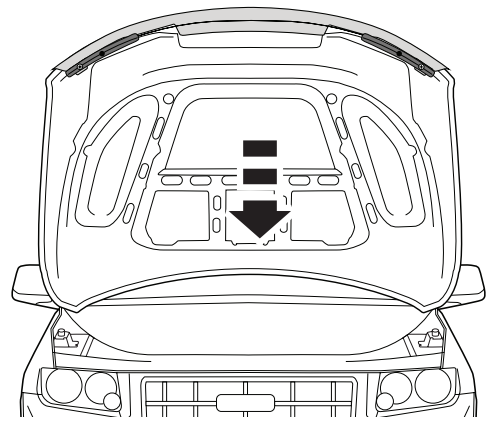

Aplique (4) topes a la superficie del capó.

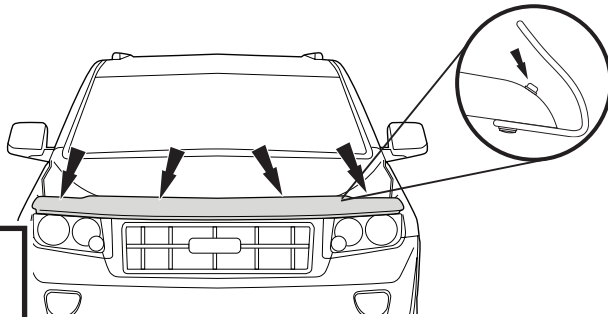

Cuidado y limpieza

- Lave solo con jabón suave y seque con un paño limpio.



El material del que está hecho el producto puede reciclarse. Considere también reciclar el embalaje en el que viene nuestro producto.



¡Felicitaciones!

Usted ha adquirido uno de los muchos productos de calidad de la marca Auto Ventshade™ que ofrece Lund International. Estamos muy orgullosos de nuestros productos y queremos que disfrute de años de satisfacción con su inversión. Nos hemos esforzado mucho para asegurarnos de que su producto sea de gran calidad en cuanto al ajuste, la durabilidad, el acabado y la facilidad de instalación.



Lund International

800-241-7219 • Visite nuestro sitio Web: lundinternational.com

© 2021 Lund, Inc. Todos los derechos reservados.

Auto Ventshade™, el logo de Auto Ventshade™ y el logo de AVS™ son marcas comerciales de Lund, Inc.

