

## INSTALLATION INSTRUCTIONS #INST002:

REALTRUCK BACKRACK KIT #30123, 30123TB, 30123TB31  
2015-2016 Ford F-150 Aluminum New Body

### READ THIS NOW!

Your truck should look like the one shown. If you think you are missing any parts, think that this part number is not for your truck or have any installation question, call our customer service department at toll free:

**888-588-6101 or locally 800-265-8137.**

**Other ways to reach RealTruck Backrack:**

**email: [info@backrack.ca](mailto:info@backrack.ca)**

**[Support@backrack.com](mailto:Support@backrack.com)**



The RealTruck Backrack is secured to your truck with a pair of "Stake Pocket Bolts" specifically designed for your make and model of truck. These bolts mount into each of the two front stake pockets. The RealTruck Backrack assembly sits on the bed rails of your truck and is secured to these Stake Pocket Bolts. If your truck has a BEDLINER we suggest you remove it to install the Stake Pocket Bolts

#### PARTS LIST FOR KIT #30123

PART	DESCRIPTION	QTY
RMB523P	Rear Mount Bracket Passenger	1
RMB523D	Rear Mount Bracket Driver	1
RP523D	523 Rail Plate Driver Side	1
RP523P	523 Rail Plate Passenger Side	1
<b>HARDWARE BAG523</b>		
INST002	Installation Instruction	1
FYZ014	1/2"-20 x 3.25" Carriage Bolt Grade 8	2
SBY523P	Stake Pocket Bolt Passenger	1
SBY523D	Stake Pocket Bolt Driver	1
FYZ009	1/2"-13 Hex Nut	2
FYZ010	1/2" Lock Washer	2
FYZ011	1/2" Flat Washer	4
FYZ008	1/2"-20 Nylon Hex Lock Nut	2
<b>HARDWARE BAG923</b>		
INST044	Installation Instruction	1
RPY512S	Spacer Plate	2
SF004	Foam Pad	2

#### PARTS LIST FOR KIT #30123TB, 30123TB31

PART	DESCRIPTION	QTY
TB523D	Toolbox Bracket Driver	1
TB523P	Toolbox Bracket Passenger	1
<b>OR</b>		
TB900D	Toolbox Bracket Driver	1
TB900P	Toolbox Bracket Passenger	1
<b>HARDWARE BAG523</b>		
INST002	Installation Instruction	1
FYZ014	1/2"-20 x 3.25" Carriage Bolt Grade 8	2
SBY523P	Stake Pocket Bolt Passenger	1
SBY523D	Stake Pocket Bolt Driver	1
FYZ009	1/2"-13 Hex Nut	2
FYZ010	1/2" Lock Washer	2
FYZ011	1/2" Flat Washer	4
FYZ008	1/2"-20 Nylon Hex Lock Nut	2
<b>HARDWARE BAG923</b>		
INST044	Installation Instruction	1
RPY512S	Spacer Plate	2
SF004	Foam Pad	2

**FOR MORE INFORMATION SCAN HERE!**



1a

For each stake pocket bolt (driver and passenger) install large washer over the 3/4" bolt end of stake pocket bolt, and through the slot on the truck bed. Install the 3/4" small steel washer, lock washer and nut. Leave assembly finger tight at this stage.

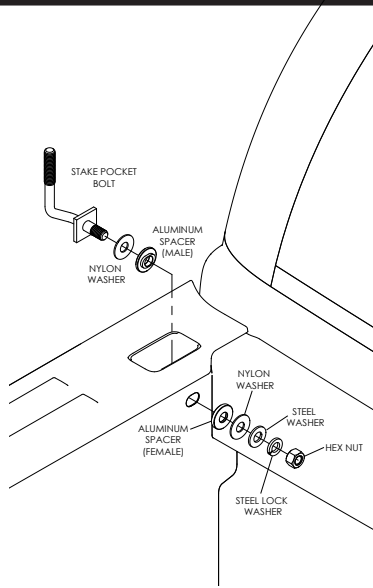

1b

Insert spacer plate over stake pocket bolt as shown, apply adhesive foam opposite to bolt clearance as shown

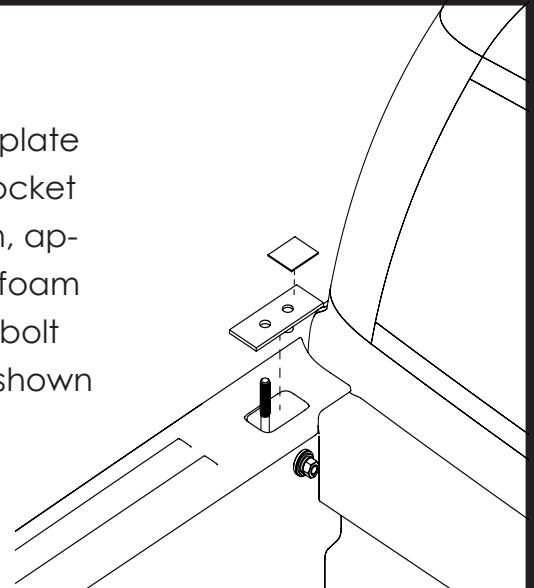

2

Fasten the RealTruck Backrack to the Rail mount bracket, or Toolbox bracket. Finger tighten at this stage.

**\*\*IMPORTANT\*\***

Install the carriage bolt as shown in the diagram with the round head closest to the cab. Failure to do so could result in damage to the cab or rear window.

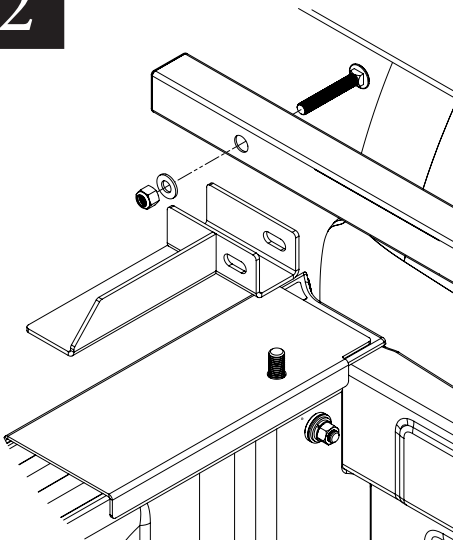

KIT #30123

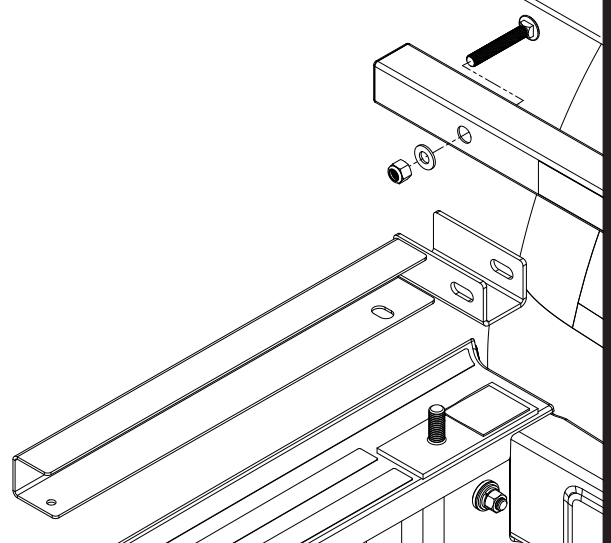

KIT #30123TB,  
30123TB31

3

Fasten RealTruck Backrack Assembly to the Stake pocket bolt as shown.

Center the RealTruck Backrack assembly on the truck and final torque all bolts starting with the nuts on the inside of the truck bed, then the rail mount or toolbox bracket and finally the main RealTruck Backrack carriage bolt

5/8" STEEL NUT,  
LOCK WASHER AND  
FLAT WASHER

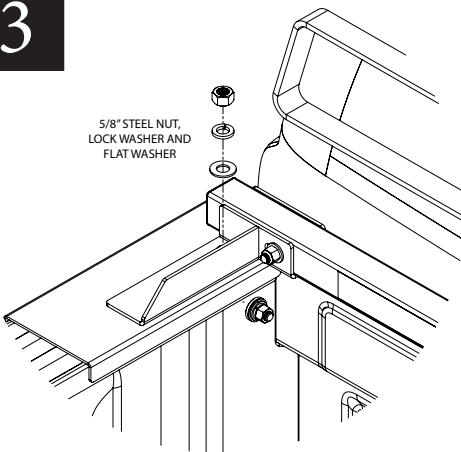

KIT #30123

5/8" STEEL NUT,  
LOCK WASHER AND  
FLAT WASHER

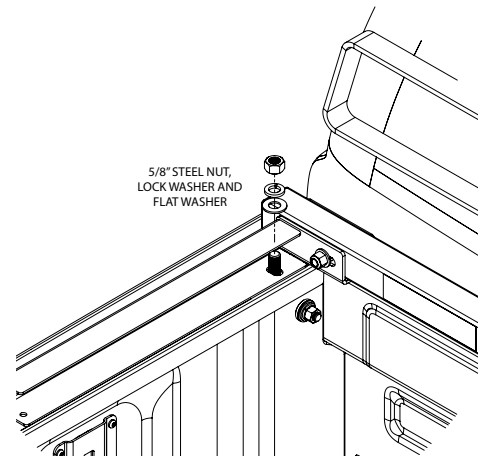

KIT #30123TB,  
30123TB31

**INSTALLATION INSTRUCTIONS #INST002:**  
**REALTRUCK BACKRACK KIT #30123, 30123TB, 30123TB31**  
2015-2016 Ford F-150 Aluminum New Body 5.5 FT BED  
SUPPLEMENTAL

1

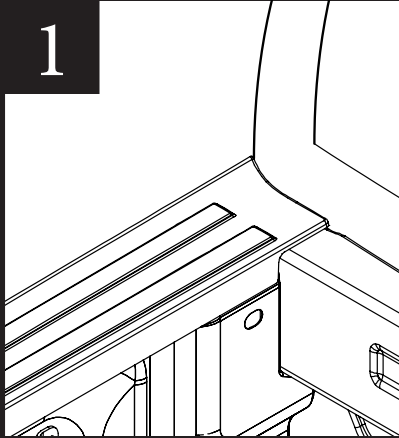

If your truck has a 5.5ft bed length, the rail trim cap covers the stake pocket opening, preventing the installation of the stake pocket bolt.

2

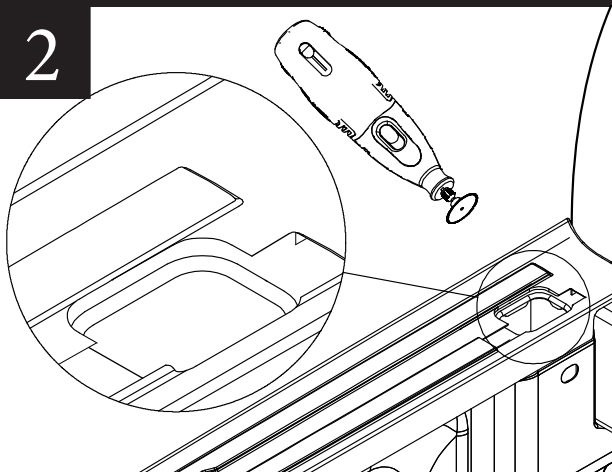

Using a rotary tool or a sharp utility knife, cut away the plastic cover to reveal the stake pocket. Cut away enough of the embossed area to allow for the locator shim to sit flush

3

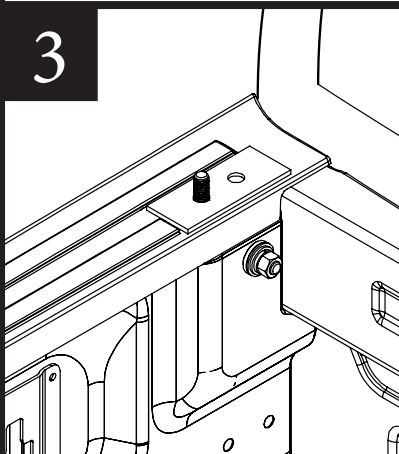

Install the stake pocket bolt as per instruction and install the locator shim as shown.

Continue with the installation as shown in the main instructions