

INSTALLATION INSTRUCTIONS : REALTRUCK BACKRACK KIT #30221, 30221TB, 30221TB31 2017- CURRENT SUPER DUTY ALUMINUM BODY

READ THIS NOW!

Your truck should look like the one shown. If you think you are missing any parts, think that this part number is not for your truck or have any installation question, call our customer service department at toll free:

888-588-6101 or locally 800-265-8137.

Other ways to reach RealTruck Backrack:

email: info@backrack.ca

Support@backrack.com



The RealTruck Backrack is secured to your truck with a pair of "Stake Pocket Bolts" specifically designed for your make and model of truck. These bolts mount into each of the two front stake pockets. The RealTruck Backrack assembly sits on the bed rails of your truck and is secured to these Stake Pocket Bolts. If your truck has a BEDLINER we suggest you remove it to install the Stake Pocket Bolts

PARTS LIST FOR KIT #30221

PART	DESCRIPTION	QTY
RP521D	RAIL PLATE DRIVER	1
RP521P	RAIL PLATE PASSENGER	1
RMB521D	RAIL MOUNT BRACKET DRIVER	1
RMB521P	RAIL MOUNT BRACKET PASSENGER	1
HARDWARE BAG521		
INST072	Installation Instruction	1
LAS125	SUPPORT CLIP	2
SF015	ADHESIVE RUBBER	4
SBY521D	STAKE POCKET BOLT DRIVER	1
SBY521P	STAKE POCKET BOLT PASSENGER	1
FW0404B	NYLON WASHER	4
AOV523	1/2" ALUMINUM WASHER MALE	2
ARD523	1/2" ALUMINUM WASHER FEMALE	2
FYZ016	5/8" NUT	2
FYZ017	5/8" LOCK WASHER	2
FYZ018	5/8" FLAT WASHER	2
FYZ009	1/2" NUT	2
FYZ010	1/2" LOCK WASHER	2
FYZ011	1/2" FLAT WASHER	4
FYZ014	1/2"-20 CARRIAGE BOLT (FINE THREAD)	2
FYZ008	1/2"-20 LOCK NUT (FINE THREAD)	2

PARTS LIST FOR KIT #30221TB, 30221TB31

PART	DESCRIPTION	QTY
TB521D(31)	TOOL BOX BRACKET (STANDARD OR 31") DRIVER	1
TB521P(31)	TOOL BOX BRACKET (STANDARD OR 31") PASSENGER	1
HARDWARE BAG521		
INST072	Installation Instruction	1
LAS125	SUPPORT CLIP	2
SF015	ADHESIVE RUBBER	4
SBY521D	STAKE POCKET BOLT DRIVER	1
SBY521P	STAKE POCKET BOLT PASSENGER	1
FW0404B	NYLON WASHER	4
AOV523	1/2" ALUMINUM WASHER MALE	2
ARD523	1/2" ALUMINUM WASHER FEMALE	2
FYZ016	5/8" NUT	2
FYZ017	5/8" LOCK WASHER	2
FYZ018	5/8" FLAT WASHER	2
FYZ009	1/2" NUT	2
FYZ010	1/2" LOCK WASHER	2
FYZ011	1/2" FLAT WASHER	4
FYZ014	1/2"-20 CARRIAGE BOLT (FINE THREAD)	2
FYZ008	1/2"-20 LOCK NUT (FINE THREAD)	2

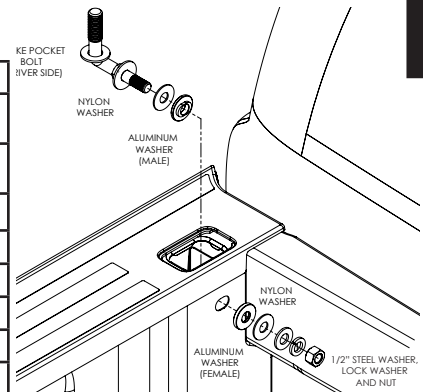

For each stake pocket bolt (driver and passenger) install nylon washer and aluminum washer over the rubberized end. Install the assembly into the stake pocket, and through the slot on the truck bed. Install the mating aluminum washer, nylon washer, 1/2" steel washer, lock washer and nut. Leave assembly finger tight at this stage.

FOR MORE INFORMATION SCAN HERE!



KIT #30221

Install adhesive rubber strips onto clip

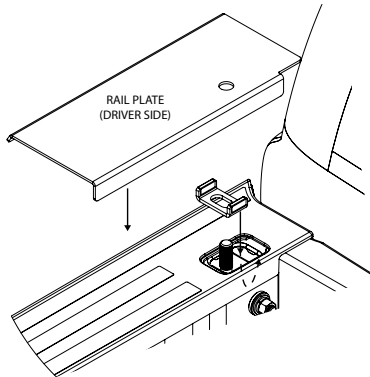
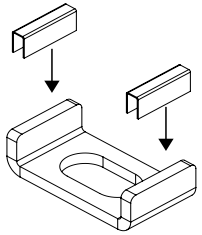

Insert support clip into stake bolt pocket and under the edges of the pocket opening

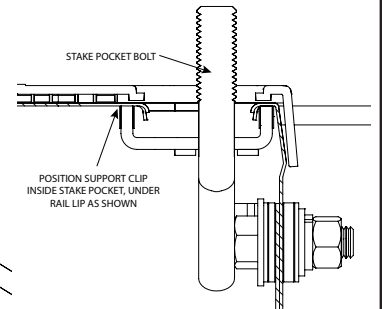
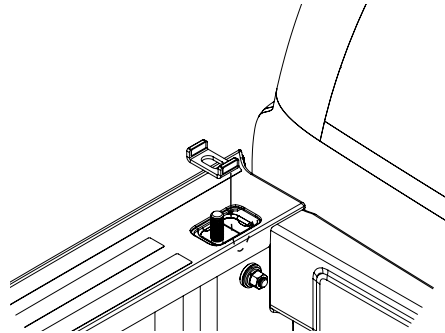

Cut away view showing support clip in correct position

For the 30221 kit place rail plate over the stake pocket bolt and position notch against the front of the bed as shown

KIT #30221TB,
30221TB31

2

Fasten the RealTruck Backrack to the Rail mount bracket, or Toolbox bracket. Finger tighten at this stage.

****IMPORTANT****
Install the carriage bolt as shown in the diagram with the round head closest to the cab. Failure to do so could result in damage to the cab or rear window.

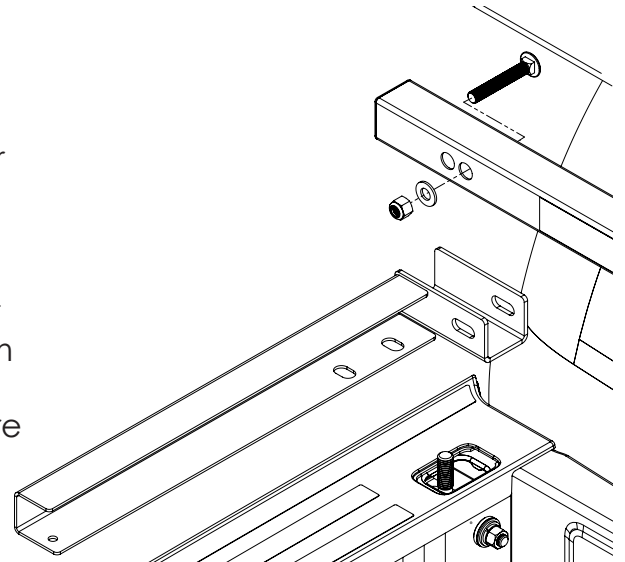
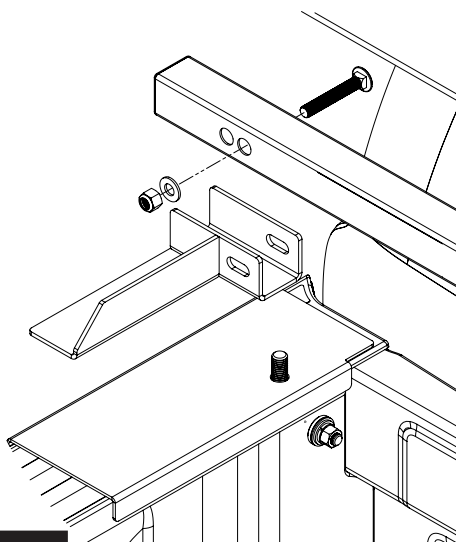

KIT #30221TB,
30221TB31

3

KIT #30221

Fasten the RealTruck Backrack Assembly to the Stake pocket bolt as shown.

Center the RealTruck Backrack assembly on the truck and final torque all bolts starting with the nuts on the inside of the truck bed, then the rail mount or toolbox bracket and finally the main RealTruck Backrack carriage bolt

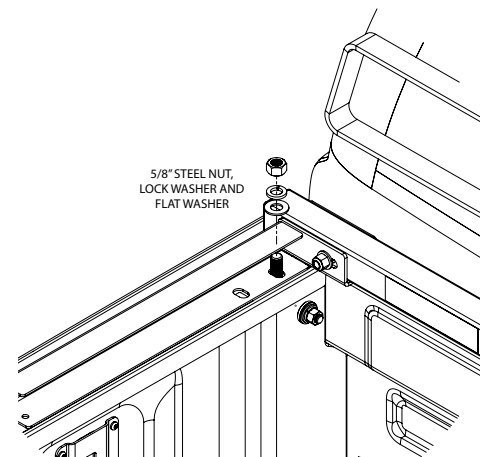
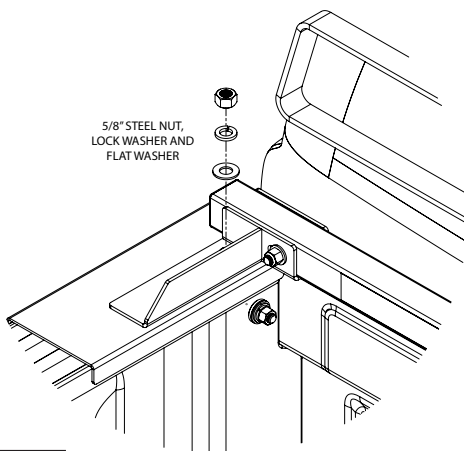

KIT #30221TB,
30211TB31

4

KIT #30221