



INSTALLATION INSTRUCTIONS : BED COVER ADAPTER #INST221

#50327 2005-2015 Toyota Tacoma with Uni-Track

2016-Current Toyota Tacoma 5' and 6' Box, MAX BED COVER WIDTH 62.5"

READ THIS NOW!

Your truck should look like the one shown. If you think you are missing any parts, think that this part number is not for your truck or have any installation question, call our customer service department at toll free:

888-588-6101 or locally 800-265-8137.

Other ways to reach RealTruck Backrack:

email: info@backrack.ca

Support@backrack.com



IMPORTANT!

The **RealTruck Backrack** is secured to your truck with a pair of "Stake Pocket Bolts" specifically designed for your make and model of truck. These bolts mount into each of the two front stake pockets. The **RealTruck Backrack** assembly sits on the bed rails of your truck and is secured to these Stake Pocket Bolts. If your truck has a BEDLINER we suggest you remove it to install the Stake Pocket Bolts.

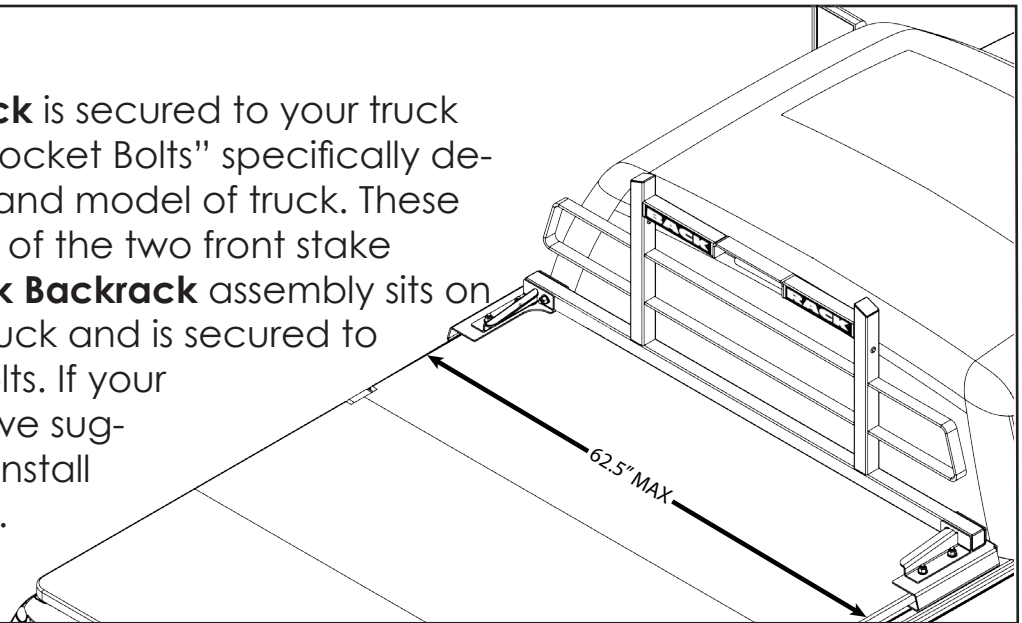

READ THIS BEFORE INSTALLATION !

RealTruck Backrack Inc is not affiliated with any Tonneau manufacturers products that are used in conjunction with RealTruck Backrack products. RealTruck Backrack Inc assumes no responsibility for any warranty offered by the Tonneau manufacturer and is not responsible in any way for any warranty claims or damages that may be made in relation to the Tonneau Cover. The Tonneau Cover manufacturer will have supplied a strap or fastening device designed to secure the cover in place when the cover is in an open position. Failure to secure the cover can result in personal injury or damage. RealTruck Backrack Inc has supplied a strap that is enclosed in this package. In the event that the strap or fastening device clip that was supplied with your Tonneau Cover is impeded or, in any way insufficient in its ability to secure the Tonneau in an open position after the installation of our RealTruck Backrack products, it is solely your responsibility to attach the strap that is supplied in this pack-age for the purpose of securing the Tonneau Cover in an open position. The enclosed strap provides sufficient length to loop around the RealTruck Backrack Cab Guard Frame and latch the Tonneau Cover securely and safely. You may be required to remove the Tonneau man-ufacturers supplied strap and replace it with the supplied longer strap. It is solely your responsibility to ensure that the strap is secured sufficiently and safely. RealTruck Backrack Inc is not responsible for any harm, damage, injury or claim that may result from this installation. By installing this product on your truck you assume complete responsibility for it's safe installation and forfeit RealTruck Backrack Inc from any liability claim or damages.

FOR MORE INFORMATION SCAN HERE!



1

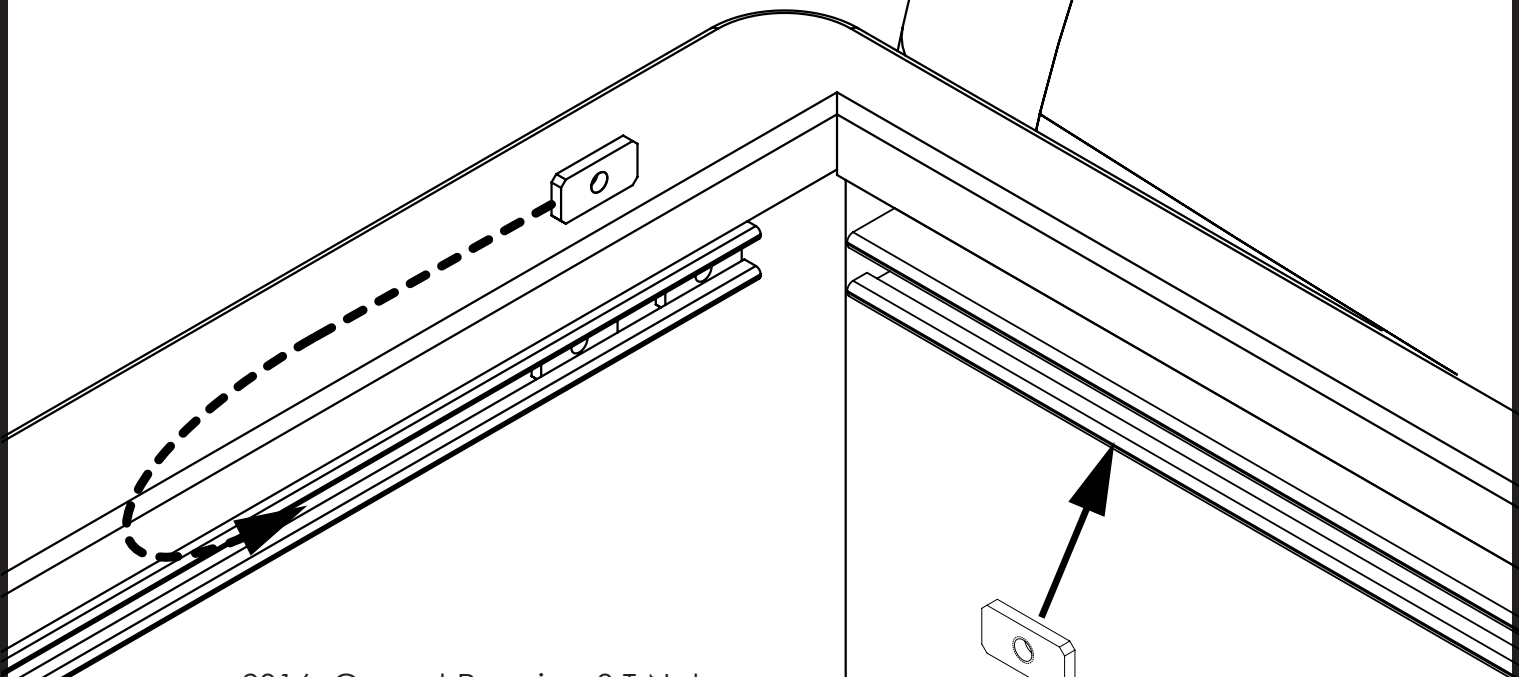
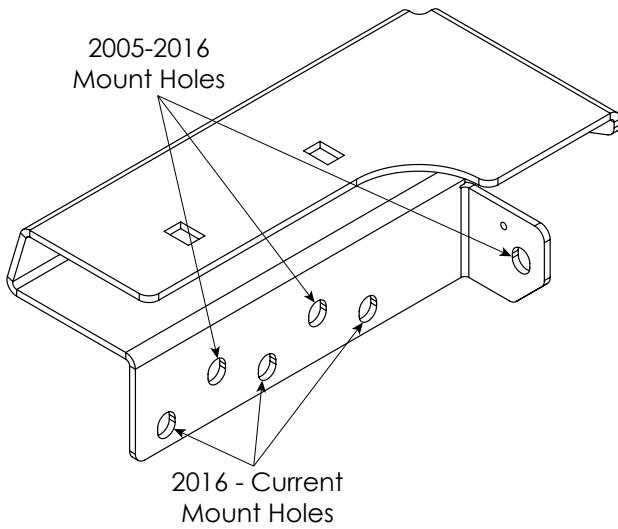

- 2016- Current Requires 3 T-Nuts per Side
- 2005-2015 Requires 2 T-Nuts per side and 1 T-Nut in the front rail per side
- Insert T-Nuts into the rail "C" channel on your truck
- Space approximately the same as on the adapter bracket

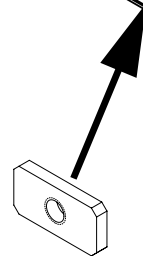

2005-2015 Models Only

2

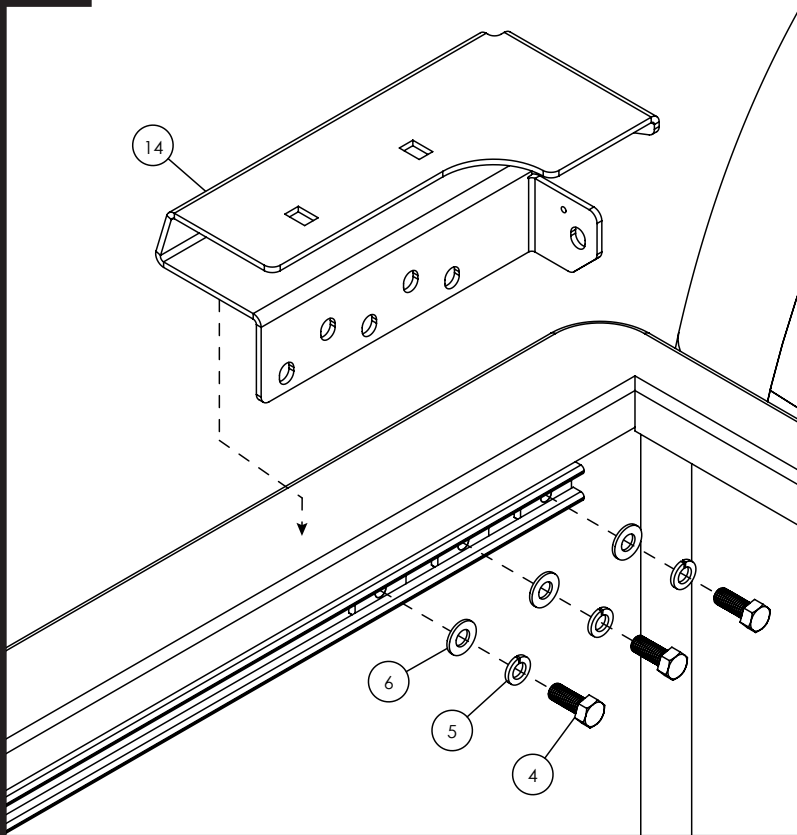

- Install tonneau adapter bracket #2
- Align T-nuts with bolt holes on adapter bracket
- Position bracket forward and against inside rail.
- Install Bolt #7, lock washer #8 and washer #9 (X3 per side)
- Snug bolts #7
- Snug bolts #7 to secure rear bolt.

3

- Install adhesive rubber strips on driver side bracket #16 and passenger side bracket #17
- Install brackets #16, 17* (*passenger side) onto RealTruck Backrack.
- Insert bolts #12 ****IMPORTANT: install bolts as shown to avoid damage to truck cab, rounded head towards window, threads to the rear of truck****
- Install washer #6 and lock nut #8 ****IMPORTANT: the main BACKRACK mount bolt (#12) is a fine threaded bolt, ensure that the nut threads easily****. Leave loose, finished torque will apply in final step.

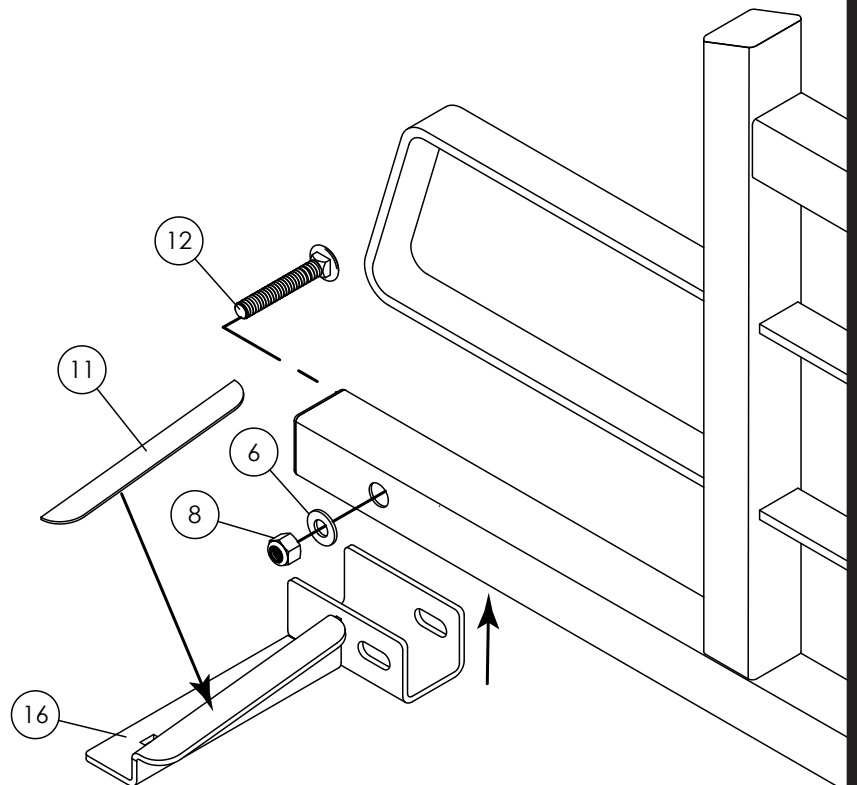

4



****CAUTION 2 PEOPLE ARE REQUIRED FOR THIS STEP****

- Place RealTruck Backrack assembly from step 3 onto brackets (two people required for lift and positioning)
- Center **RealTruck Backrack** assembly on truck, using top rear brake light as a visual guide.
- Install (4x) 1/2"-13 x 1.25" as shown.
- Snug down all nuts to bolts.
- Final torque nuts **A** (4x) to 70 ft/lbs.
- Final torque nut **B** (2x) to 60 ft/lbs.
- Final torque nut **C** (2x) to 30 ft/lbs. (Until lock washer flat)

IMPORTANT: ON A MONTHLY BASIS CHECK ALL FASTENERS FOR CORRECT TORQUE

Please Note: Stake pocket bolts may not be exactly as shown on this instruction, depending on the year make and model of your truck.

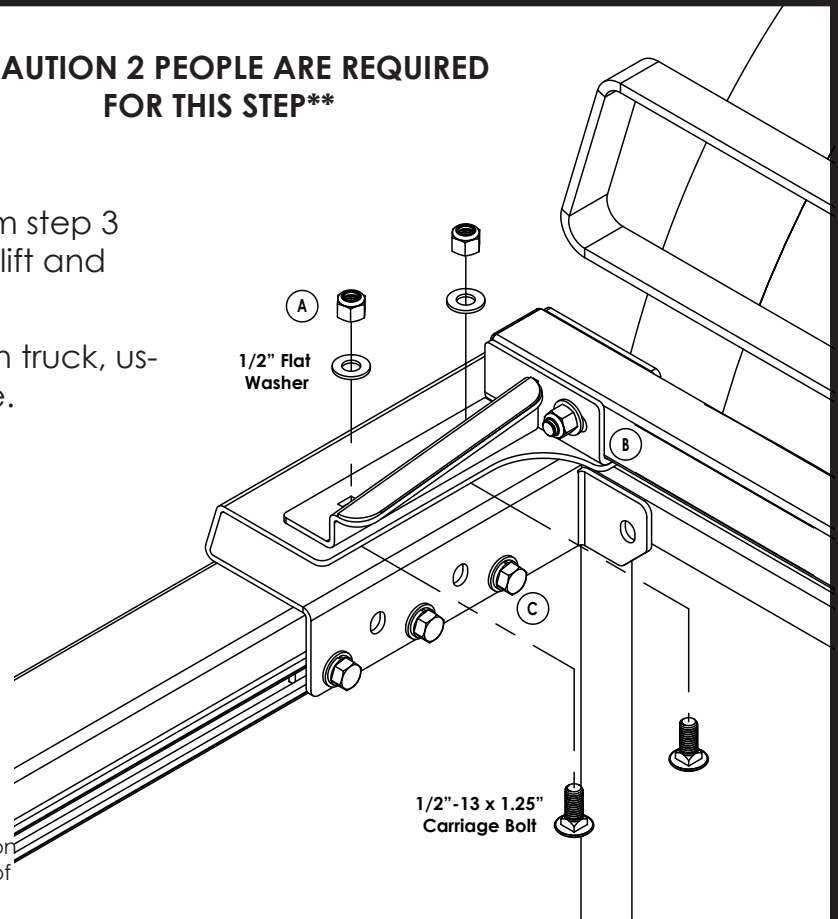

****Use supplied strap only when the original bed cover manufacture strap will not work
Cover must be secured in the open position in order to prevent wind damage to vehicle and or cover. Use of this alternate strap may void the warranty from the cover manufacturer. Check with cover supplier for further information****

- Loop strap around bottom tube of RealTruck Backrack.
- Snug strap using strap slide.
- Feed strap through existing strap loop on your bed cover.
- Feed Strap trough quick tight buckle and tighten.

OPTIONAL REAR CLIP:

In some bed cover applications, the optional rear clip is required. To determine if the rear clip is required for your application, measure the mount point on your cover to ensure you will be able to clamp without interfering with the adapter bracket assembly.

