

FTI-HDK2 Type 1A3 - Vehicle Coverage & Preparation Notes

Make	Model	Year	Install	CAN	Lights	RAP	Trunk	I/O Changes
DL-HA3					Park / Auto			Green White/Blue
Acura	TL STD Key	2009-14	Type 1	IMMO	gray/pink			
Acura	TSX STD Key	2009-14	Type 1	IMMO	*gray/pink *white/red			
Acura	ZDX STD Key	2010-11	Type 1	IMMO	*gray/pink *white/red			
Honda	Accord Crosstour STD Key	2010-12	Type 1	IMMO	*gray/pink *white/red			
Honda	Accord STD Key	2008-12	Type 1	IMMO	*gray/pink *white/red			
Honda	Odyssey STD Key	2011-17	Type 1	IMMO	gray/org			
Honda	Pilot STD Key	2009-15	Type 1	IMMO	gray/org			

Hey! Read this stuff before you start the installation...

Firmware:

Covered vehicles use **BLADE-AL(DL)-HA3** firmware, flash module and update the controller firmware before installing.

Install:

Type 1 vehicles use the **green 7-pin** immobilizer adapter, the gray adapter and the 8-pin CN1 adapter are not required. The covered vehicles require use of the 20-pin BLADE connector marked **HA3**, the connector marked **HA6** is not required and should be secured for safety.

Lights:

(-) Parking lights and Auto-light shutoff require additional wiring and direct connection from the CM I/O connector to the headlight switch connector, as illustrated. Known wire colors and common alternates are included in the list above.

Okay, now get to work...

- FT-DAS Required for manual transmission.
- BOTH Red & Red/White MUST be connected with high current application.

Jumper Setting					
Parking Light	<input type="checkbox"/>	<input type="checkbox"/>	<input type="checkbox"/>	<input type="checkbox"/>	(+)Door Trigger In
Accessory	<input type="checkbox"/>	<input type="checkbox"/>	<input type="checkbox"/>	<input type="checkbox"/>	(-)Door Trigger In (Default)
Ignition (Default)	<input type="checkbox"/>	<input type="checkbox"/>	<input type="checkbox"/>	<input type="checkbox"/>	
Trunk	<input type="checkbox"/>	<input type="checkbox"/>	<input type="checkbox"/>	<input type="checkbox"/>	Starter
Starter	<input type="checkbox"/>	<input type="checkbox"/>	<input type="checkbox"/>	<input type="checkbox"/>	Ignition
Parking Light (Default)	<input type="checkbox"/>	<input type="checkbox"/>	<input type="checkbox"/>	<input type="checkbox"/>	Accessory (Default)

CM7000/7200

CM-900S/900AS

CM900AS/900S Jumper

START
ACC
IGN1



FTI-HDK2 Type 1A3 - Installation Notes & Wiring Diagram

- A** Harness covers both HA3 and HA6 applications, the BLADE connector is the same for both firmware applications and harness configurations including those requiring use of ADPT B.
- B** HDK2 harness provides multiple immobilizer/parking light connections, this install type uses the **green** **Type 1** immobilizer connector as illustrated
- C** **Type 1** installations **DO NOT** require use of the included CN1 adapter. Please note, Types 1 & 2 have different ACC, IGN, and START circuit locations, proper programming and operation depend on using the correct CN1 configuration.
- D** (+) Parking lights are provided for convenience, (-) parking lights and GWR for Auto-light off are available in the CM I/O connector. **Type A** parking lights pin #11, auto-lights off pin #9, colors vary by model, but pin positions remain constant.

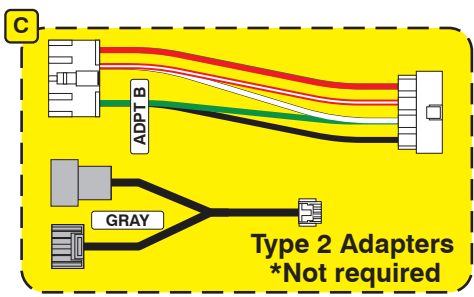
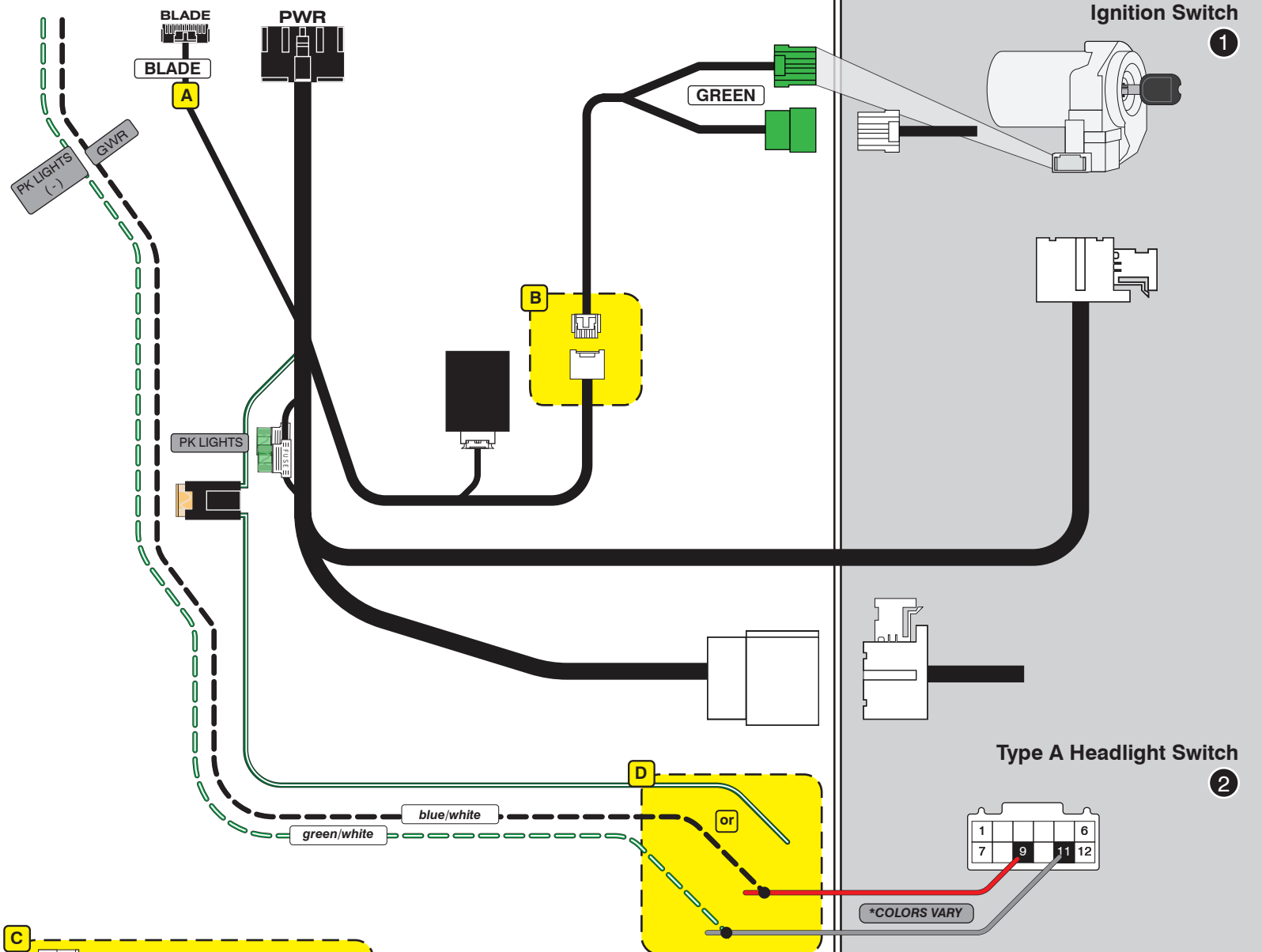
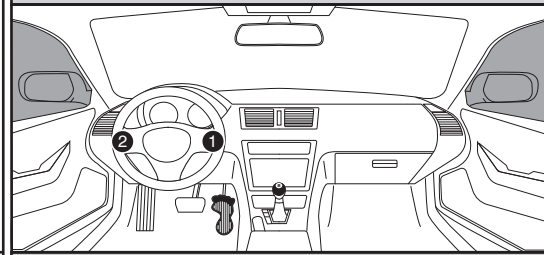

Module Programming Procedure

- Step 1 - Insert key into cylinder
- Step 2 - Activate IGN
- Step 3 - Wait for module LED to go solid blue
- Step 4 - Deactivate IGN
- Step 5 - Press unlock on OEM remote, programming complete

LED Programming Error Codes

- Module LED flashing RED during programming
- 1x - CAN error, confirm connections to immobilizer location

