

IMPORTANT:

Manufacturer is not responsible for negligent use of vehicle with mud flaps installed, including over-tightening of screws and bolts causing damage to vehicle or mud flaps.

TOOLS REQUIRED-

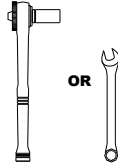

7mm Open Wrench or
Socket Wrench

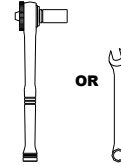

10mm Open Wrench or
Socket Wrench

FLAPS & BRACKETS

(1) Flap Assembly,
Front, DS

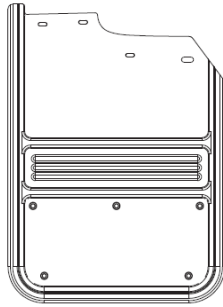

(1) Flap Assembly
Front, PS

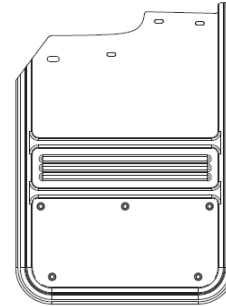

Brace, DS
Front
Part #759953

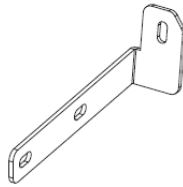

Brace, PS
Front
Part #759954

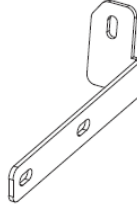

(2) Washer Plate
Front
Part #759955

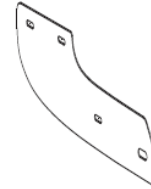

PARTS BAG #766179

a) (2) Hex Bolt, SS
M6, x 35mm, 18-8
Part #012028

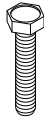

c) (2) Washer, Flat
0.281" x 1", Alum.
Part #018052

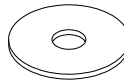

d) (8) Washer, Flat
0.265" x 0.625" Nylon
Part #054071

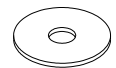

e) (2) Washer, Lock
1/4" Helicoil, SS
Part #024000



f) (2) Nut, Hex
M6 - 1, SS
Part # 025022



g) (4) Serrated Flange Nut
M6 - 1, Plated
Part # 025025



INSTALLATION *(For ease of installation it is suggested that the wheel be removed)*

1. Before you install your Mud Flap Set, see the diagram and parts list for all necessary parts.
2. Remove the (4) factory screws and (1) factory push pin on the inside and bottom of the fender and remove the factory splash guard. Now, reinstall the factory screw and push pin in the bottom of the fender.
3. Loosely install mud flap through the washer plate into factory holes using the factory screws and nylon washers (054071)
4. Loosely install the brace to the existing factory lower fender bolts using the supplied serrated flange nuts.
5. Loosely install mud flap to brace using a hex bolt (012028) and flat washer (018052) and secure using a flat washer (018052), lock washer (024000), and hex nut (025022).
6. Using a square or other leveling tool, ensure that the mud flap is level. Adjust the forward-back position of the brace so that the mud flap is approximately parallel to the tire tread. Tighten all fasteners.
7. Repeat procedure on the passenger side.

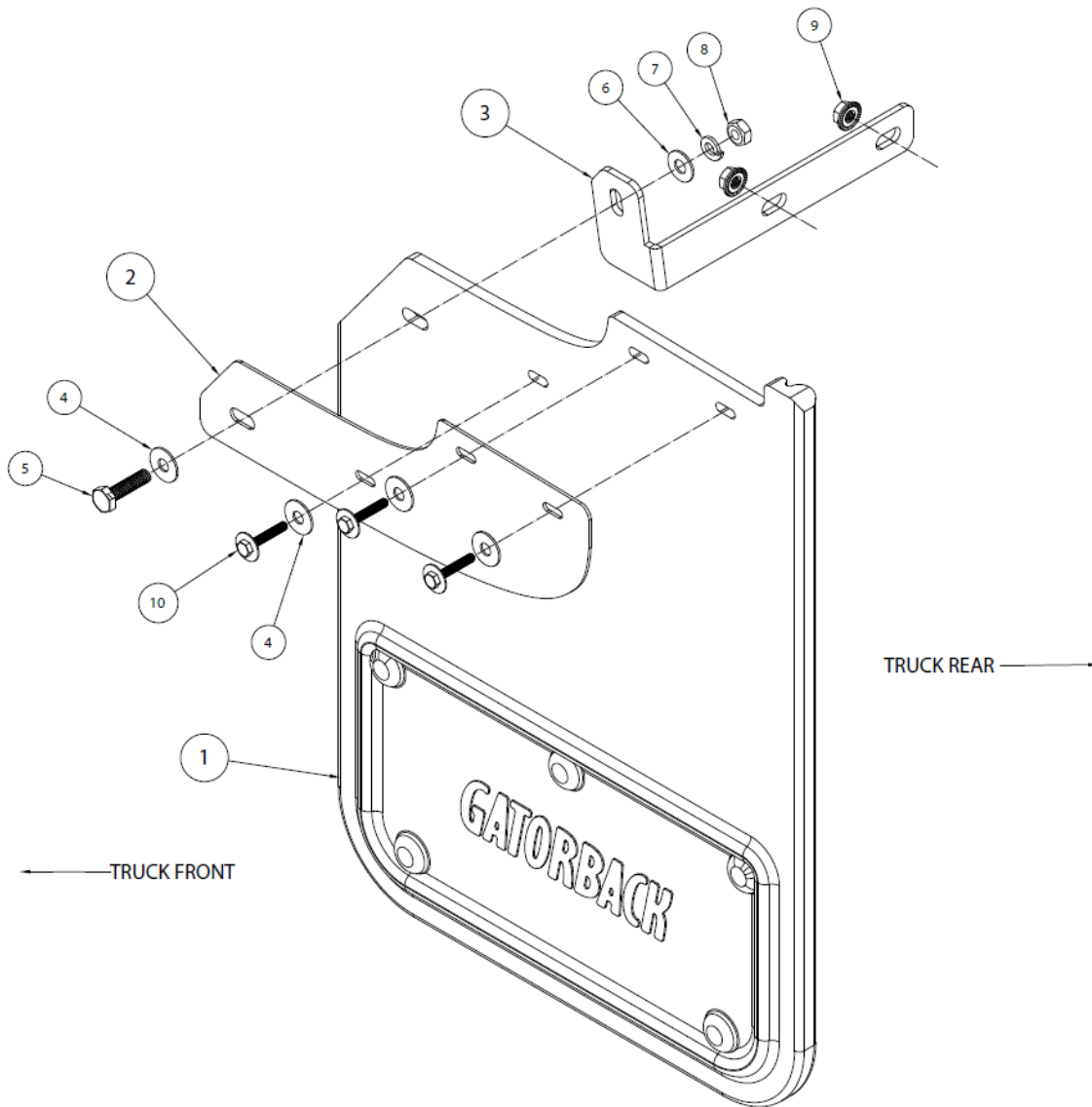

Please check out our YouTube channel to see an install video for this application

