

APPLICATION

Ford Super Duty 2017
F-250/350 (Fits all Beds /Cabs)

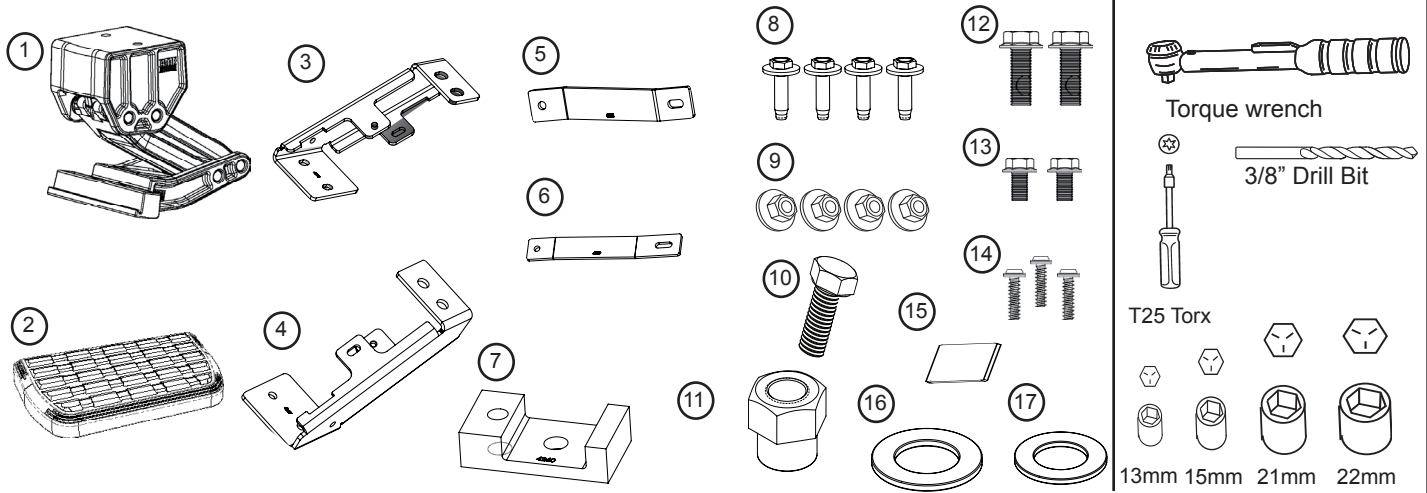

Brackets must be configured for Passenger or Driver-Side as shown below:

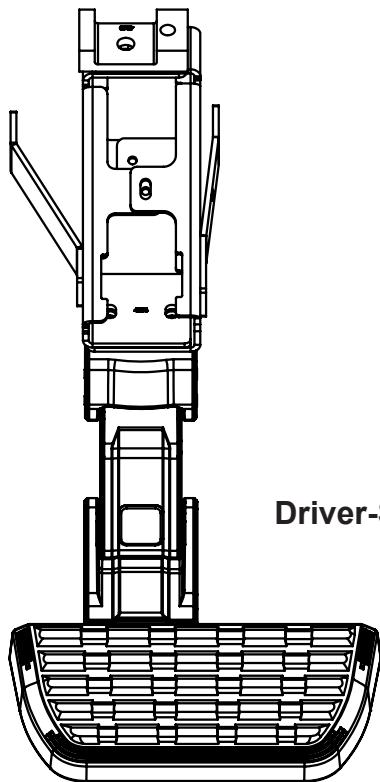

Driver-Side Orientation

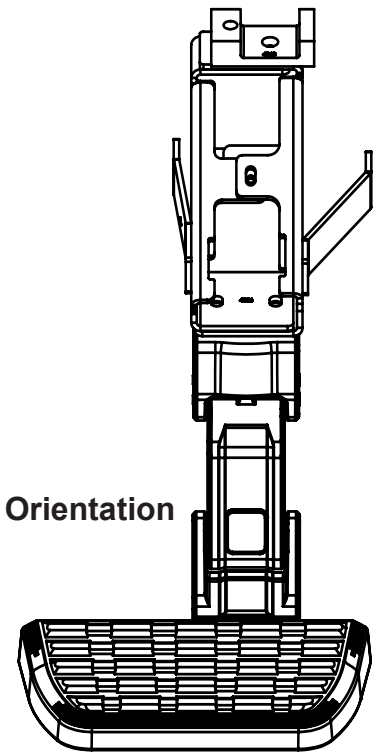

Passanger-Side Orientation

1
AMP RESEARCH TECH SUPPORT 1-888-983-2204 (Press 2) Monday - Friday, 6:00 AM - 5:00 PM PST

BedStep2™ is invented, designed, engineered and manufactured exclusively by AMP Research and may be covered by one of the following patents: 6,641,158; 6,830,257; 6,938,909; 7,055,839; 7,380,807; 7,398,985; 7,584,975. Made in USA © 2011 AMP Research
Three-year limited warranty. Professional installation is recommended.

Assemble brackets as shown in next three steps.

Note: Driver side shown. Rotate frame spacer 180° for passenger side. (See image in step 1 for passenger orientation).

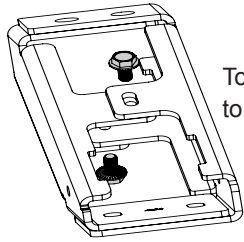

Torque bolts to 20 ft-lbs.

2

Using a 13mm socket assemble the brackets using (#13) bolts.

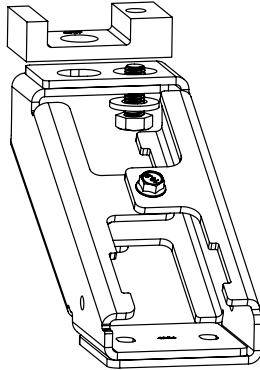

Do not tighten bolts.

Attach Frame spacer to assembled bracket using (#10) bolt and (#17) Washer.

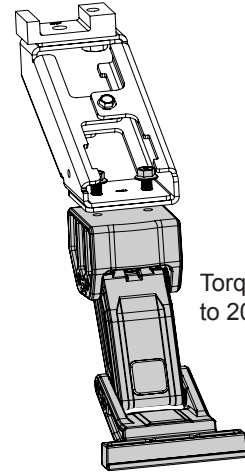

Torque bolts to 20 Ft Lbs.

Using 15 mm socket, attach bracket to linkage using two (#12) bolts.

Using a 21mm Socket assemble Frame mount onto Lateral mount. Do not tighten bolts yet.

3

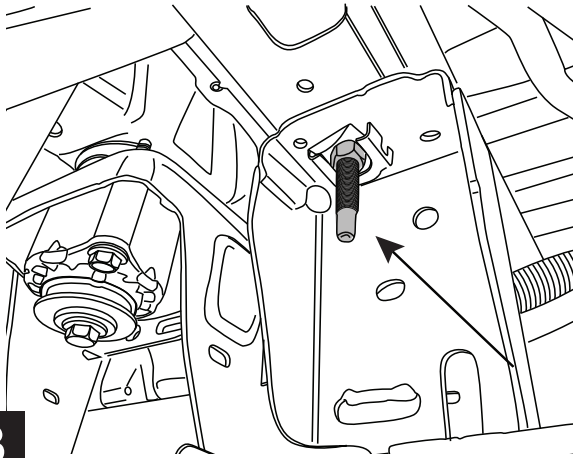

Snug Sleeve nut (#11) to frame, to allow for adjustment. Do not torque.

4

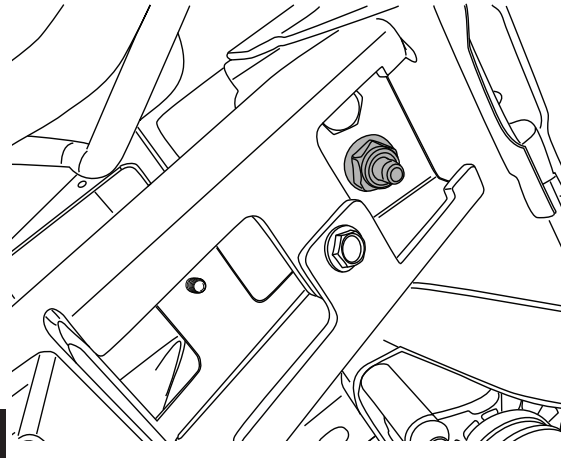

Offset the step pad to the rear position of the lower linkage assembly and secure using provided PT Screws (14). Tighten to 5 ft-lbs using T25 Torx bit.

5

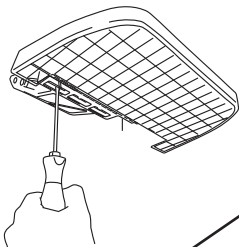

Adjust step pad to be in line with fender .

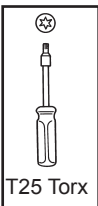
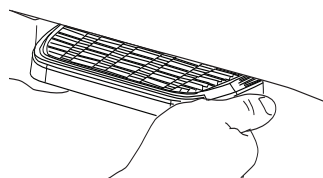

6

Verify that step pad is parallel to the bottom of the body line. A shim (#15) is provided to level out step pad. See image above for explanation.

Install Shim on this edge to increase the gap on the front side of step pad.

Install Shim on this edge to increase the gap on the rear side of step pad.

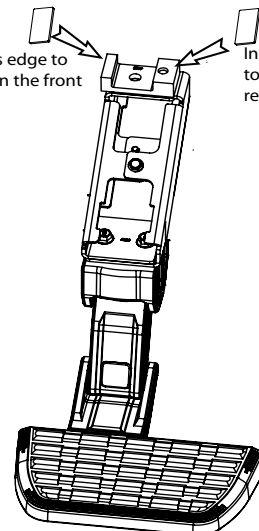

Torque both the Flange nut (#11) and bolt (#10) to 30 Ft Lbs.

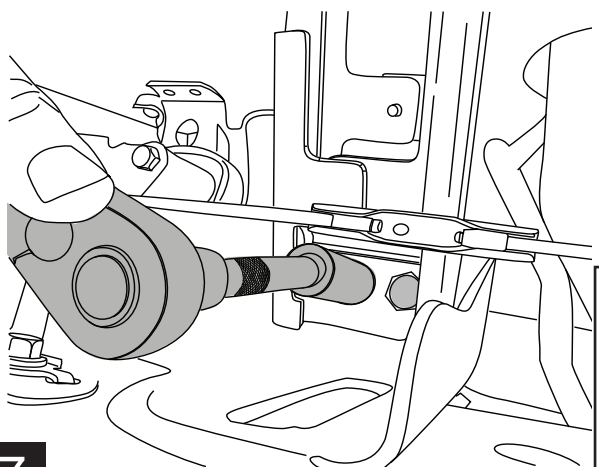

7

Install forward support bracket (#5) using supplied M8 hardware (#8) bolts and (#9) nuts. Torque bolts to 16Ft-Lbs.

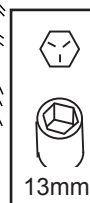
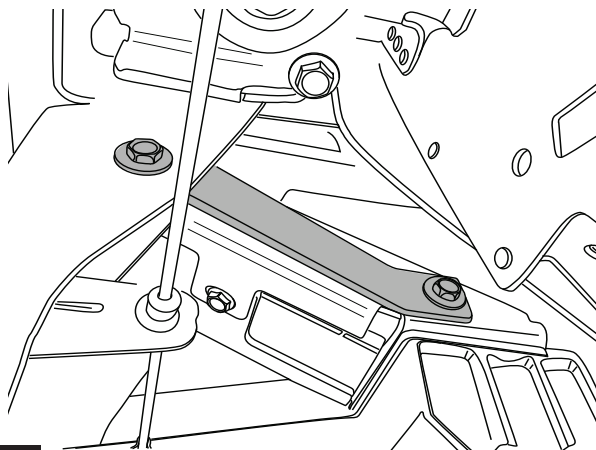

8

Attach rearward support bracket (#6) using supplied M8 hardware (#8) Bolts and (#9) Nuts. Locate bracket as shown. Center punch hole using bracket as a guide as shown.

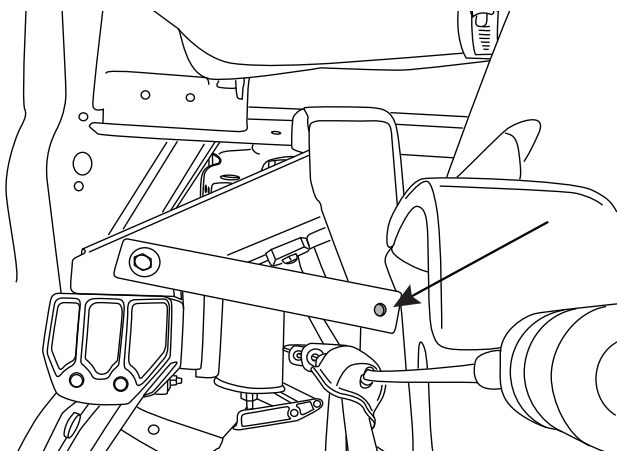

9

Remove bracket and pre drill hole using a 1/8" drill bit then drill to 3/8".

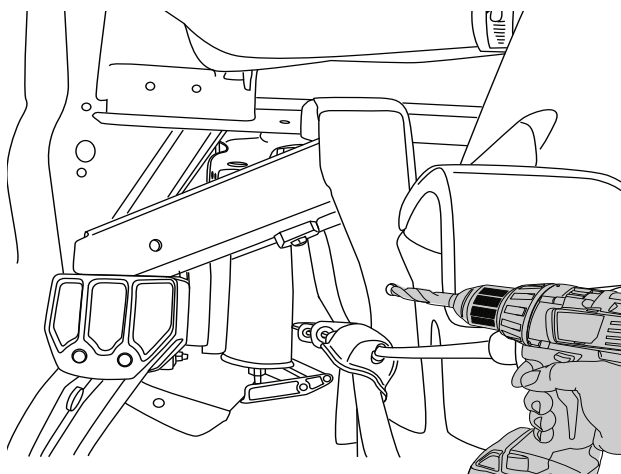

10

Install rearward support bracket (#6) using supplied M8 Hardware (#8) Bolts and (#9) Nuts. Torque to 16Ft-Lbs.

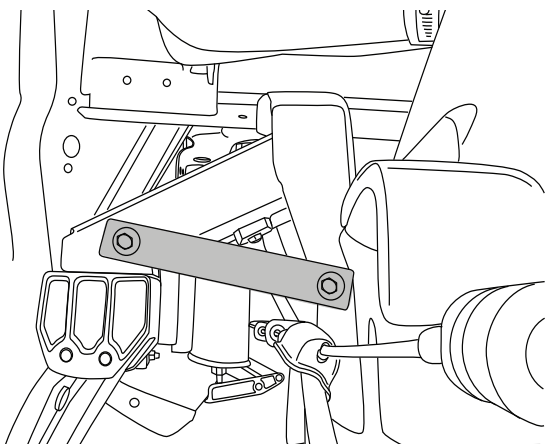

11

To deploy the step, press down using your foot on the outside edge of the step pad.

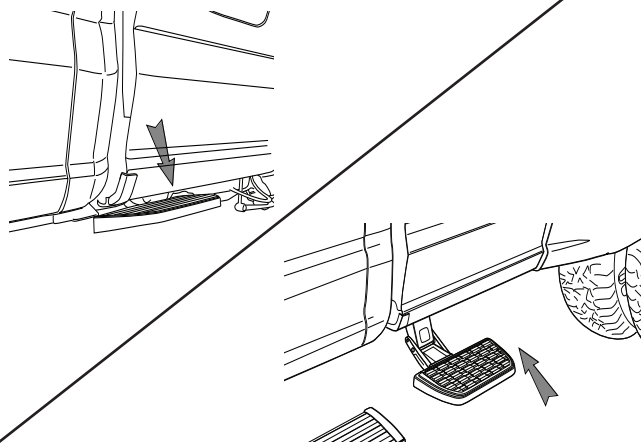

12

To retract, gently kick up on the underside of the step pad.



Congratulations on your purchase of the genuine AMP Research BedStep2™. Here's what you should know...



BEDSTEP2™ OPERATION

The AMP Research BedStep2™ is foot operated and deploys and retracts with a nudge of your foot. To deploy, press down using your foot, on the outside edge of the step pad.

Maximum load capacity of the deployed step pad is 300 lbs.

Always use appropriate hand holds when stepping up to or down from your truck's cargo bed.



To retract, gently kick up on the underside of the step pad.

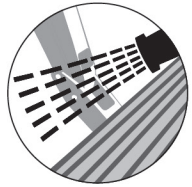

MAINTENANCE TIPS - The stepping surface and linkage should be periodically washed with mild soap and water using a soft brush or sponge to dislodge any mud, dirt or accumulated road grime.

In severe driving conditions, pressure washing the linkage is strongly recommended.

Do not apply silicone spray, waxes or protectants like Armor All® to the stepping surfaces.

CAUTION! BEDSTEP2™ SHOULD ALWAYS BE STOWED IN THE RETRACTED POSITION WHEN DRIVING.

AMP RESEARCH LIMITED WARRANTY

AMP RESEARCH warrants this product to be free from defects in material and workmanship for THREE (3) YEARS FROM DATE OF PURCHASE, provided there has been normal use and proper maintenance. This warranty applies to the original purchaser only. All remedies under this warranty are limited to the repair replacement of the product itself, or the repair or replacement of any component part thereof, found by the factory to be defective within the time period specified. The decision to repair or replace is wholly within the discretion of the manufacturer.

This warranty specifically excludes labor. If you have a warranty claim, first you must call our factory at the number below for instructions. You must retain proof of purchase and submit a copy with any items returned for warranty work. Upon completion of warranty work, if any, we will return the repaired or replaced item or items to you freight prepaid. Damage to our products caused by accidents, fire, vandalism, negligence, misinstallation, misuse, Acts of God, or by defective parts not manufactured by us, is not covered under this warranty.

ANY IMPLIED WARRANTIES OF MERCHANTABILITY AND/OR FITNESS FOR A PARTICULAR PURPOSE CREATED HEREBY ARE LIMITED IN DURATION TO THE SAME DURATION AND SCOPE AS THE EXPRESS WRITTEN WARRANTY. OUR COMPANY SHALL NOT BE LIABLE FOR ANY INCIDENTAL OR CONSEQUENTIAL DAMAGE.

Some states do not allow limitations on how long an implied warranty lasts, or the exclusion or limitation of incidental or consequential damages, so the above limitations or exclusions may not apply to you. This warranty gives you specific legal rights, and you may also have other rights that vary from state to state.

FOR WARRANTY ISSUES WITH THIS PRODUCT PLEASE CALL AMP RESEARCH CUSTOMER SERVICE 1-888-983-2204

WARNING

Be sure to read and precisely follow the provided instructions when installing this product. Failure to do so could place the vehicle occupants in a potentially dangerous situation. After installing or reinstalling, re-check to insure that the product is properly installed.