

# INSTALLATION GUIDE

# AMP RESEARCH Power Step

MADE IN USA

## APPLICATION

AMP Part #

Chevrolet Silverado1500 / GMC Sierra 1500 - Crew Cab 2007-2013 77126-01A

Chevrolet Silverado 2500/3500 - Crew Cab 2007-2014 77126-01A

GMC Sierra 2500/3500

**(Excludes all 2011-up models with Diesel Engine.)**

**Note: The application works only on the Crew Cab model Vehicles.**

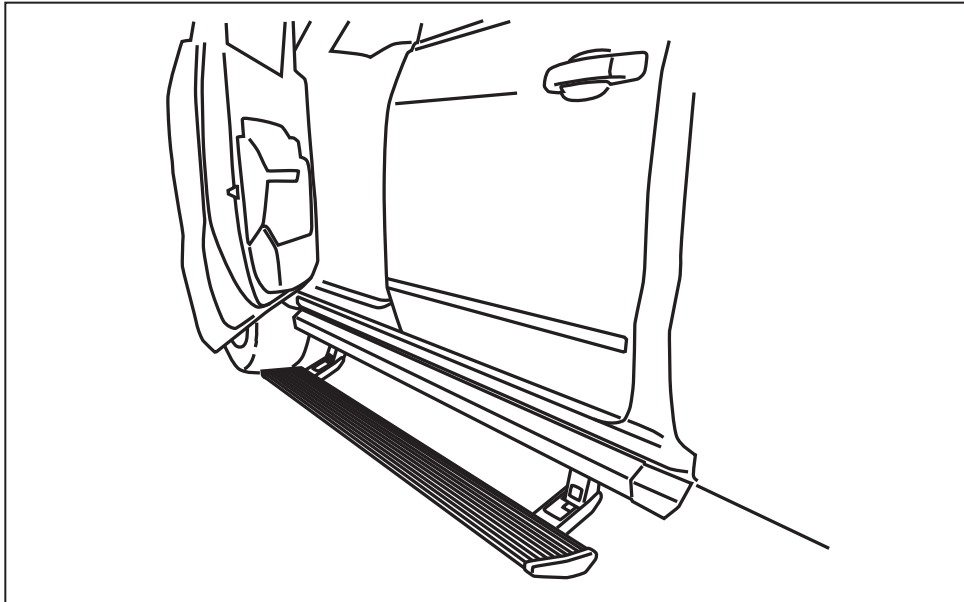

## INSTALLATION TIME

**3-5 Hours**

Professional installation recommended

## SKILL LEVEL



4= Experienced

## TOOLS REQUIRED

- Safety goggles
- Measuring tape
- Power Drill
- 10 mm socket
- 13 mm socket
- 1/2" socket
- Ratchet wrench and extension
- Wire crimpers
- Wire stripper / cutter
- 3/16" hex key wrench ( allen wrench )
- 4mm hex key wrench ( allen wrench )
- Electrical tape
- Weather proof caulking (silicone sealer)
- Silicone spray

## WARRANTY

**5-Year Limited Warranty**

AMP RESEARCH TECH SUPPORT 1-888-983-2204 (Press 2) Monday - Friday, 6:00 AM - 5:00 PM PST

Invented, engineered and manufactured exclusively by AMP Research in the USA. May be covered by one of the following patents: 6,641,158; 6,830,257; 6,834,875; 6,938,909; 7,055,839; 7,380,807; 7,398,985; 7,584,975 ©2012 AMP Research. All rights reserved. Printed in USA.

## INSTALLATION GUIDE

Attaching motor to Linkage assembly.

## EXPLODED VIEW

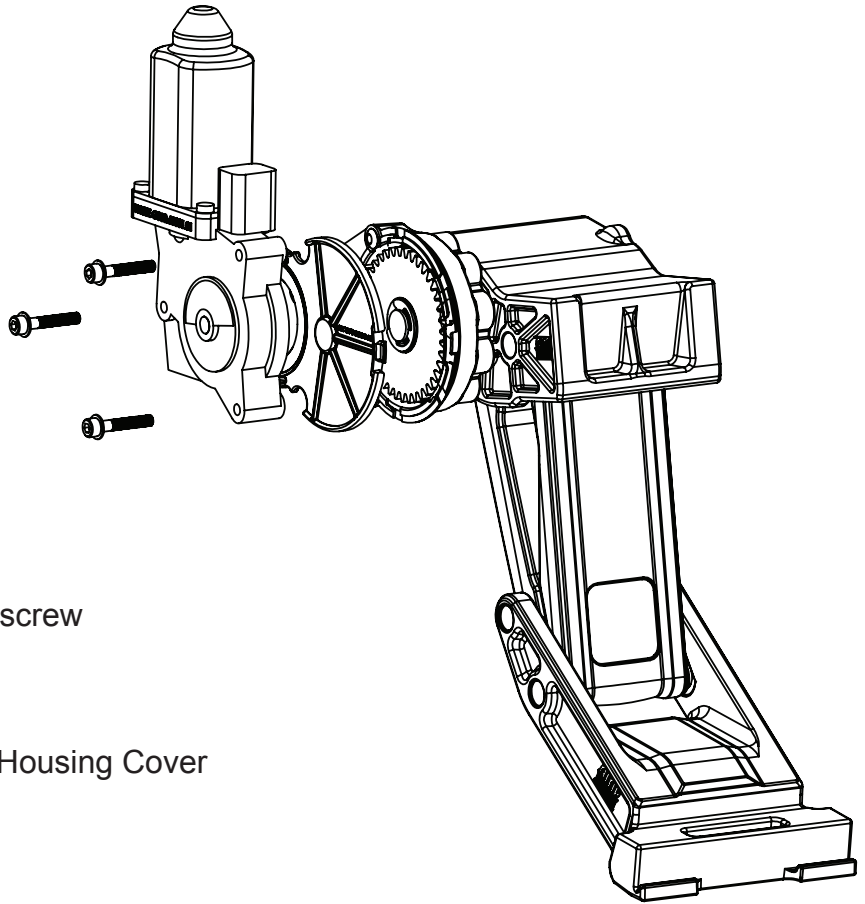

80-03129-90	Motor
19-03179-90	Socket cap screw
19-03133-90	Washer
19-03138-90	Drive Gear Housing Cover

**CAUTION: HANDLE WITH CARE.**

To ensure our customers receive all components with full integrity, we pack the motors separate from their linkage assemblies. This requires that the installer position and fasten the motor before continuing with the install. Please follow the instructions below and handle the assembly carefully.

**CAUTION:** Dropping the assembly or any excessive impact MAY cause damage to the motor.

## Instructions:

1. Position the gear cover in place as shown if not already in place.
2. Seat motor into position on the three mounting bosses. This may require an adjustment of the gear by moving the swing arms.
3. After seating into place, fasten the motor with the three motor mount screws with 4mm Hex Head. Tighten screws to 36 in-lbs (4N-m). **Do not over torque.**

AMP RESEARCH POWERSTEP™ – CHEVROLET / GMC

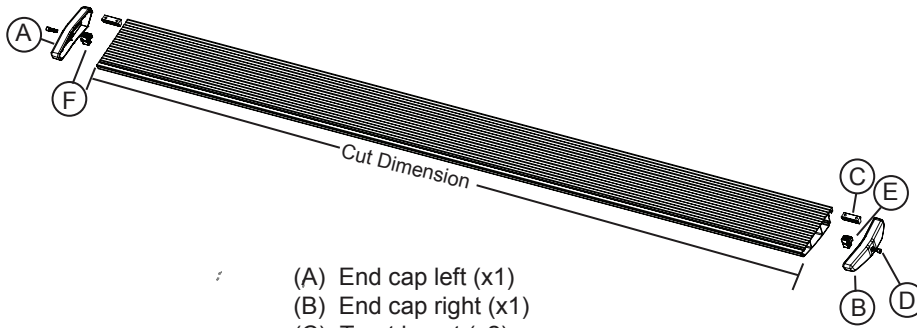

- (A) End cap left (x1)
- (B) End cap right (x1)
- (C) T-nut insert (x2)
- (D) Socket cap screw (x2)
- (E) End cap wedge right (x1)
- (F) End cap wedge left (x1)

1 x2

Running board assembly

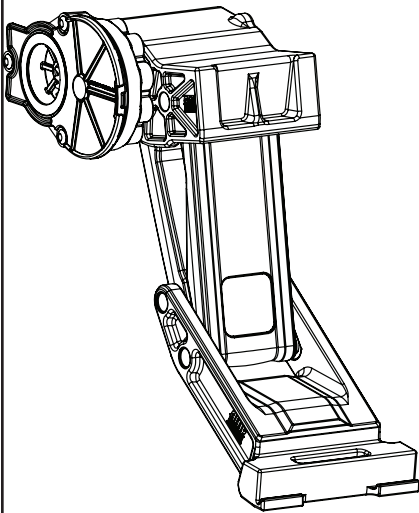

2 x2

Motor Linkage assembly

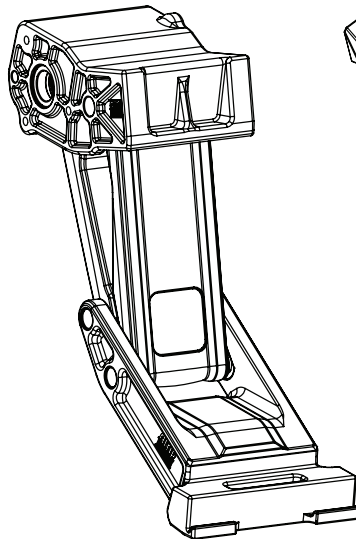

3 x2

Idler Linkage assembly

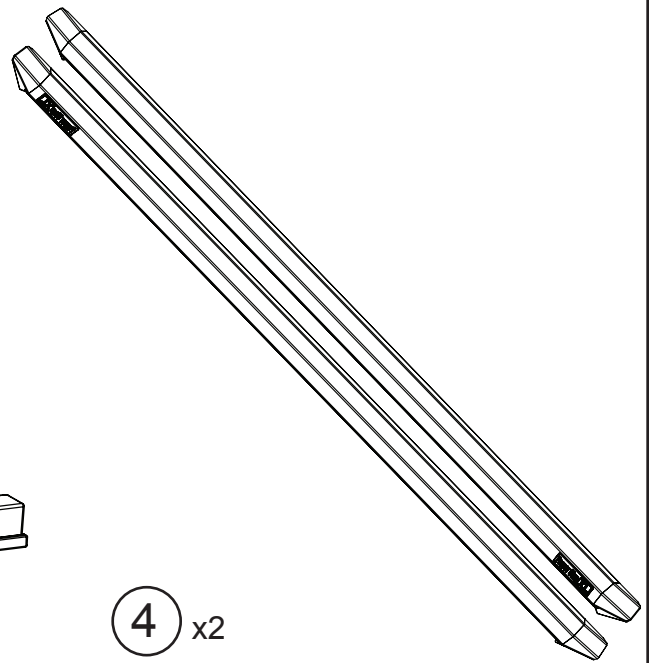

4 x2

Rail Assembly

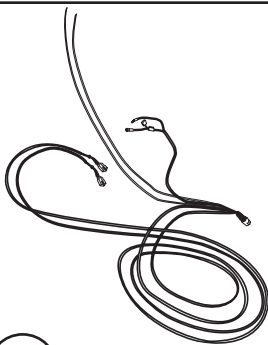

5

Wire harness

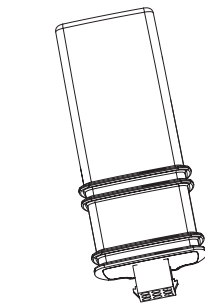

6

A06 Controller



7 x4

Posi-Tap™

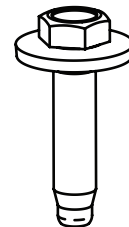

8 x20

M8 Hex Bolt w  
Conical washer

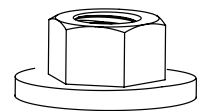

9 x6

M8 Nut w Conical  
washer

AMP RESEARCH POWERSTEP™ – CHEVROLET / GMC

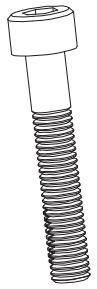

**10** x6  
M5 Hex Bolt



**11** x6  
M5 Washer

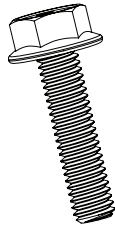

**12** x4  
M6 Flange Bolt

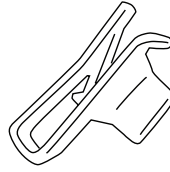

**13** x6  
M8 U-nut

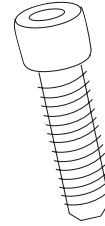

**14** x8  
Socket Cap Screw

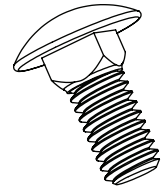

**15** x10  
5/16-18  
Carriage Bolt

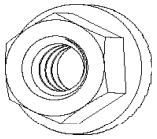

**16** x10  
5/16-18  
Flange nut

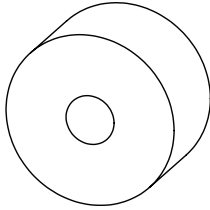

**17** x4  
Upper Mount  
Spacer

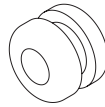

**18**  
19-02640-90  
Grommet

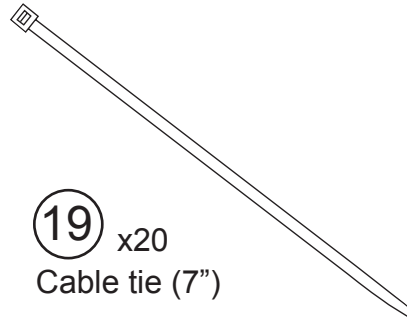

**19** x20  
Cable tie (7")

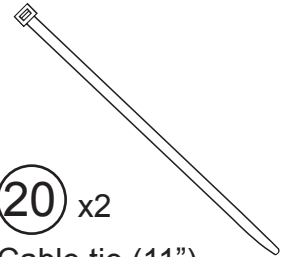

**20** x2  
Cable tie (11")

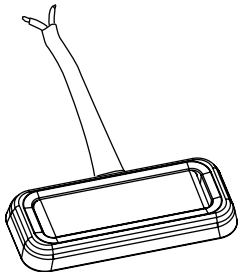

**21** x4  
LED Lamp

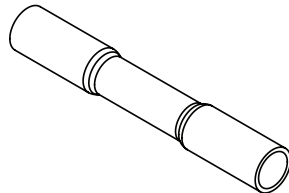

**22** x8  
Butt Connector

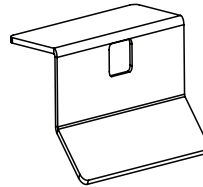

**23** x4  
LED Light Bracket

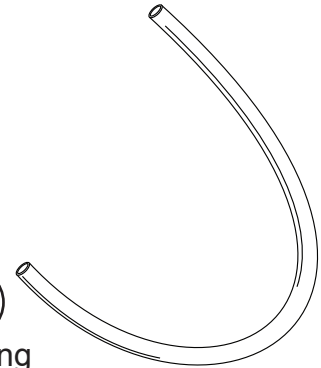

**24**  
Tubing  
(installation tool)

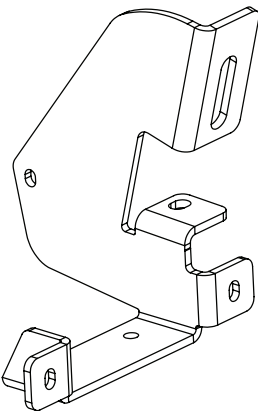

**25** x4  
Linkage Mounting  
Bracket

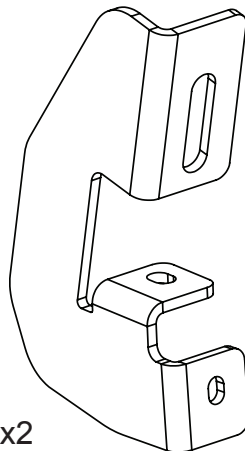

**26** x2  
Rail Mounting  
Bracket

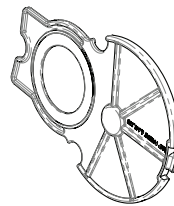

**27** x2  
Gear Cover

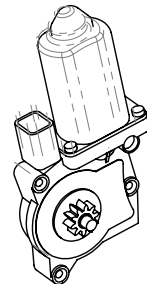

**28** x2  
Motor

**AMP RESEARCH POWERSTEP™ – CHEVROLET / GMC**

Insert and position Carriage bolts (15) into slot on rail (4). Insert from either end of rail. Using Flange Nuts (12) provided assemble Brackets 2x (25) & 1x (26) onto the rail (4). Driver side shown. Dimensions shown are for reference. **Do not tighten this will allow for rail adjustment when mounted onto vehicle.**

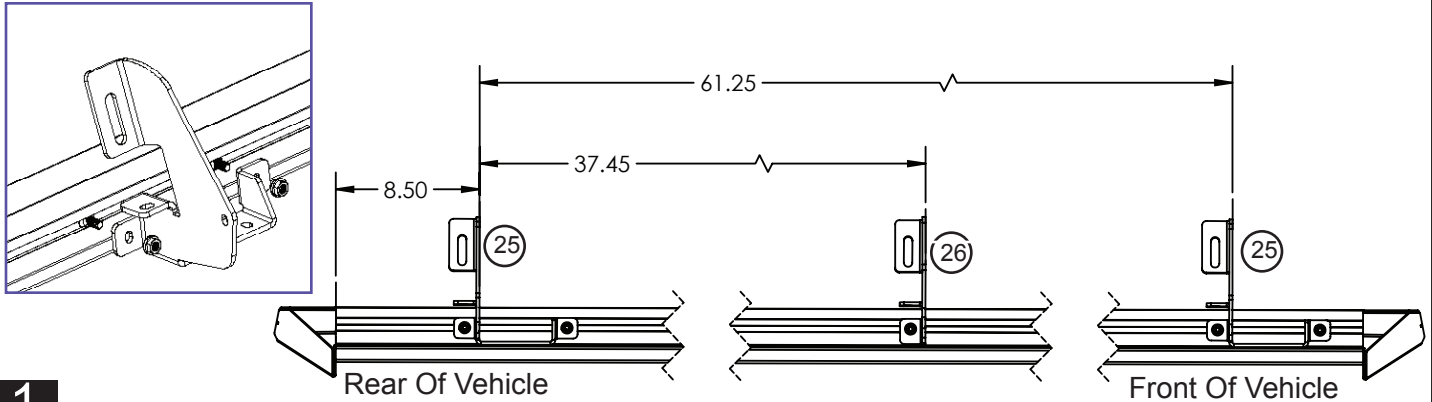

**1**

**Note: Badge on rail sits towards the rear of the vehicle!**

Insert U-Nut in last sheetmetal tab / hole from front.

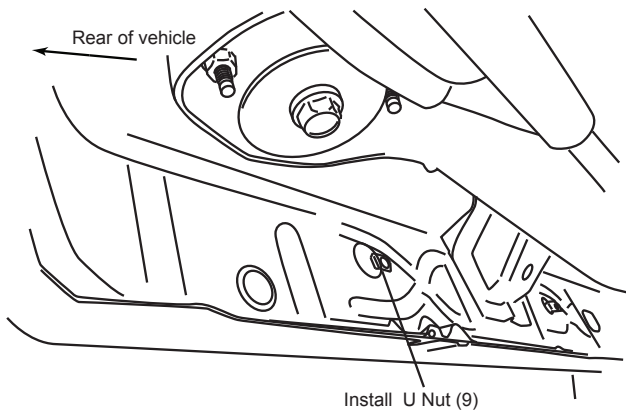

**2**

Set rail up into position. Starting with the rear bracket work towards the two front brackets. Attach Bolts 2x (8) and Nut 1x (9). Snug to body do not tighten!  
**Note: Forward and middle bracket may not need nut if threaded insert is present.**

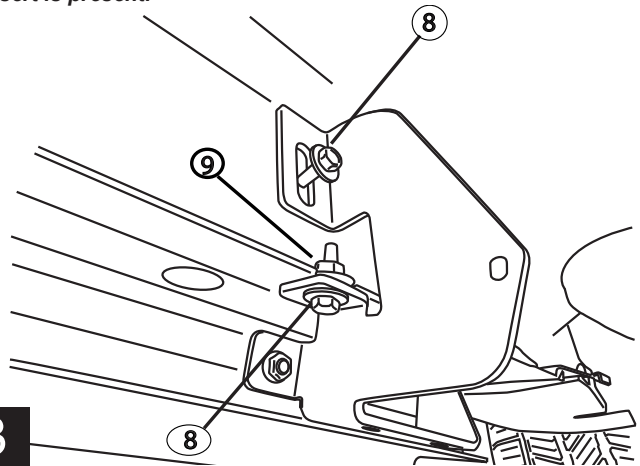

**3**

Thread supplied bolts 2x (8) into Rear Drive Linkage. Repeat step for Front Idler Linkage. Do not tighten.

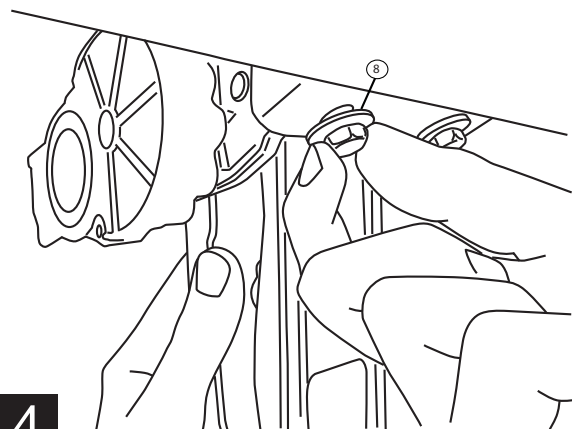

**4**

Install provided spacer (17) and M6 bolt (12) into upper mount as shown on both the Drive and Idler linkages. Do not tighten.

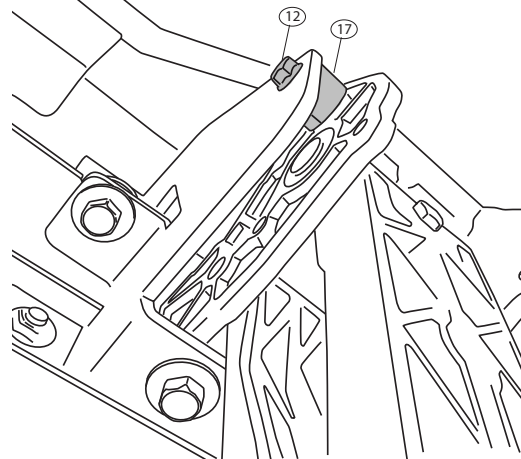

**5**

**AMP RESEARCH POWERSTEP™ – CHEVROLET / GMC**

Slide mounting T-nut into position, Center board in rail pocket. Tighten fasteners to 10 ft-lbs.

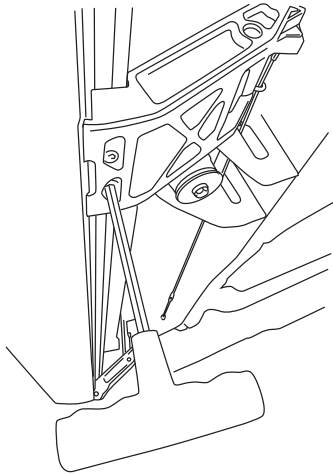

**6**

Using a 13mm socket Torque linkage bolts 4x (8) from step 5 to 16 ft-lbs Next use a 10mm socket, torque linkage spacer bolt 2x (12) from step 6 to 8 ft-lbs.

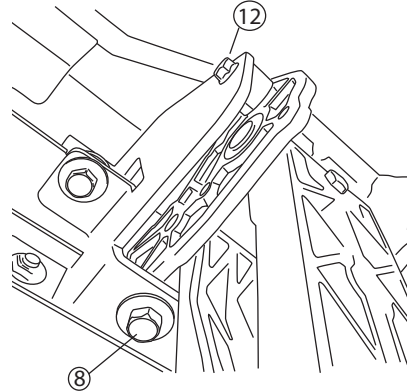

**7**

Verify rail clearance at front fender trim and push upwards on rail to ensure rail is snug to the bottom of the linkage mounting bracket. Using a 1/2" socket start at the rear of vehicle and work forward. Torque 5 flange nuts (16) to 16ft-lbs.

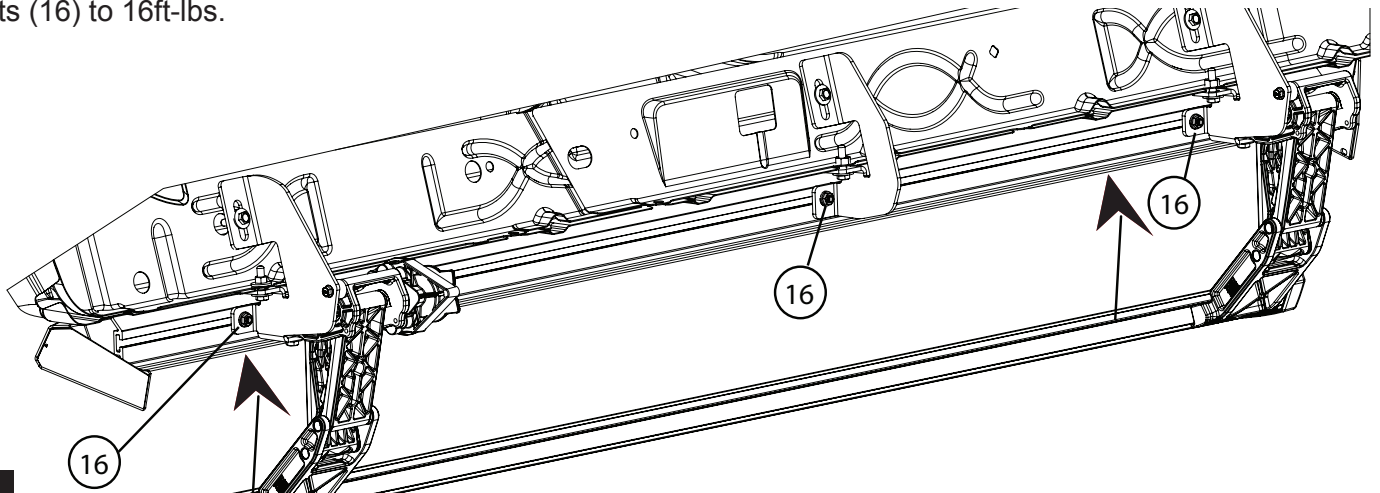

**8**

**A:** Using a 13mm socket tighten 3 bolts along pinch weld first. Torque to 16ft-lbs.  
**B:** Next torque 3 upper sill bolts to 16ft-lbs.

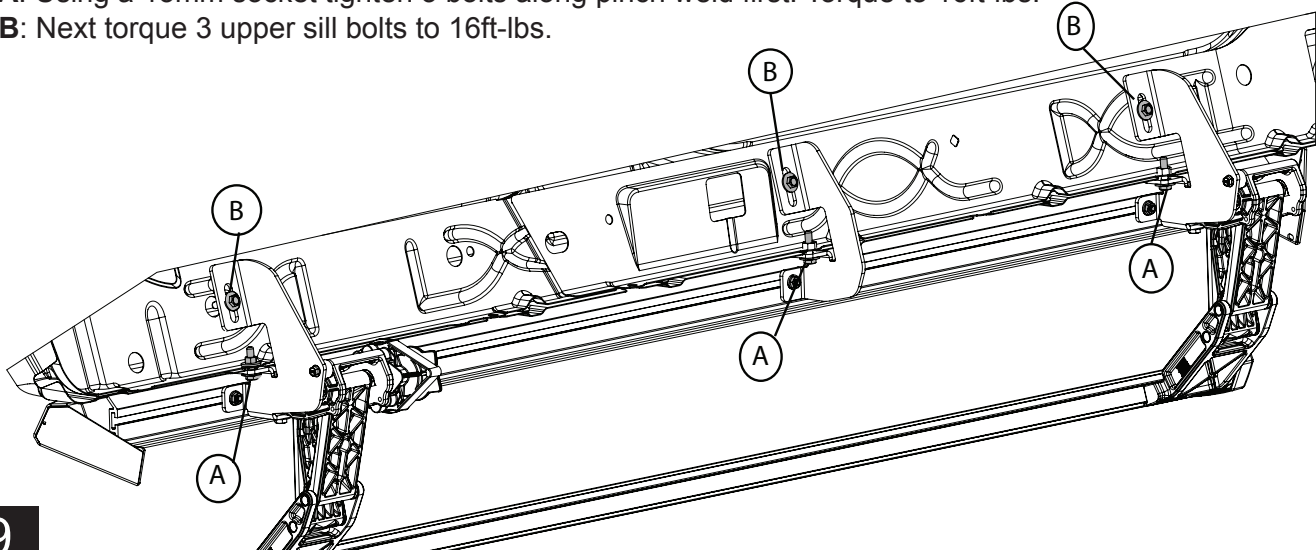

**9**



Using the two 11" cable ties, mount controller to support arm next to battery. (Behind support arm on diesel engine) **On Hybrid models: Mount controller on drivers side of engine compartment.**

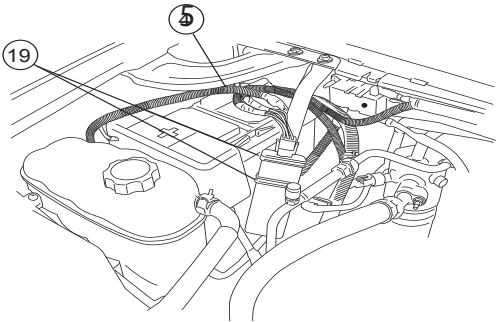

Remove power fuse. Attach power lead (RED wire) to positive pole on the battery.

**CAUTION:** Do not ground wrench when engaged with nut.

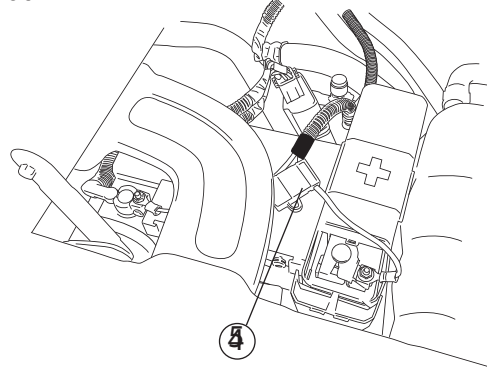

**10** Plug in wire harness. (Ensure that locking tabs engage.)

**11** Attach ground lead to negative battery pole.

**GAS ENGINE WIRE ROUTING**

Route long end of wire harness above engine and down through drivers side wheel well. Zip tie harness to cowlings clips on fire wall. Route short end down passengers side. **On Hybrid models: Long end of wires will be routed down through passenger side wheel well and short end down drivers side.**

**DIESEL ENGINE WIRE ROUTING**

Route long end of wire harness under intake and along factory engine harness to driver side wheel well. Route short end down passengers side.

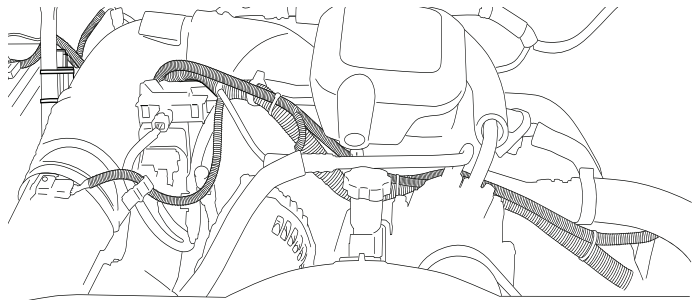
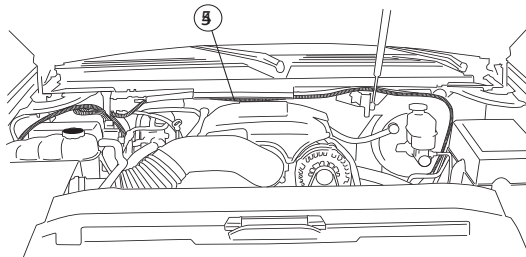

**12** Secure with zip ties.

**13** Secure with zip ties.

Route wire harness along the frame and back towards rear linkage. Secure with zip ties. Poke hole through rubber grommet near front door on underside of floor panel with small phillips screwdriver. Push both wires through hole. (See Step 14 for passenger side notes.)

Pop off the threshold cover with screwdriver and remove the kick panel. **Repeat step on passenger side.**

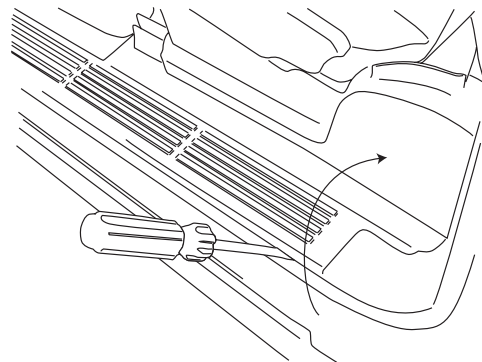
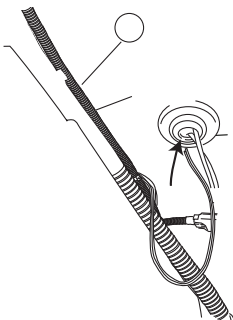

**14**

**15**

Pull up the carpet and thread both wires through the floor panel (same steps on passenger side EXCEPT drill 9/32" hole in metal and add rubber grommet).

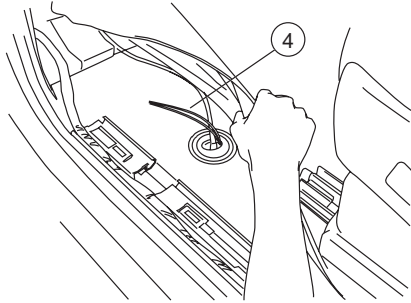

Seal holes with silicone glue and cover with tape so carpet does not stick to glue.

16

**REAR DOORS** - Carefully remove wire wrap and find LIGHT BLUE wire with BLACK STRIPE. On passenger side find GREEN wire with BLACK STRIPE. The wire is located rear of the "T" junction where wires cross under the front seat.

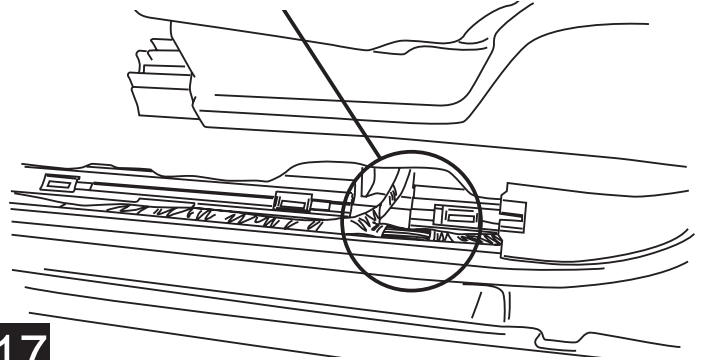

17

**REAR DOORS** - Using supplied Posi-Tap™ connector, splice shorter trigger wire into wire found in Step 16. Otherwise tape off short wire.

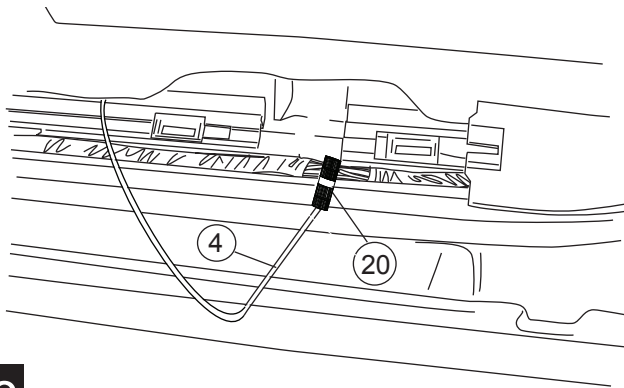

18

For model years 2007-2010 locate and inspect the Body Control Module above the brake pedal under the dashboard. The BCM is the only module with a pink connector. Check to see if the front door ajar signal wires are present in the pink connector: Grey/Black, Tan/White. If you do not see these wires the front door panels must be removed.

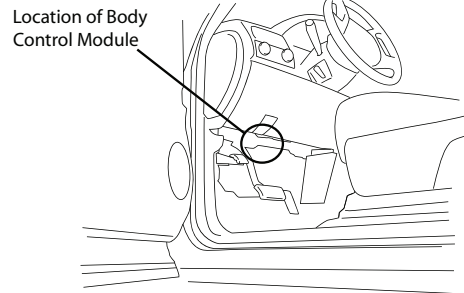

19

Vehicles that do not have the front door ajar signal wires in the pink connector of the BCM must have the front door panels removed in order to access the front door ajar signal wires. **For these and all Hybrid models Go to step 22.**

20

Remove driver side kick panel and open the loom wrapped in grey or black tape to access the Grey / Black stripe wire. In the passenger side kick panel the loom wrapped in green or black tape will have a Tan / White stripe wire. Connect Power Step Grey / Black and Tan / White wires to like colored factory wires.

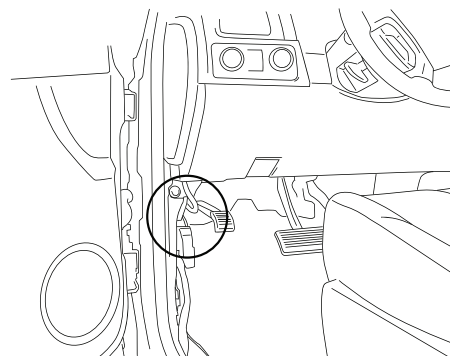

21



Remove plastic trim on door near mirror attachment. Then carefully pry up window/ door lock switch plate.

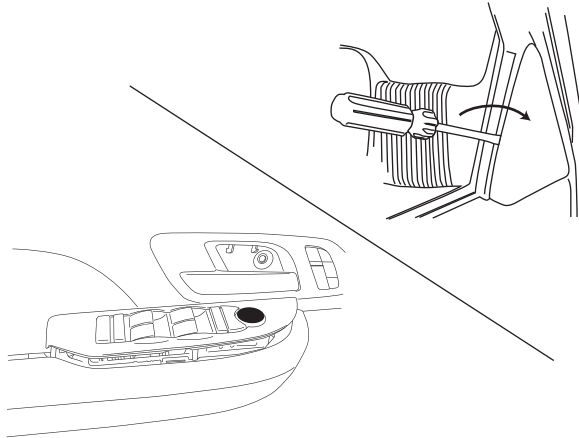

22

Remove all plugs from switchplate

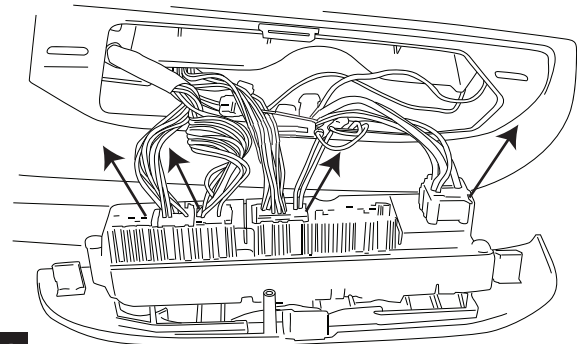

23

To remove door panel, first pry back tab on door lock to remove then pry off plastic covers by handle and door latch. Remove the 3 door bolts and then remove door panel by prying loose all panel fasteners.

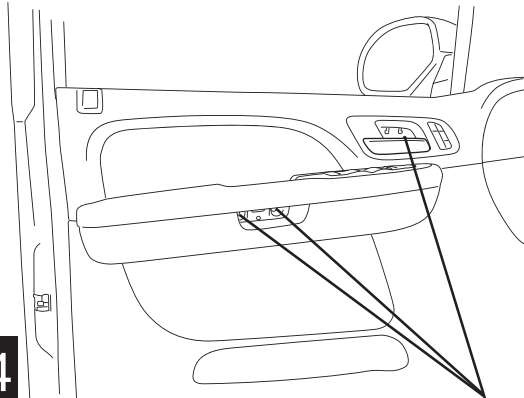

24

Remove door latch cable from door panel.

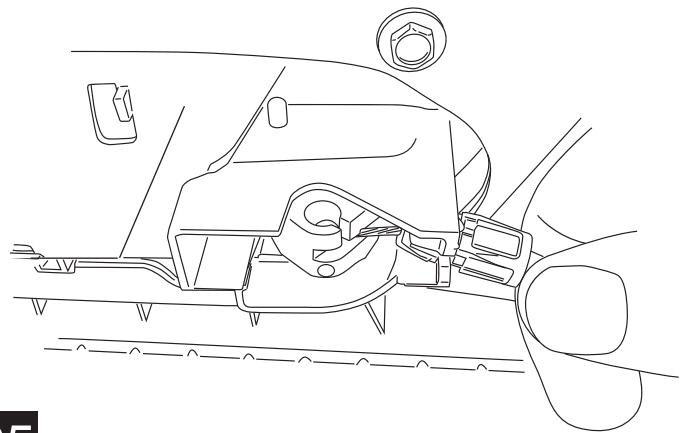

25

Pull back the door weather guard, unbolt speaker and unplug. Thread plastic tube through accordion.



26

Feed longer wire of Step 13 through tube into door and pull out plastic tube on door side. Route wire along harness to switchplate.

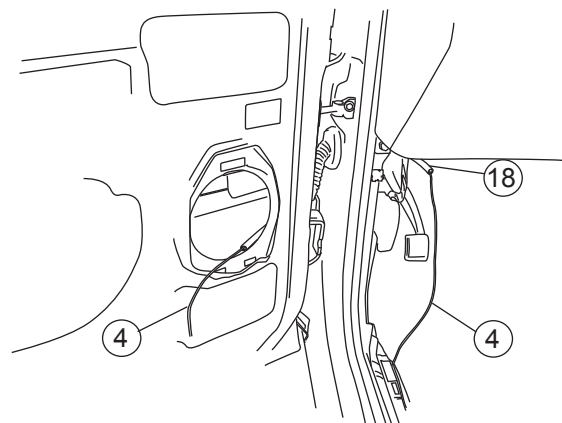

27

**For 2007-2009 Models:**

Locate the brown plug in doors and using supplied Posi-Tap™ connector, splice into trigger wire.  
 Drivers side: Grey / Black wire  
 Passengers side: Tan / White wire  
**Note: On Hybrid models trigger wire colors will not match up because wire harness is flipped.**

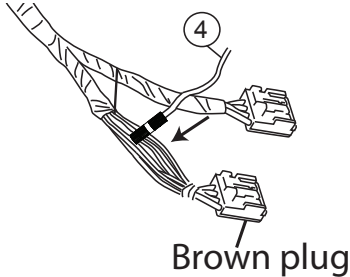

Brown plug

**For 2010-Current models:**

Locate loom that runs across the top of the door panel. Carefully remove wire wrap and locate the following wires on either side. **Drivers side:** Grey / Black wire **Passenger side:** Tan / White wire **Caution:** Zip tie trigger wires to avoid being hung up in window linkage.

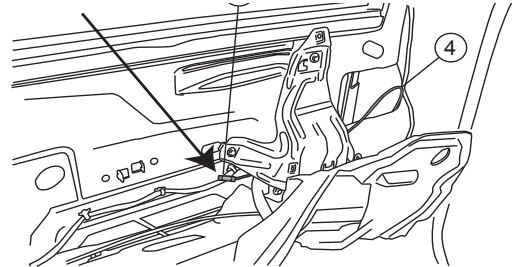

**28** Reassemble door and replace plugs. Plugs must be replaced for Power Step to operate.

**29** **Note: On Hybrid models trigger wire colors will not match up because wire harness is flipped.**

Affix LED lamp (21) to LED Bracket (23) as shown..

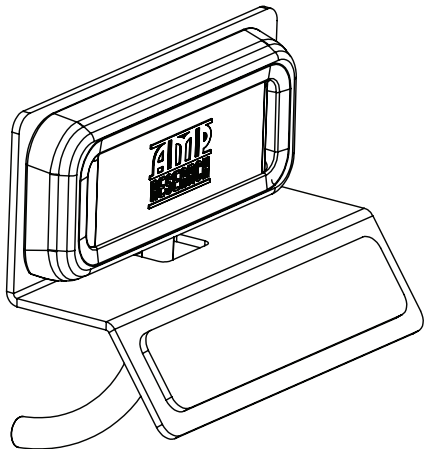

**30**

Affix LED light bracket assembly to rail. Mount front light rearward of front linkage and mount rear light just forward of rear linkage.

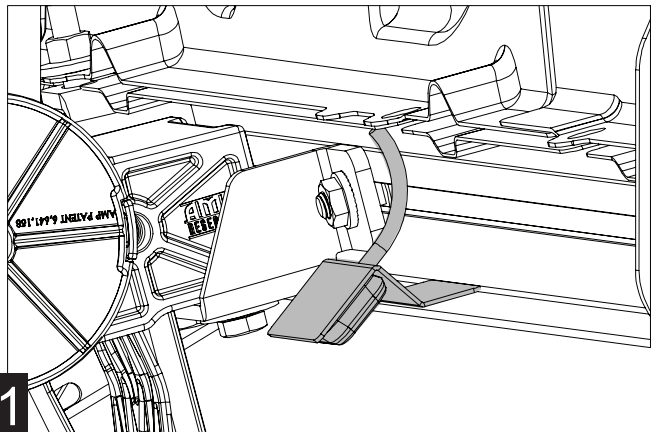

**31**

Using supplied butt connectors, connect the lamp wires. Red to Red, Black to Black. Once Crimped use heat gun to shrink tube. Close and wrap conduit with electrical tape. Secure all loose wires with cable ties. Pull lamp wires upward to avoid any wire snagging.

Attach motor to harness using a 4mm Hex Torque to 36 in-lbs. Connect harness to motor. Secure harness with tie wraps.

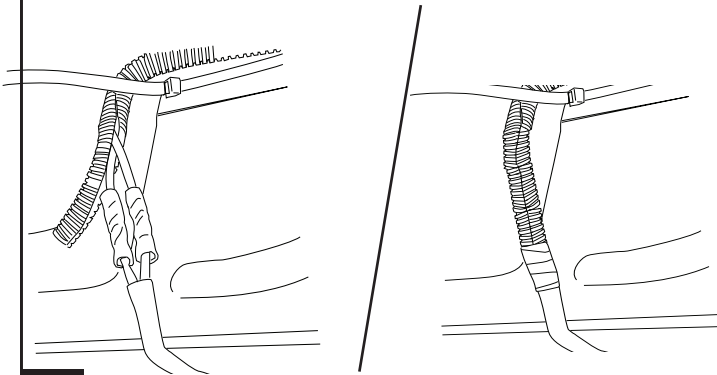

**32**

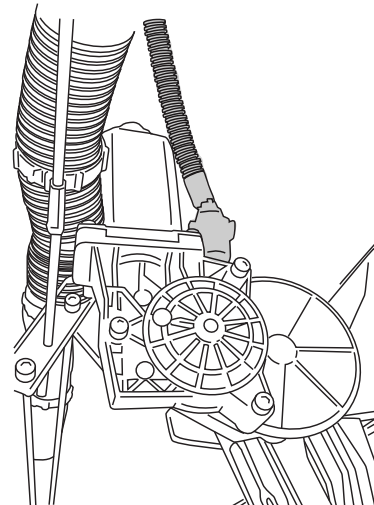

**33**

Check that all doors activate the Power Step and the LED Lights work when doors open and close. Reinstall any remaining trim panels.

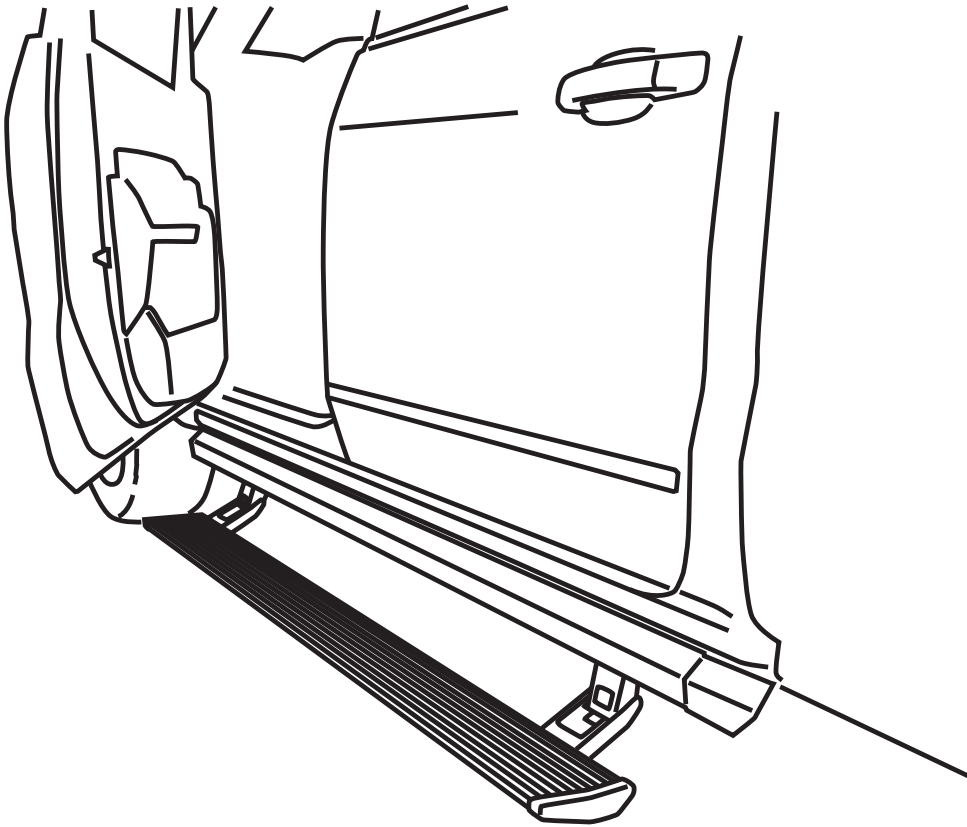

#### FINAL SYSTEM CHECK

Check that all doors activate the PowerStep and the LED lights work when doors open and close.

**NORMAL OPERATION:** When the doors open, PowerStep automatically deploys from under the vehicle. When the doors are closed, PowerStep will automatically return to the stowed/retracted position. ***Note that there is a 2-second delay before the PowerStep returns to the stowed/retracted position.***

**CORRECT OPERATION OF LIGHTS:** All four lamps will illuminate upon opening any door of vehicle. Lamps will stay on until restowing of both Power Steps or until 5 minutes has expired with the doors open. When the lights timeout after 5 minutes, they can be reilluminated by closing and opening any door of vehicle.



# PowerStep™

**Congratulations on your purchase of the genuine AMP Research PowerStep! Here's what you should know...**

**POWER-DEPLOYABLE RUNNING BOARDS OPERATION:** AMP Research PowerStep running boards automatically move when the doors are opened to assist entering and exiting the vehicle.



**Automatic power deploy:**

The running boards will extend down and out when the doors are opened.

**Automatic power stow:**

The running boards will return to the stowed position when the doors are closed. There will be a 2-second delay before the running boards move to the stowed position.

**Automatic stop:**

If an object is in the way of the moving running board, the running board will automatically stop. To reset, clear any obstruction, then simply open and close the door to resume normal operation.



**Manually set in the deployed (OUT) position for access to the roof:**

The running boards can be manually set in the deployed position by firmly holding the step down with your foot while at the same time closing the door. To resume normal operation, open and close the door.

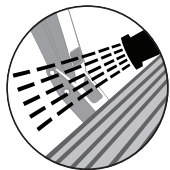

**Maintenance:** In adverse conditions, debris such as mud, dirt, and salt may become trapped in the running board mechanism, possibly leading to unwanted noise. If this occurs, manually set the running boards to the deployed position and flush the front and rear hinge arms with a high-pressure car wash wand.

Avoid spraying the motors directly. After washing, apply silicone spray lubricant to the hinge pivot pins. Do not apply silicone, wax or protectants like Armor All® to the running board stepping surface.

**Caution!** Keep hands away when the running board is in motion.

## 5-YEAR LIMITED WARRANTY

AMP RESEARCH warrants this product to be free from defects in material and workmanship for FIVE (5) YEARS FROM DATE OF PURCHASE, provided there has been normal use and proper maintenance. This warranty applies to the original purchaser only. All remedies under this warranty are limited to the repair replacement of the product itself, or the repair or replacement of any component part thereof, found by the factory to be defective within the time period specified. The decision to repair or replace is wholly within the discretion of the manufacturer.

This warranty specifically excludes labor. If you have a warranty claim, first you must call our factory at the number below for instructions. You must retain proof of purchase and submit a copy with any items returned for warranty work. Upon completion of warranty work, if any, we will return the repaired or replaced item or items to you freight prepaid. Damage to our products caused by accidents, fire, vandalism, negligence, misinstallation, misuse, Acts of God, or by defective parts not manufactured by us, is not covered under this warranty.

ANY IMPLIED WARRANTIES OF MERCHANTABILITY AND/OR FITNESS FOR A PARTICULAR PURPOSE CREATED HEREBY ARE LIMITED IN DURATION TO THE SAME DURATION AND SCOPE AS THE EXPRESS WRITTEN WARRANTY. OUR COMPANY SHALL NOT BE LIABLE FOR ANY INCIDENTAL OR CONSEQUENTIAL DAMAGE.

Some states do not allow limitations on how long an implied warranty lasts, or the exclusion or limitation of incidental or consequential damages, so the above limitations or exclusions may not apply to you. This warranty gives you specific legal rights, and you may also have other rights that vary from state to state.

**FOR WARRANTY ISSUES WITH THIS PRODUCT PLEASE CALL AMP RESEARCH CUSTOMER SERVICE 1-888-983-2204**

## WARNING

Be sure to read and precisely follow the provided instructions when installing this product. Failure to do so could place the vehicle occupants in a potentially dangerous situation. After installing or reinstalling, re-check to insure that the product is properly installed.