



INSTALLATION INSTRUCTIONS

- Tools recommended but not limited to: 9/16" wrench & socket, marker, floor jack, jack stands.
- Park vehicle on flat, solid ground. Engage parking brake. Place wheel chocks. Jack up rear axle and secure with jack stands.
- Pre-assemble Aeon Spring (#1) + optional 1/2" spacer (#2) (determine if required - see clearance requirement on next page) + disc (#3) to bracket (#6) using hardware (#4, #7, #8).

Place assembly on top of axle. Slide forward/backward until it sits in proper mounting location. Look straight up at frame rail and mark bracket (#6) directly underneath. This mark is exact center for Aeon Spring (Fig. 1).

- Slide assembly within bracket slot until spring center aligns with mark, then tighten securely (Fig. 2).
- Place complete assembly onto axle. Clamp from below using hardware (#7, #8, #9). **Note:** Keep brake lines and wire harness clear. Do NOT pinch or stretch any OE parts.

(Ranger Raptor → Fig. 3; Bronco Full-Size → Fig. 4)

- Remove jack stands. Lower vehicle to ground. Verify proper clearance and performance.

INSTRUCTIONS DE MONTAGE

- Outils recommandés mais non limités à : clé et douille de 9/16", marqueur, cric de sol, chandelles.

- Garez véhicule sur surface plane et solide. Engagez frein de stationnement. Placez cales de roue. Levez essieu arrière et soutenez avec chandelles.

- Pré-assemblez ressort Aeon (#1) + entretoise optionnelle 1/2" (#2) (déterminez si nécessaire - voir exigence de dégagement page suivante) + disque (#3) sur support (#6) à l'aide de matériel (#4, #7, #8). Placez assemblage sur dessus d'essieu. Glissez avant/arrière jusqu'à position de montage correcte. Regardez verticalement vers longeron de châssis et marquez support (#6) directement dessous. Cette marque est centre exact pour ressort Aeon (Fig. 1).

- Glissez assemblage dans fente du support jusqu'à ce que centre du ressort s'aligne avec marque, puis serrez solidement (Fig. 2).

- Placez assemblage complet sur essieu. Fixez par dessous avec matériel (#7, #8, #9). **Note :** Gardez conduites de frein et faisceau électrique dégagés. Ne pincez ni n'étirez aucune pièce OE. (Ranger Raptor → Fig. 3; Bronco Full-Size → Fig. 4)

- Retirez chandelles. Abaissez véhicule au sol. Vérifiez dégagement correct et performance.

INSTRUCCIONES DE INSTALACION

- Herramientas recomendadas pero no limitadas a: llave y dado de 9/16", marcador, gato de piso, soportes.

- Estaciona el vehículo en superficie plana y sólida. Activa el freno de mano. Coloca calzos de rueda. Eleva el eje trasero y asegúralo con soportes.

- Pre-ensambla resorte Aeon (#1) + espaciador opcional de 1/2" (#2) (determina si es necesario - ver requisito de espacio en la siguiente página) + disco (#3) en el soporte (#6) usando hardware (#4, #7, #8). Coloca el ensamblaje sobre el eje. Desliza hacia adelante/atrás hasta que quede en la posición de montaje correcta. Mira directamente hacia arriba al riel del chasis y marca el soporte (#6) justo debajo. Esta marca es el centro exacto para el resorte Aeon (Fig. 1).

- Desliza el ensamblaje dentro de la ranura del soporte hasta que el centro del resorte se alinee con la marca, luego aprieta firmemente (Fig. 2).

- Coloca el ensamblaje completo sobre el eje. Fija desde abajo usando hardware (#7, #8, #9). **Nota:** Mantén las líneas de freno y el arnés de cables libres. NO pellizques ni estires ninguna pieza OE. (Ranger Raptor → Fig. 3; Bronco Full-Size → Fig. 4)

- Retira los soportes. Baja el vehículo al suelo. Verifica el espacio adecuado y el rendimiento.

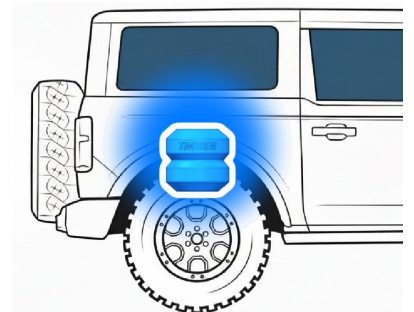
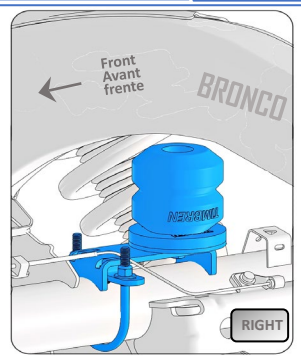
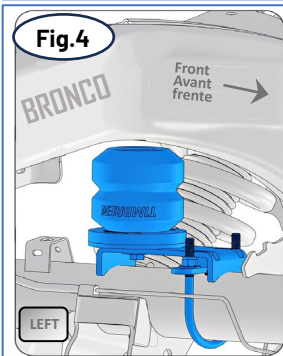
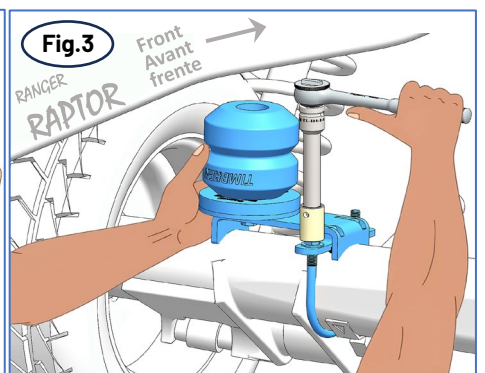
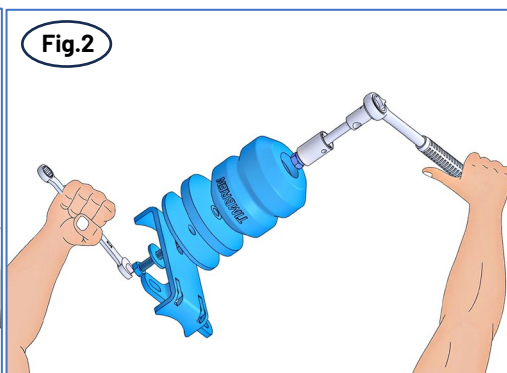
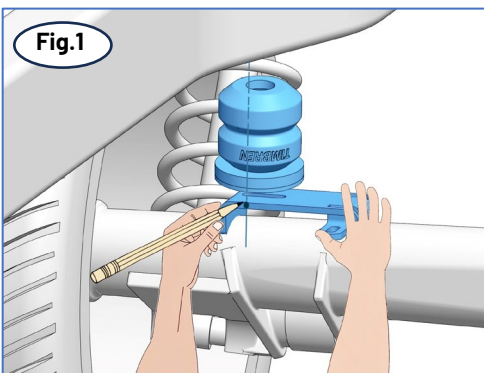



ASSEMBLY
ASSEMBLÉE
ASSEMBLAGE

PARTS
PIÈCE
PIEZA

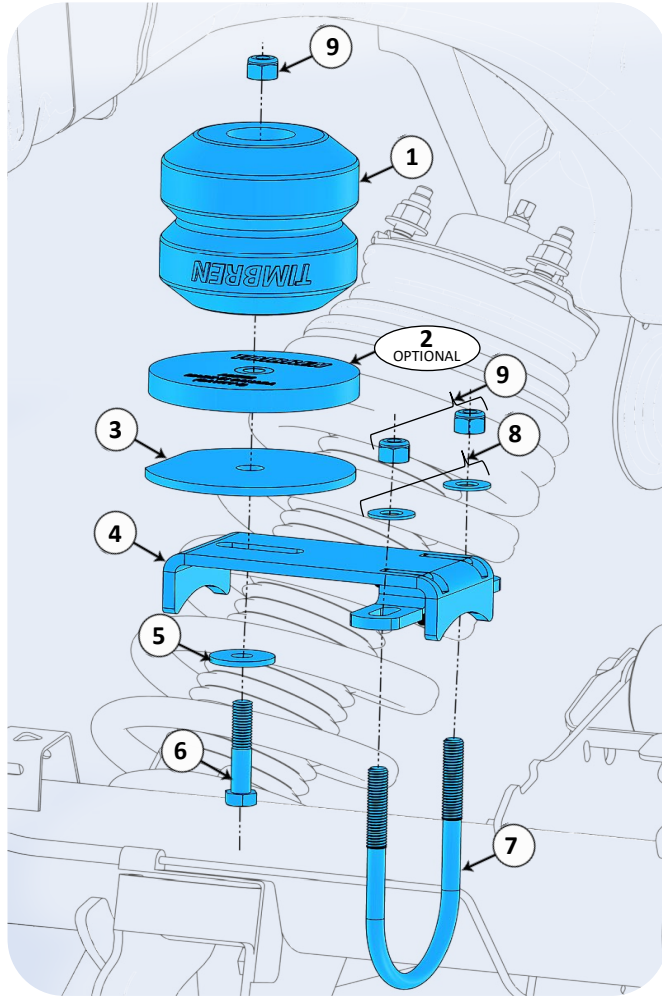

REFERENCE RÉFÉRENCE REFERENCIA	PART NO. NUMÉRO DE PIÈCE NÚMERO DE PIEZA	QUANTITY QUANTITÉ CANTIDAD
1	A00550-65P30	2
2	A25722-90P00	2
3	K54005-003	2
4	K11050-003	2
5	F42032-020	2
6	F11065-250	2
7	F17U05-250	2
8	F40040-086	4
9	F31003-250	6

OVERALL, KIT HEIGHT: 5.5"

WARNINGS

Do not exceed vehicle manufacturers recommended axle weight rating. Check for AEON® interference with vehicle components. Under load AEON® will expand in diameter.

Ne pas dépasser le poids nominal sur l'essieu recommandé par le fabricant du véhicule. Vérifier que le ressort AEON® ne pas d' incidence sur d' autres pièces du véhicule. Le ressort AEON® augmentera son diamètre avec la charge.

No exceda la carga nominal en el eje recomendada por el fabricante del vehículo. Compruebe que no haya interferencia entre el resorte AEON® y los otros componentes del vehículo. Bajo carga el resorte AEON® se amplía en diámetro.

CAUTION

Never work under a vehicle supported only by a jack—always use jack stands. Wear safety glasses and gloves to protect yourself from debris and sharp edges.

CLEARANCE INSTRUCTIONS

Rear SES Kits for Pick-Ups and Vans should have a 1/2" to 1-1/2" gap between the rubber spring and contact point when empty. A partial load, or vehicle accessories will reduce or eliminate the gap. Front SES kits are usually in full contact. Medium and Heavy-Duty Trucks, Trailers and Motorhomes will be in constant contact, and have no gap.

LIFETIME WARRANTY

TIMBREN INDUSTRIES INC. www.timbren.com ASSEMBLY NOTES: PARTS SUPPLIED LOOSE

Timbren SES Kits are warranted against defects in material and workmanship, under normal use and service, for the life of the vehicle on which the kit was originally installed. The warranty is not transferable and proof of purchase is required. The warranty is limited to the replacement of the failed part. TIMBREN will not be responsible for any labour or freight charges involved in the replacement of any product. TIMBREN shall be entitled to make its own inspection to determine the validity of the claim. TIMBREN shall not be liable nor warranty the product in the event of alteration, misuse, overload, negligence or damage caused by others. If ride or performance of our product is unsatisfactory in any way, please call: 1-800-263-3113 or email sales@timbren.com