

LoadLifter 5000™ SERIES + Air Lift® ProSeries



Installation Guide



Ford F350 Dual Rear Wheel



Watch the video
Info on Table of Contents page

Kits 57380 | 88380 | 93380

For maximum effectiveness and safety, please read these instructions completely before proceeding with installation.

Failure to read these instructions can result in an incorrect installation.

Protect your Air Lift Purchase by Completing your Warranty Registration

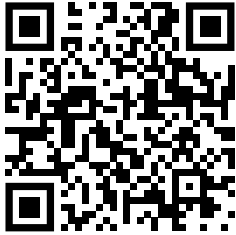

Thank you for purchasing an Air Lift load support product!

Take a photo of your sales receipt and then scan the QR code to complete your online warranty registration.

TABLE OF CONTENTS

2 System Overview

3 Hardware and Tools

4 Introduction

Notation Explanation
Identifying the Differences Between Kits

5 Installing the System

Prepare the Vehicle
Assembling the Air Springs
Installing the Air Spring Assemblies

12 Installing the Air Lines

Installing the Heat Shield

14 Finished Installation

15 Before Operating

Installation Checklist
Maintenance and Use Guidelines

16 Limited Warranty and Return Policy

Video-enhanced installation guides

Visit airliftcompany.com/workshop/category/install-videos to access our installation video archive*.

Hardware and Tools

Common Parts Included in All 3 Kits

Item	Part#	Description	Qty
A	01531	Clamp bar	2
B	03014	Lower bracket, main plate	2
C	03223	Lower bracket, cup	2
D	07045	Upper bracket, frame	2
E	07220	Upper bracket, air spring	2
H	11770	U-bolt	2
I	17361	3/8"-16 x 1 1/4" Carriage bolt	8
J	17366	M10-1.5 x 35 Button-head cap screw	4
K	17387	3/8"-16 x 10" Carriage bolt	4
L	17500	5/16"-18 x 3/4" Carriage bolt	2
M	18404	5/16"-18 Serrated flange lock nut	2
P	18622	M10-1.5 Universal nut	4
Q	18422	3/8"-16 Serrated flange lock nut	8
R	21837	Push-to-connect (PTC) fitting	2
V	18444	3/8" Flat washer	8
W	18435	3/8"-16 Nylon lock nut	8
AA*	20086	Air line assembly	1
BB*	10466	Zip ties	6
CC*	21230	Valve cap	2
DD*	18411	Star washer	2
EE*	21234	Rubber washer	2
FF*	18501	M8 Flat washer	2
GG*	21233	5/16" Hex nut	4
HH*	09484	Thermal Sleeve	1
II*	10613	Heat Shield	1
JJ*	10741	4 1/2" Clamp	2
KK*	10555	3 1/2" Clamp	2

* These parts are not shown in the System Overview (Fig.1).

TOOLS NEEDED

Description	Qty
Standard and metric open-end or box wrenches	SET
Ratchet	1
Standard and metric sockets	SET
5/16" drill bit (very sharp)	1
9/16" Crow's foot adapter	1
9/16" ratchet combo wrench	1
Heavy-duty drill	1
Torque wrench	1
Standard and metric hex-key wrenches	1
Flat-tip screwdriver	1
Hose cutter, razor blade, or sharp knife	1
Hoist or floor jacks	1
Safety stands	2
Safety glasses	1
Air compressor or compressed air source	1
Spray bottle with dish soap/water solution	1

The photos in this manual show the LoadLifter 5000 kit.

Unique Parts in Each Kit

LoadLifter 5000™ KIT 57380

Item	Part#	Description	Qty
F	11951	Roll plate (silver zinc-plated)	4
G	58437	Air spring	2
N	18444	3/8" Flat washer	4
S	17215	3/8"-24 x 3/4" Flat-head socket-cap screw	4
T	17203	3/8"-24 x 7/8" Hex-cap screw	4
U	18427	3/8" Lock washer	4

LoadLifter 5000™ ULTIMATE KIT 88380

Item	Part#	Description	Qty
F	11967	Roll plate (black powder coat)	4
G	58496	Air spring w/ jounce bumper	2
N	18444	3/8" Flat washer	4
S	17215	3/8"-24 x 3/4" Flat-head socket-cap screw	4
T	17203	3/8"-24 x 7/8" Hex-cap screw	4
U	18427	3/8" Lock washer	4

Air Lift® ProSeries KIT 93380

Item	Part#	Description	Qty
F	11951	Roll plate (silver zinc-plated)	4
G	58937	Air spring	2
N	18507	3/8" Stainless steel flat washer	4
S	17363	3/8"-24 x 3/4" Stainless FHSC screw	4
T	17284	3/8"-24 x 7/8" Stainless steel hex-cap screw	4
U	18504	3/8" Stainless steel lock washer	4
II*	21838	Tee fitting	1



Missing or damaged parts? Call Air Lift customer service at (800) 248-0892 for a replacement part.

Introduction

The purpose of this publication is to assist with the installation and maintenance of the LoadLifter 5000 series and Air Lift ProSeries air spring kits. All LoadLifter 5000 series and Air Lift ProSeries kits utilize sturdy, reinforced, commercial-grade single or double, depending on the kit, convolute bellows.

The air springs are manufactured like a tire with layers of rubber and cords that control growth. LoadLifter 5000 series and Air Lift ProSeries kits provide up to 5,000 pounds (2,268kg) of load-leveling support with air adjustability from 5-100 PSI (.34-7BAR).

It is important to read and understand the entire installation guide before beginning installation or performing any maintenance, service or repair.

NOTATION EXPLANATION

Hazard notations appear in various locations in this publication. Information highlighted by one of these notations must be observed to help minimize risk of personal injury or possible improper installation, which may render the vehicle unsafe. Notes are used to help emphasize areas of procedural importance and provide helpful suggestions. The following definitions explain the use of these notations as they appear throughout this installation guide.



INDICATES IMMEDIATE HAZARDS WHICH WILL RESULT IN SEVERE PERSONAL INJURY OR DEATH.



INDICATES HAZARDS OR UNSAFE PRACTICES WHICH COULD RESULT IN SEVERE PERSONAL INJURY OR DEATH.



INDICATES HAZARDS OR UNSAFE PRACTICES WHICH COULD RESULT IN DAMAGE TO THE MACHINE OR MINOR PERSONAL INJURY.



Used to help emphasize areas of procedural importance and provide helpful suggestions.

IDENTIFYING THE DIFFERENCES BETWEEN KITS

Should you need to contact Air Lift customer service, you will need to know which kit you are inquiring about: standard LoadLifter 5000, LoadLifter 5000 Ultimate or standard Air Lift ProSeries. The kits are easily identifiable by looking at the end caps on the air spring and the roll plates.

- Standard **LoadLifter 5000™** — Plastic end cap and Zinc-plated steel roll plates.
- LoadLifter 5000™ Ultimate** — Plastic end cap and Black powder-coated roll plates.
- Standard **Air Lift® ProSeries** — Aluminum end cap and Zinc-plated steel roll plates.



LoadLifter 5000
Plastic end cap



LoadLifter 5000
silver zinc-plated steel roll plate



LoadLifter 5000 Ultimate
Plastic end cap



LoadLifter 5000 Ultimate
black powder-coated roll plate



Air Lift ProSeries
Aluminum end cap



Air Lift ProSeries
silver zinc-plated steel roll plate

Installing the System

PREPARE THE VEHICLE

1. Raise the vehicle and support it, using safety stands or equivalent, so that the axle can be safely lowered away from the frame. This needs to be done in order for the air spring assembly to be put into position between the axle and frame (Fig. 2).

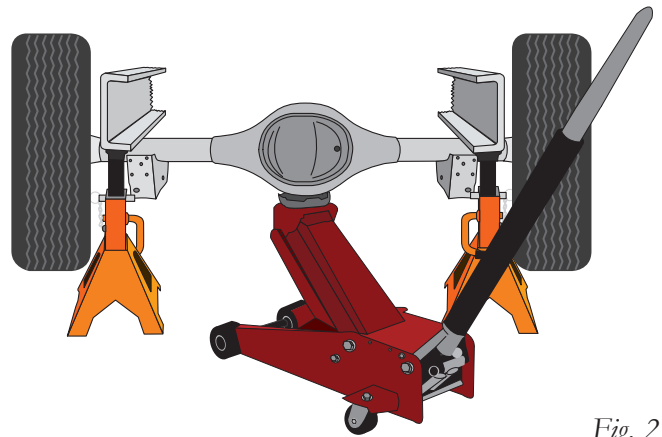

Fig. 2

2. Unbolt and remove the jounce bumper assembly from under the frame on both sides (Fig. 3).



Fig. 3

3. Remove the clip-in studs by prying on the hinged end with a screwdriver. Pull all four (two from each side) out from the frame (Fig. 4).

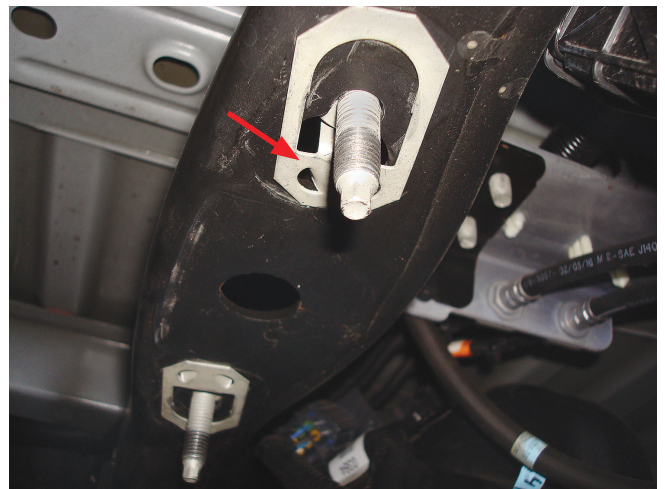

Fig. 4

4. Install the universal nuts (P) into the frame rail, lining up the holes in the frame and the threads in the nuts so that a bolt can be installed (Fig. 5).



A flat-tip screwdriver works well in installing the universal nut into position.

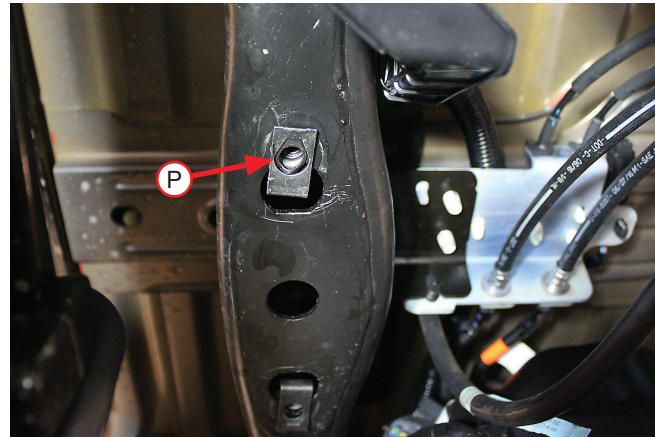

Fig. 5

5. Insert the 3/8"-16 x 1 1/4" carriage bolts (I) into the upper frame brackets (D). Install the upper bracket onto the frame using the M10-1.5 x 35mm button-head cap screws (J). The slot on the side of the bracket should be inboard of the frame rail (Fig. 6). The elongated hole should be toward the front of the truck (Fig. 7). Torque hardware to 38 lb.-ft. (52Nm).

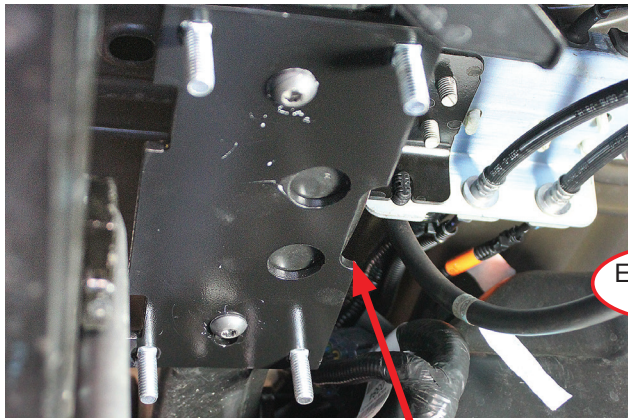

Fig. 6

This slot in the bracket goes inboard, away from leaf spring and tire

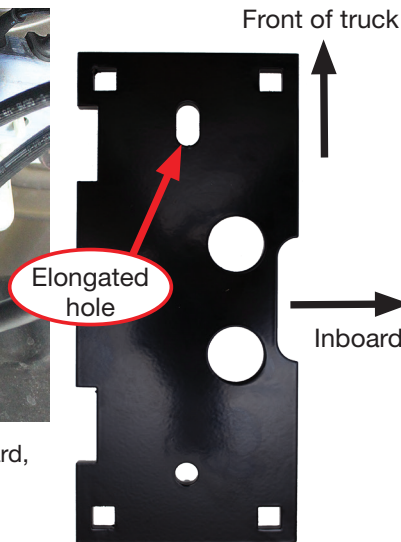

Fig. 7

ASSEMBLING THE AIR SPRINGS

1. Set a roll plate (F) on top of the air spring (G). The radiused, or rounded, edge of the roll plate should be toward the air spring so that it is seated inside the roll plate (Fig. 8). Install the 90-degree swivel fitting (R) into the port on top of the air spring finger-tight plus 1 1/2 turns.

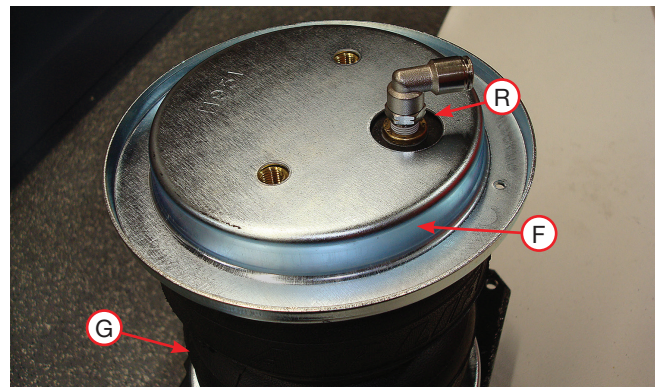

Fig. 8

- Set the upper air spring bracket (E) onto the top of the air spring using one set of holes with the 3/8"-24 x 7/8" hex-cap screw (T), 3/8" lock washer (U) and 3/8" flat washer (N) (Fig. 9). Install the remaining air spring bracket onto the remaining air spring, using the opposite holes from those that were previously used. This makes the air spring assemblies into left- and right-hand units. Torque the hardware to no more than 20 lb.-ft. (27Nm).

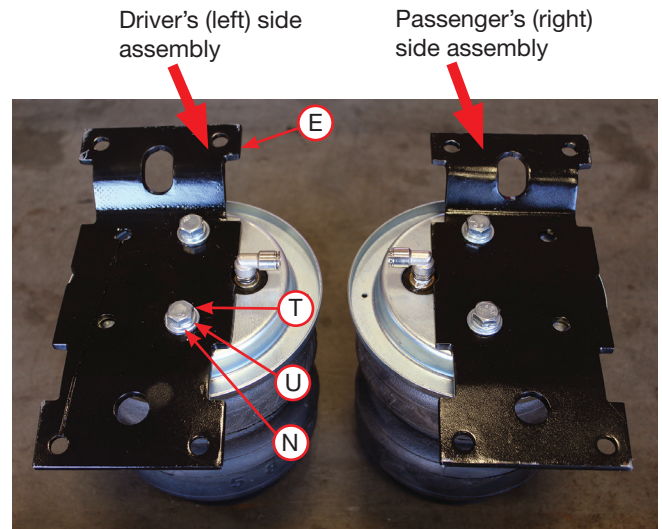

Fig. 9

- Flip the assemblies over and set a roll plate (F) onto the bottom of the air springs (Fig. 10).



Fig. 10

- Insert two 3/8"-16 X 10" carriage bolts (K) through the square holes in the lower bracket main plate (B) as shown. **For models with sway bars:** use the holes farthest away from the flanges for the left (driver's) side and the holes closest to the flanges for the right (passenger's) side installation (Fig. 11). **For all models without sway bars,** use the square holes farthest away from the flange for both sides of the installation.

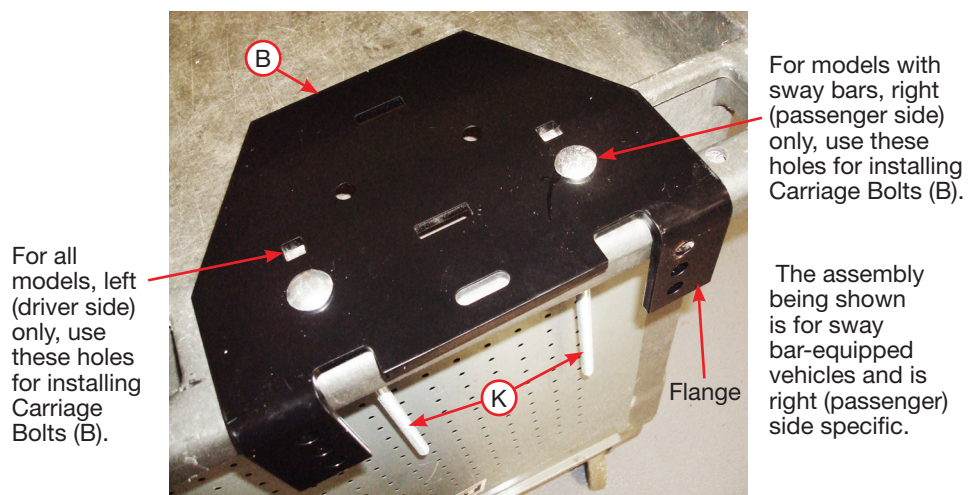

Fig. 11

- When installing the lower brackets onto the air spring assemblies already assembled (step 2, Fig. 9), if you have a sway bar-equipped vehicle, make sure the lower bracket assembly you assembled for the passenger's (right) side is assembled on the passenger's (right) side air spring assembly. Using the holes specified in step 4, for vehicles not equipped with sway bars, it will not matter which assembly the lower bracket fits on.

Set the lower bracket main plate assemblies onto the air springs with the roll plates installed. Attach with 3/8"-24 X 3/4" flat-head socket-cap screws (S) (Fig. 12). Torque the hardware to no more than 20 lbs.-ft. (27Nm).

NOTE *The flange on the lower bracket must be on the opposite side of the fitting that is located on the top of the air spring.*

The flanges on the lower bracket must be installed so they are on the opposite side of the fitting that is on the top of the air spring.

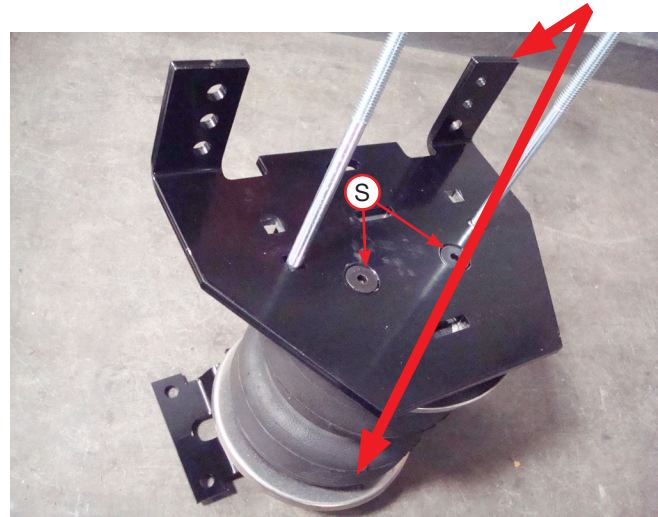

Fig. 12

- Install the lower bracket cup (C) onto the lower bracket main plate using the 5/16"-18 x 3/4" carriage bolt (L) (Fig. 13). Cap with 5/16"-18 serrated flange lock nut (M) (Fig. 14) Snug bolt down but leave loose enough for bracket to move freely in slot.

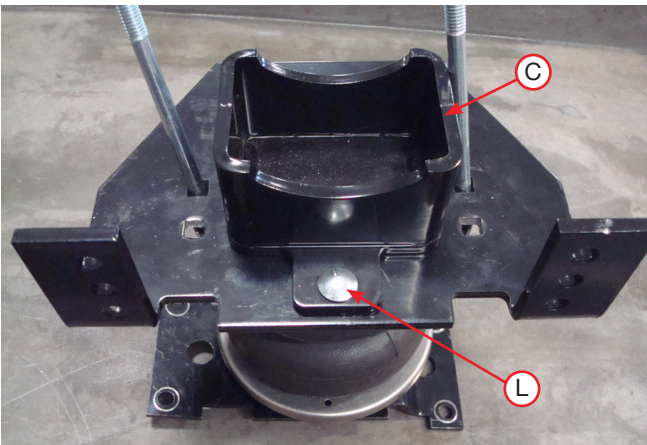

Fig. 13

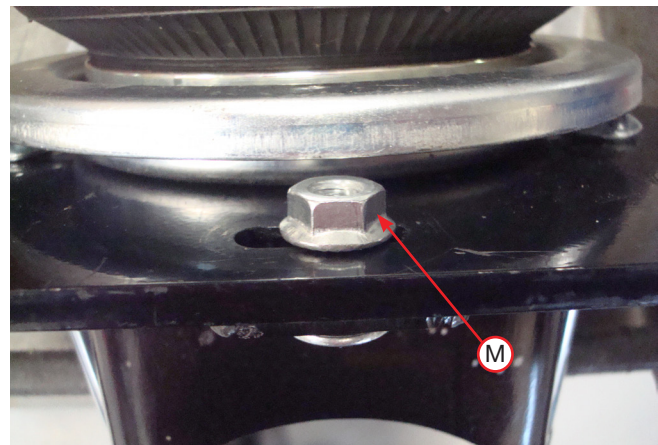

Fig. 14

- Figure 15 shows the driver's (left) side and passenger's (right) side assemblies.

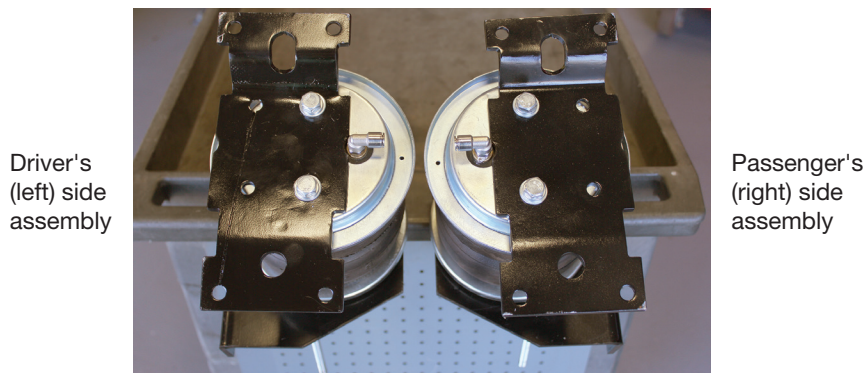

Fig. 15

INSTALLING THE AIR SPRING ASSEMBLIES

For 2023 and newer models with electronic rear brakes follow all steps in this section.

For 2022 and earlier models skip to step 4.

1. Remove the left-side wire harness from the axle bracket and secure it to the right-side wire harness, as shown in Figure 16.

NOTE

If there is a sway bar, insert the carriage bolts through the clamp bar (A) while setting the assemblies into position over the axle (see Fig. 20).

2. With the vehicle supported by safety stands, drop the axle or raise the body so that the assemblies can be put into position in between the axle and frame.
3. Install the U-bolt (H) around the leaf pack spacer (Fig. 17).



Fig. 16



Fig. 17

All Models:

4. Install the U-bolt through the middle holes on the bracket as you install the assembly onto the vehicle (Fig. 18).

NOTE

On the driver's (left) side, the long carriage bolt in the lower bracket main plate should be located between the hard brake line and axle (Fig. 23). On the passenger's (right) side, the carriage bolt should be located on the back-side of the brake line (Fig. 24).

5. Cap with the 3/8" flat washer (V) and 3/8" nylon lock nut (W) as shown in Figure 18. Snug bolts evenly, just enough to hold the lower bracket main plate flush against the stock U-bolts.

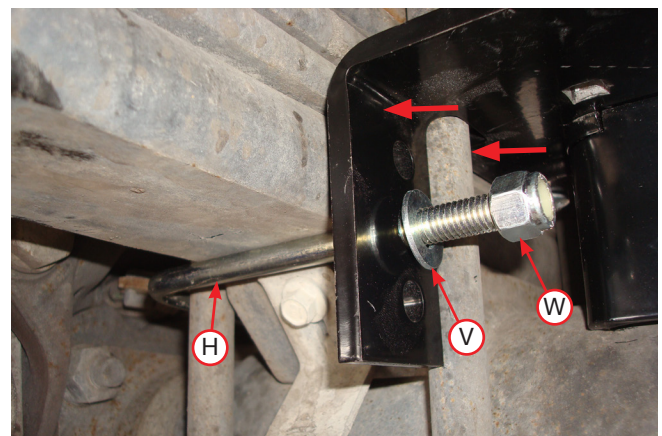
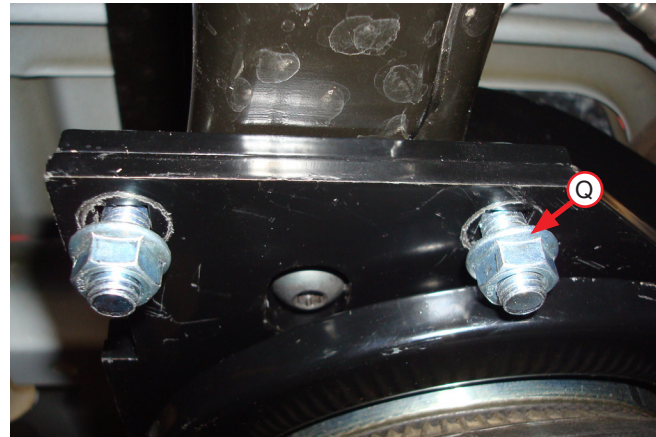

Fig. 18

- Before proceeding, ensure the 90-degree fittings each point inboard toward the center of the vehicle. While raising the axle or lowering the body of the vehicle, align the previously installed upper frame bracket carriage bolts with the air spring bracket holes so the carriage bolts protrude through the air spring bracket. Cap the carriage bolts with the 3/8" serrated flange lock nuts (Q) (Fig. 19). Snug the bolts down first then torque to 31 lb.-ft. (42Nm). Finish raising the axle or lowering the body and remove safety stands.

Fig. 19

- If not completed, set the lower clamp bars (A) over the carriage bolts located under the axle (Fig. 20). Attach with the 3/8" flat washers (V) and 3/8" nylon lock nuts (W). Evenly torque the lower clamp bar hardware to 16 lb.-ft. (22Nm). Finish tightening the U-bolt hardware previously snugged by torquing to 10 lb.-ft. (14Nm).

TECH TIP

For sway bar applications, it's acceptable to tighten the front carriage bolt hardware down more than the rear to gain more clearance on the sway bar. Also, it may be necessary to use a 9/16" crows foot adapter to properly torque the hardware.

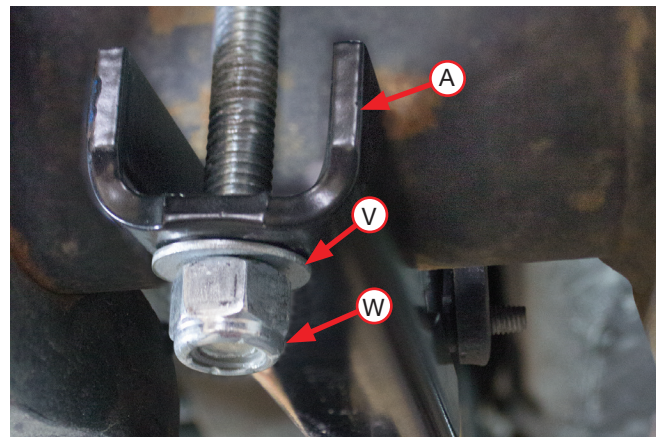
Fig. 20

- If necessary, on vehicles that have a sway bar, cut the front carriage bolt just below the nut so it does not contact the sway bar (Fig. 21).

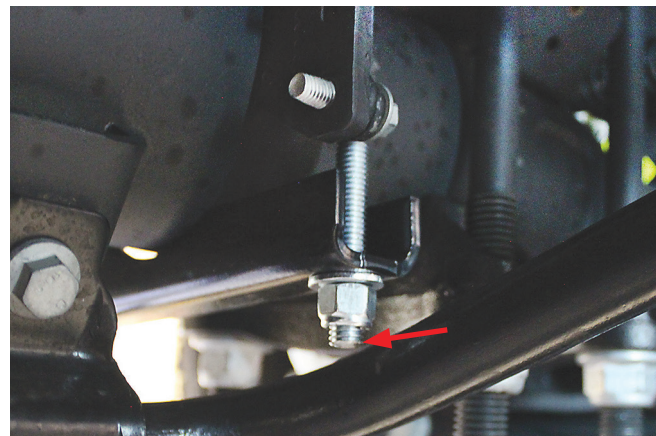
Fig. 21

- Snug the nut holding the lower bracket main plate and lower bracket cup together to finish the lower bracket installation (Fig. 22).



This nut will be difficult to tighten. It may be necessary to flip the wrench over a couple of times and/or move from the front/back side of the axle to get this tightened.

- Fig. 23 and Fig. 24 show the lower bracket installed.



PUSH THE HARD BRAKE LINE AWAY FROM THE LOWER BRACKET CARRIAGE BOLT IF THE LINE IS RESTING ON IT (FIG. 23 & FIG. 24).



Fig. 22

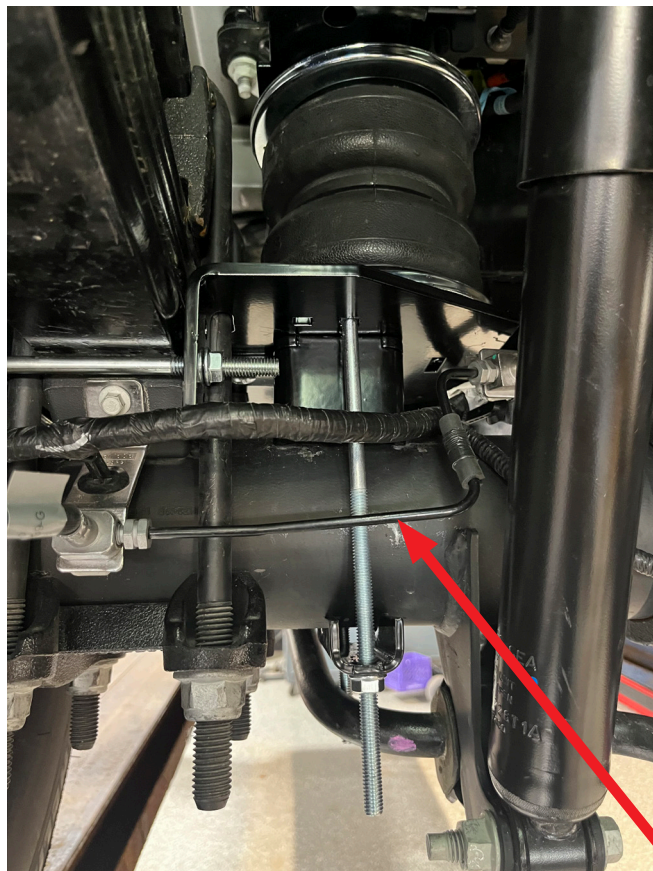

Fig. 23

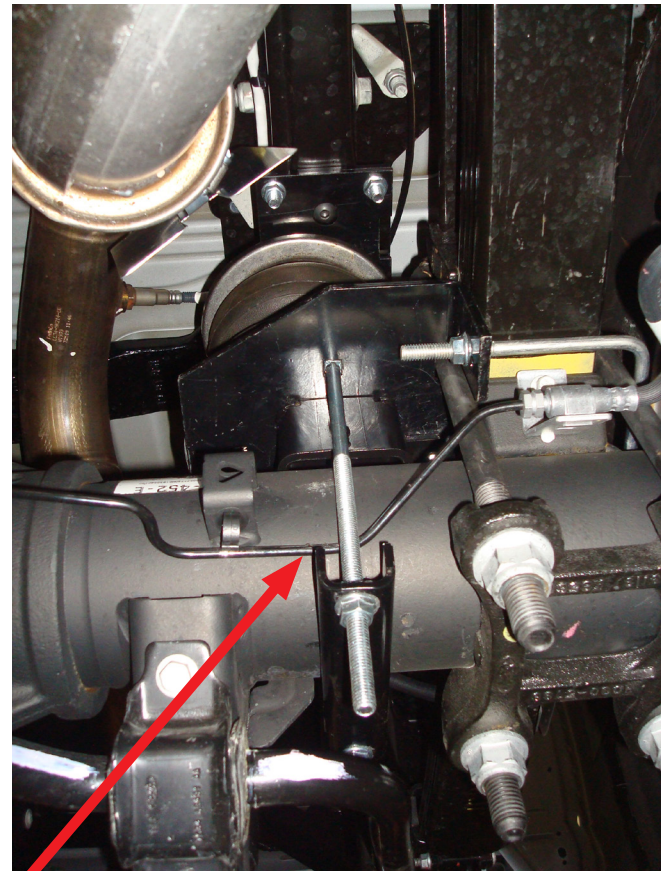
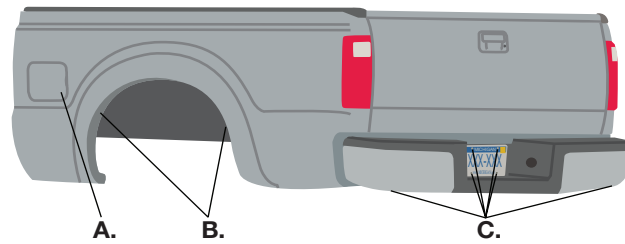

Fig. 24

If the hard brake line is resting on the lower bracket carriage bolts on either side, push or pull the brake line out of the way.

Installing the Air Lines

1. Choose the locations for the Schrader valves and drill a 5/16" (8mm) hole, if necessary.



A. Inside fuel tank filler door
 B. Inside rear wheel wells
 C. License plate or rear bumper area



KEEP AT LEAST 6" (152MM) OF CLEARANCE BETWEEN ALL AIR LINES AND THE EXHAUST SYSTEM. AVOID SHARP BENDS AND EDGES.

2. Make clean, square cuts with a razor blade or hose cutter when cutting the air line (AA). Do not use scissors or wire cutters.

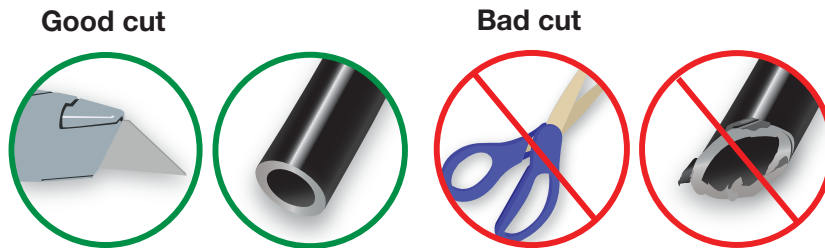

3. Use zip ties (BB) to secure the air line to fixed points along the chassis. Do not pinch or kink the air line. Leave at least 2" (51mm) of slack in the air line to allow for any movement that might pull on the air line. The minimum bend radius for the air line is 1" (25mm).

4. Install the Schrader valve in the chosen location.

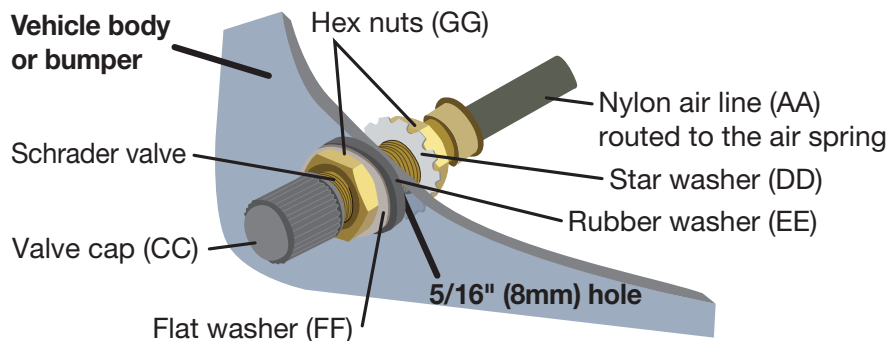

INSTALLING THE HEAT SHIELD

1. Attach the metal heat shield (II) to the exhaust pipe or exhaust resonator using the hose clamps (JJ, KK or both). Slide the air line thermal sleeve (HH) over the air line and place it where the air line is closest to the exhaust.

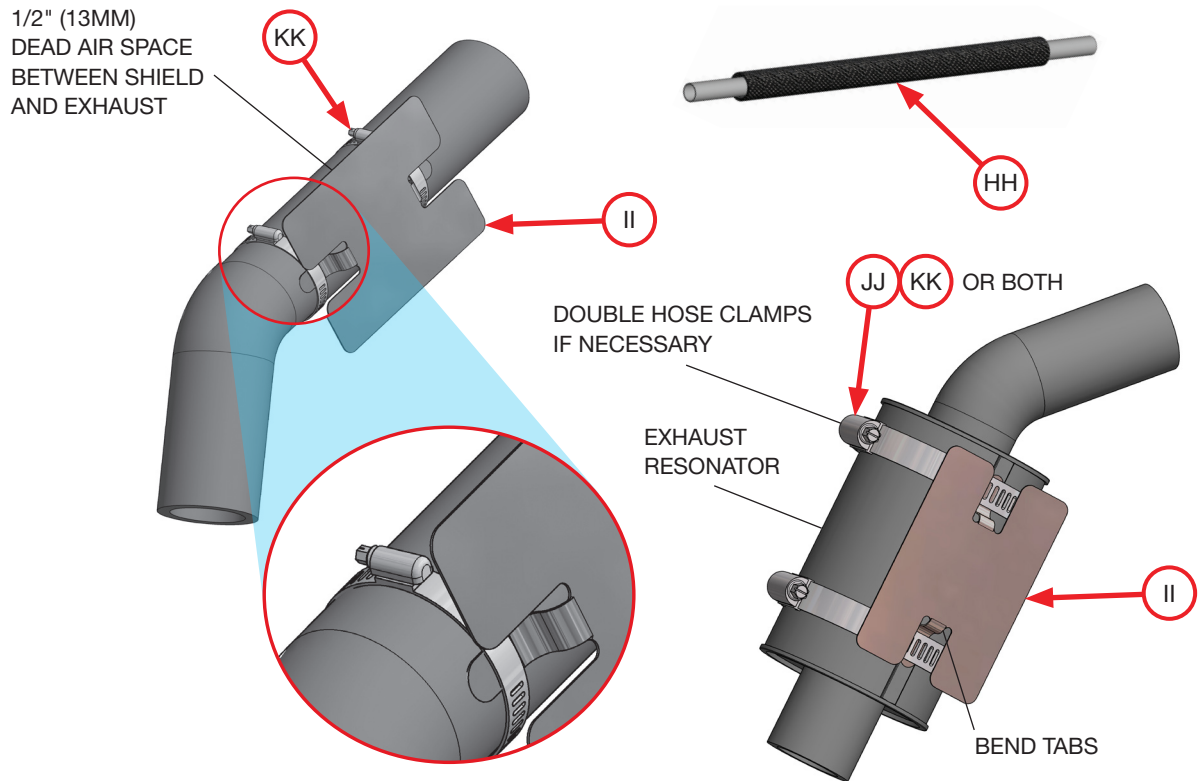

Finished Installation

This image shows the finished installation of the passenger's (right) side.

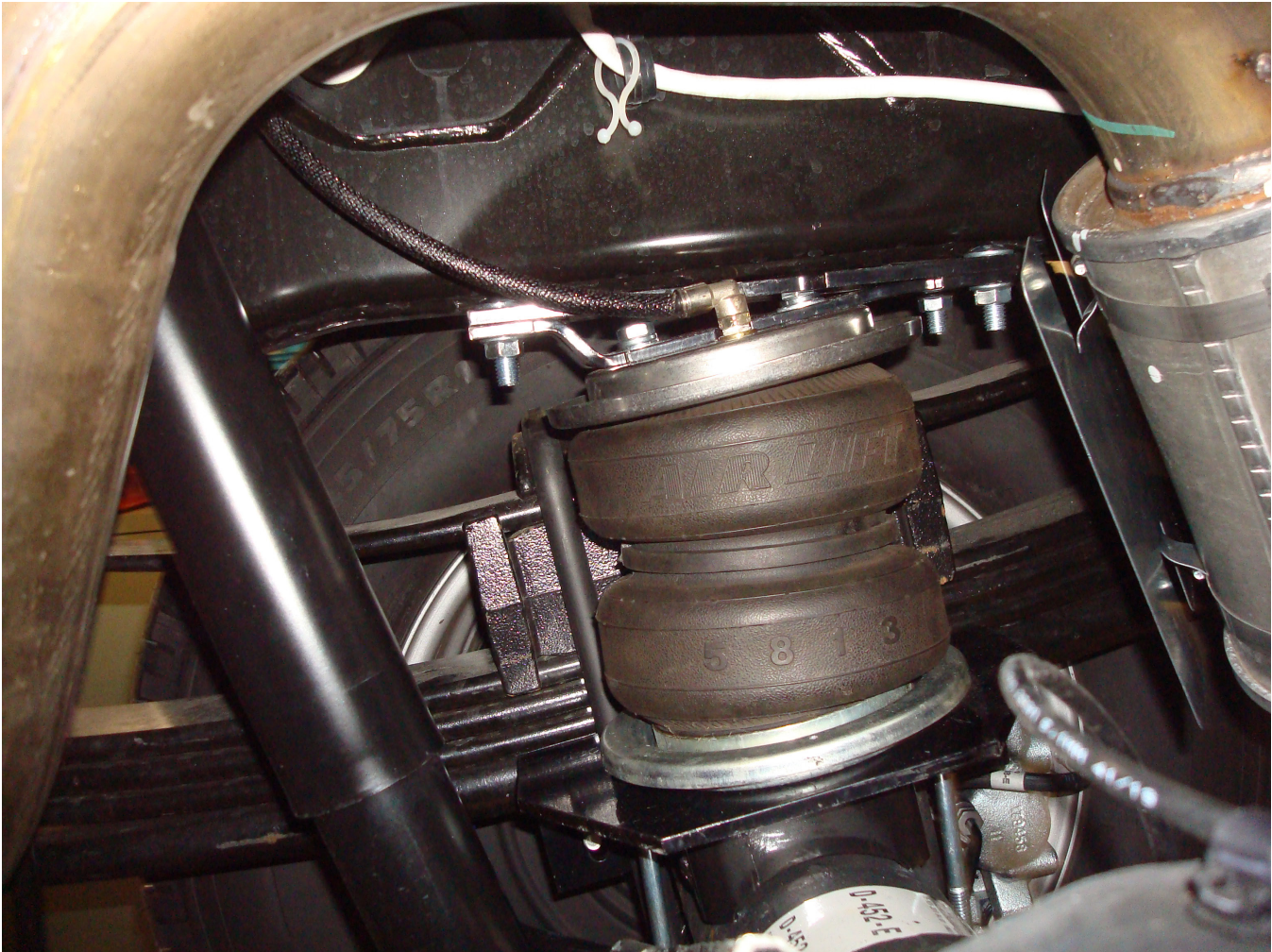

Congratulations!

You are now the proud owner of an Air Lift air suspension system. Enjoy!

Before Operating

INSTALLATION CHECKLIST

- ❑ **Clearance test** — Inflate the air springs to 40-60 PSI (2.8-4.1BAR) and make sure there is at least 1/2" (13mm) clearance from anything that might rub against each sleeve. Be sure to check the tire, brakes, frame, shock absorbers and brake cables.
- ❑ **Leak test before road test** — Inflate the air springs to 40-60 PSI (2.8-4.1BAR) and check all connections for leaks. All leaks must be eliminated before the vehicle is road-tested.
- ❑ **Heat test** — Be sure there is sufficient clearance from heat sources, at least 6" (152mm) for air springs and air lines. If a heat shield was included in the kit, install it. If there is no heat shield, but one is required, call Air Lift customer service at (800) 248-0892.
- ❑ **Fastener test** — After 500 miles (800km), recheck all bolts for proper torque.
- ❑ **Road test** — The vehicle should be road-tested after the initial tests. Inflate the air springs to recommended driving pressures. Drive the vehicle 10 miles (16km) and recheck for clearance, loose fasteners and air leaks.
- ❑ **Operating instructions** — If professionally installed, the installer should review the operating instructions with the owner. Be sure to provide the owner with all of the paperwork that came with the kit.

MAINTENANCE AND USE GUIDELINES

1. Check air pressure weekly.
2. Always maintain normal ride height. Never inflate beyond 100 PSI (7BAR).
3. If the system develops an air leak, use a soapy water solution to check all air line connections and the inflation valve core before deflating and removing the air spring.
4. Upon successful completion of the installation, follow these pressure requirements for the air springs.



**Minimum Recommended
Air Pressure**



Maximum Air Pressure



FOR SAFETY AND TO PREVENT POSSIBLE DAMAGE TO THE VEHICLE, DO NOT EXCEED MAXIMUM GROSS VEHICLE WEIGHT RATING (GVWR) OR PAYLOAD RATING, AS INDICATED BY THE VEHICLE MANUFACTURER.

ALTHOUGH THE AIR SPRINGS ARE RATED AT A MAXIMUM INFLATION PRESSURE OF 100 PSI (7BAR), THE AIR PRESSURE ACTUALLY NEEDED IS DEPENDENT ON LOAD AND GROSS VEHICLE WEIGHT RATING.



Limited Warranty and Return Policy

Air Lift Company provides a Limited Lifetime Warranty* to the original purchaser of its load support products, from the date of original purchase, that the products will be free from defects in workmanship and materials when used on cars and trucks as specified by Air Lift Company and under normal operating conditions, subject to the requirements and exclusions set forth in the full Limited Warranty and Return Policy.

*Full Limited Warranty and Return Policy are available at www.airliftcompany.com/warranty and are subject to change.

WARRANTY REGISTRATION & CLAIMS

- To register your warranty, please visit <https://www.airliftcompany.com/support/warranty/register/>
- To submit a warranty claim, please visit <https://www.airliftcompany.com/support/warranty/submit-claim/>



Thank you for purchasing Air Lift Products!

Need Help?

Contact Air Lift Company Customer Service at (800) 248-0892
or email service@airliftcompany.com.

For calls outside the U.S. or Canada, dial +1 (517) 322-2144.



MADE IN USA
WITH GLOBAL
COMPONENTS

Air Lift Company • 2727 Snow Road • Lansing, MI 48917 or P.O. Box 80167 • Lansing, MI 48908-0167

Air Lift Company reserves the right to make changes and improvements to its products and publications at any time.
For the latest version of this manual, contact Air Lift Company at (800) 248-0892 or visit airliftcompany.com.