

**07-12 CHEVY TRAVERSE/GMC ACADIA/07-10 SATURN OUTLOOK/07-09 BUICK ENCLAVE
(EXCL. 2010-11 BUICK ENCLAVE)**

PARTS LIST:

1	Driver/Left Sidebar	6	12mm Lock Washers
1	Passenger/Right Sidebar	6	12mm ID x 32mm OD x 3mm Flat Washers
1	Driver/Left Front Mounting Bracket	6	12mm Hex Nuts
1	Passenger/Right Front Mounting Bracket	4	10mm Lock Washers
1	Driver/Left Rear Mounting Bracket	4	10mm x 27mm OD x 3mm Flat Washers
1	Passenger/Right Rear Mounting Bracket	4	10mm Hex Nuts
2	"Z" Brackets W/Welded 8mm Hex Nuts	12	8-1.25mm x 25mm Hex Bolts
6	12-1.75mm x 45mm Bolt Plates	12	8mm Lock Washers
4	10-1.5mm x 35mm Button Head Bolt Plates	10	8mm ID x 24mm OD x 2mm Flat Washers
6	12mm Square Washers		

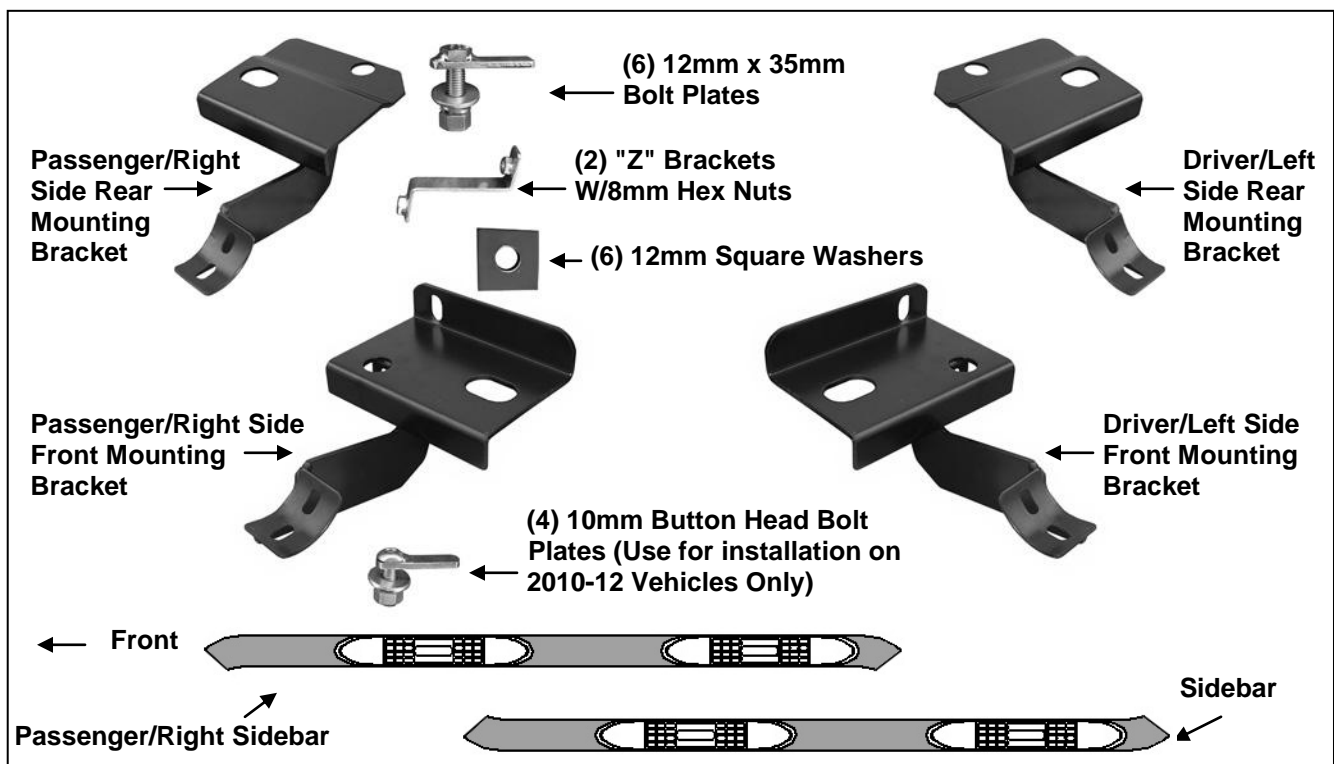

PROCEDURE:

- REMOVE CONTENTS FROM BOX. VERIFY ALL PARTS ARE PRESENT. READ INSTRUCTIONS CAREFULLY BEFORE STARTING INSTALLATION.**
NOTE: The factory may spray excess foam on the floor panel you may need to scrap foam away from holes to allow bolt plates to fit into holes & work correctly.
- Start installation on the passenger side and locate the factory holes in the bottom and side of the floor panel towards the front of the vehicle.
 - On 2007-09 Vehicles:** There is an oval hole and a round hole on the bottom of the floor panel and a round hole on the side of the floor panel. Insert (1) 12mm x 45mm Bolt Plate into the oval hole and turn the Bolt Plate 90-degees so that the plate is across opening, **(Figures 1 & 3B)**.
 - On 2010-11 Vehicles:** There are two round holes on the bottom of the floor panel, (one centered, one offset toward the pinch weld), and one round hole on the side of the floor panel. Insert (1) 10mm x 35mm Button Head Bolt Plate into the round hole in the center of the floor panel **(Figures 2 & 4B)**. Make sure that the plate is supported across the hole in the floor panel.
- Next, select (1) 8mm "Z" Bracket, **(Figure 1B)**. Insert the end with the hex nut welded onto the outside of the Bracket into the round hole in the bottom of the floor panel. Maneuver the "Z" Bracket through the inside of the floor panel and line it up to the hole in the side of the floor panel, **(Figures 1A, 2 & 6)**.

**07-12 CHEVY TRAVERSE/GMC ACADIA/07-10 SATURN OUTLOOK/07-09 BUICK ENCLAVE
(EXCL. 2010-11 BUICK ENCLAVE)**

4. Position the passenger side front Mounting Bracket up to the vehicle and over the previously installed Bolt Plate and "Z" Bracket. **NOTE:** The hole pattern on the Mounting Bracket will match up with the hole pattern on the floor panel. Bolt the Mounting Bracket to the Bolt Plate using the included hardware.
 - a. **On 07-09 Vehicles:** Use (1) 12mm Square Washer, (1) 12mm Lock Washer and (1) 12mm Hex Nut to secure the Bracket to the Bolt Plate, **(Figure 3A)**. Do not tighten hardware at this time.
 - b. **On 2010-12 Vehicles:** Use (1) 12mm Square Washer, (1) 10mm Flat Washer, (1) 10mm Lock Washer and (1) 10mm Hex Nut to secure the Bracket to the 10mm Bolt Plate, **(Figure 4A)**. Do not tighten hardware at this time.
5. Insert (1) 8mm x 25mm Hex Bolt, (1) 8mm Lock Washer, and (1) 8mm Flat Washer through the Mounting Bracket, the side of the floor panel and into the nut on the "Z" Bracket, **(Figures 3 & 4)**. Attach the remaining end of the "Z" Bracket to the tab on the bottom of the Mounting Bracket using the included (1) 8mm x 25mm Hex Bolt and (1) 8mm Lock Washer, **(Figures 4 - 6)**. Snug but do not fully tighten hardware at this time.
6. Move toward the rear of the vehicle and locate the round or oval hole centered in the bottom of the floor panel as described in **Step 2, (Figures 7 & 8)**.
 - a. **07-09** vehicles are equipped with an oval hole in the center of the floor panel as described in **Step 2a**. Insert (1) 12mm x 45mm Bolt Plate into the oval hole in the center of the floor panel and turn 90-degees across the oval hole, **(Figure 7)**.
 - b. **2010-12** vehicles are equipped with a round hole in the center of the floor panel as described in **Step 2b**. Insert (1) 10mm x 35mm Bolt Plate into the round hole in the center of the floor panel, **(Figure 8)**.
7. Next, locate the large hole slightly in toward the center of the vehicle from the previously installed Bolt Plate. **NOTE:** Use the passenger side Rear Bracket to determine the correct mounting hole to use. Insert (1) 12mm x 45mm Bolt Plate into the factory hole, **(Figures 7 & 8)**. **NOTE:** Do not center the Bolt Plate in the hole, the shorter end of the Bolt Plate should be pushed to one side of the factory hole in order to fully engage.
8. Hold the passenger side Rear Mounting Bracket up to the vehicle and over the previously inserted Bolt Plates. Secure Mounting Bracket to the Bolt Plates using the included hardware.
 - a. **On 07-09 Vehicles:** Use (1) 12mm Square Washer, (1) 12mm Lock Washer and (1) 12mm Hex Nut to secure the Bracket to the Bolt Plate in the oval hole, **(Figure 9)**. Use (1) 12mm Flat Washer, (1) 12mm Lock Washer and (1) 12mm Hex Nut to secure the Bracket to the Bolt Plate in the round hole. Do not tighten hardware at this time.
 - b. **On 2010-11 Vehicles:** Use (1) 12mm Square Washer, (1) 10mm Flat Washer, (1) 10mm Lock Washer and (1) 10mm Hex Nut to secure the Bracket to the 10mm Bolt Plate in center of the floor panel, **(Figure 10)**. Use (1) 12mm Flat Washer, (1) 12mm Lock Washer and (1) 12mm Hex Nut to secure the Bracket to the Bolt Plate in the round hole. Do not tighten hardware at this time.
9. Carefully position the passenger Sidebar onto the Mounting Brackets. Bolt the Sidebar to the Mounting Brackets with the included (4) 8mm x 25mm Hex Bolts, (4) 8mm Lock Washers and (4) 8mm Flat Washers, **(Figure 11)**.
10. Level and adjust the Sidebar properly and tighten all hardware at this time. **IMPORTANT!** Do not move the Mounting Brackets too much when adjusting the Sidebar; this may cause Bolt Plates to disengage from the factory holes.
11. Repeat Steps 2 – 10 for driver Sidebar installation.
12. Do periodic inspections to the installation to make sure that all hardware is secure and tight.

To protect your investment, wax this product after installing. Regular waxing is recommended to add a protective layer over the finish. Do not use any type of polish or wax that may contain abrasives that could damage the finish.

For stainless steel: Aluminum polish may be used to polish small scratches and scuffs on the finish. Mild soap may be used also to clean the Sidebar.

For gloss black finishes: Mild soap may be used to clean the Sidebar.

07-12 CHEVY TRAVERSE/GMC ACADIA/07-10 SATURN OUTLOOK/07-09 BUICK ENCLAVE
(EXCL. 2010-11 BUICK ENCLAVE)

Passenger Side Installation Pictured

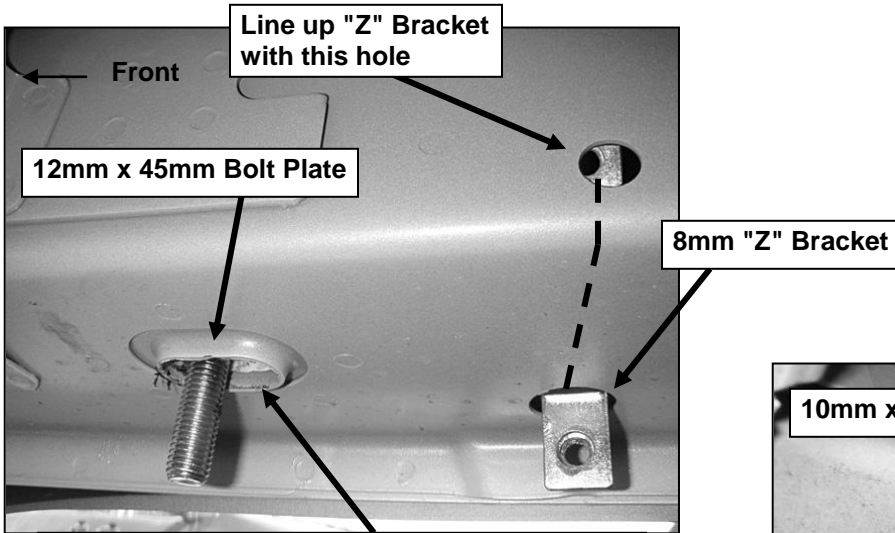

(Fig 1A) 07-09 Model Pictured-Note Oval Hole

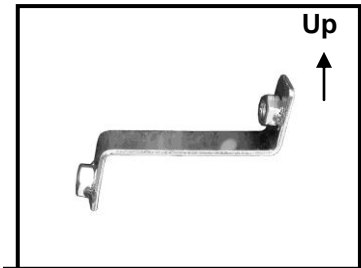

(Fig 1B) 8mm "Z" Bracket

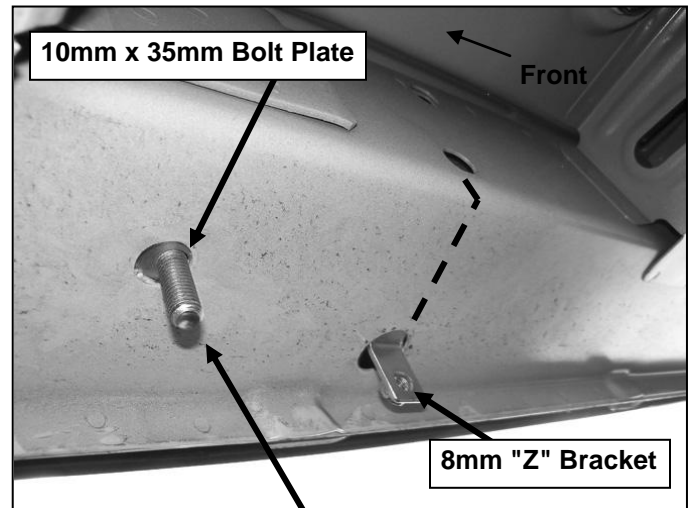

(Fig 2) 2010-11 Model Pictured-Note Round Hole

- 12mm x 45mm Bolt Plate
- 12mm Square Washer
- 12mm Lock Washer
- 12mm Hex Nut
- 8mm x 25mm Hex Bolt
- 8mm Lock Washer
- 8mm Flat Washer

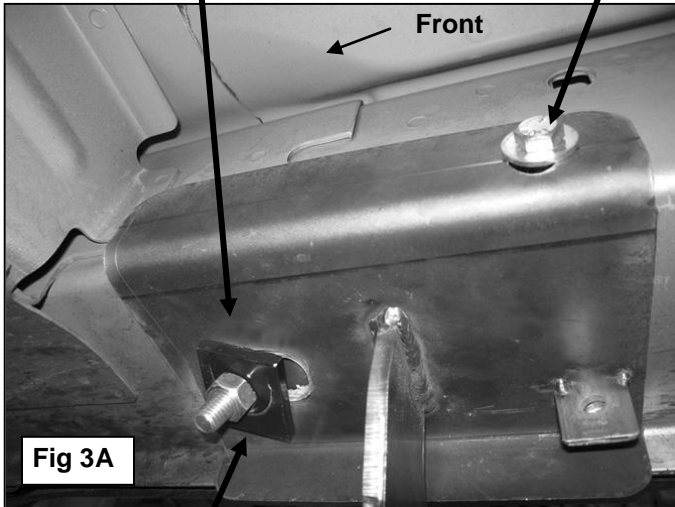
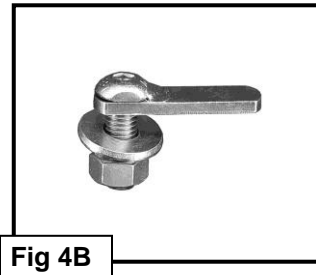
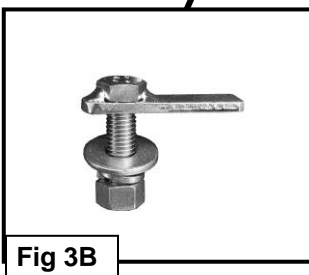

Fig 3A



- 10mm x 35mm Bolt Plate
- 12mm Square Washer
- 10mm Flat Washer
- 10mm Lock Washer
- 10mm Hex Nut
- 8mm x 25mm Hex Bolt
- 8mm Lock Washer
- 8mm Flat Washer

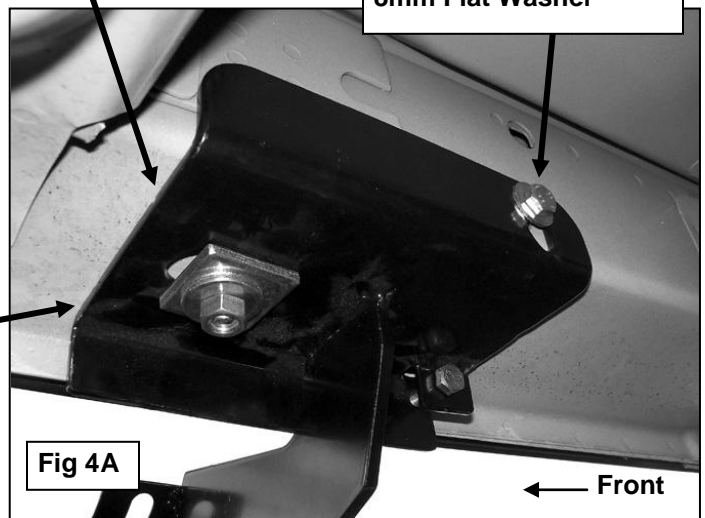
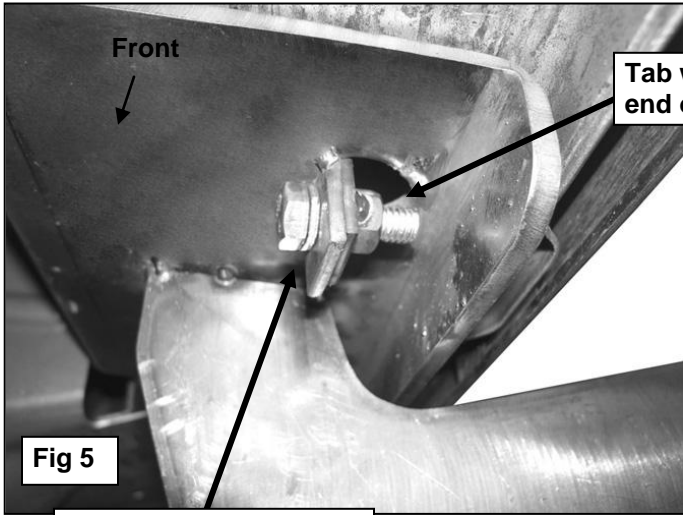

Fig 4A

07-12 CHEVY TRAVERSE/GMC ACADIA/07-10 SATURN OUTLOOK/07-09 BUICK ENCLAVE
(EXCL. 2010-11 BUICK ENCLAVE)

Passenger Side Installation Pictured



8mm x 25mm Hex Bolt
8mm Lock Washer



12mm x 45mm Bolt Plate

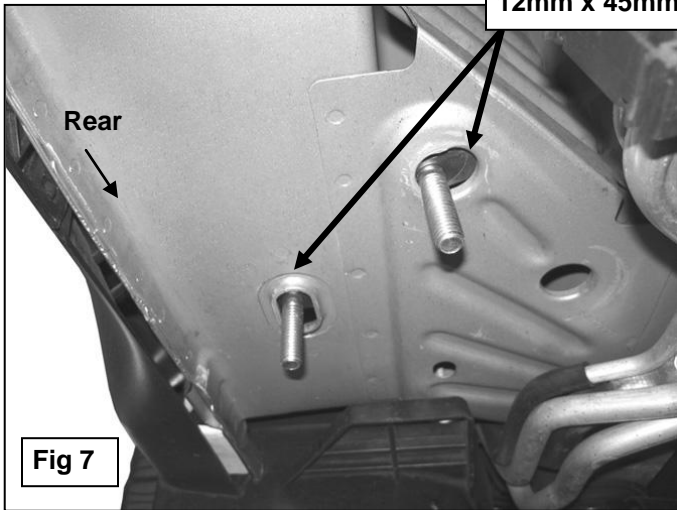
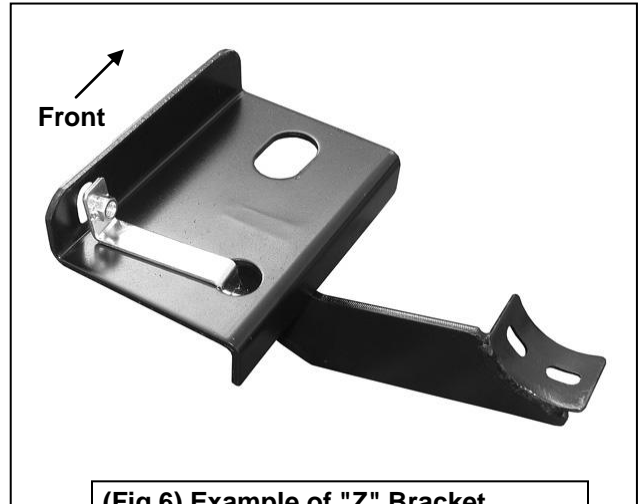

10mm x 35mm Bolt Plate

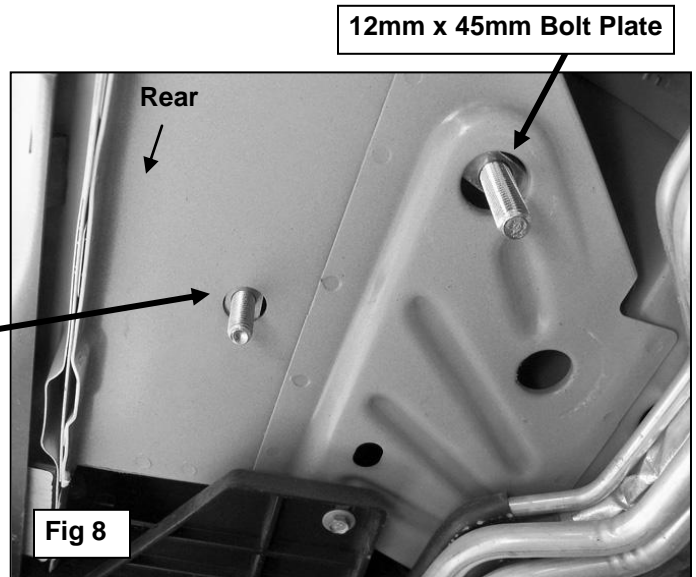

07-12 CHEVY TRAVERSE/GMC ACADIA/07-10 SATURN OUTLOOK/07-09 BUICK ENCLAVE
(EXCL. 2010-11 BUICK ENCLAVE)

Passenger Side Installation Pictured

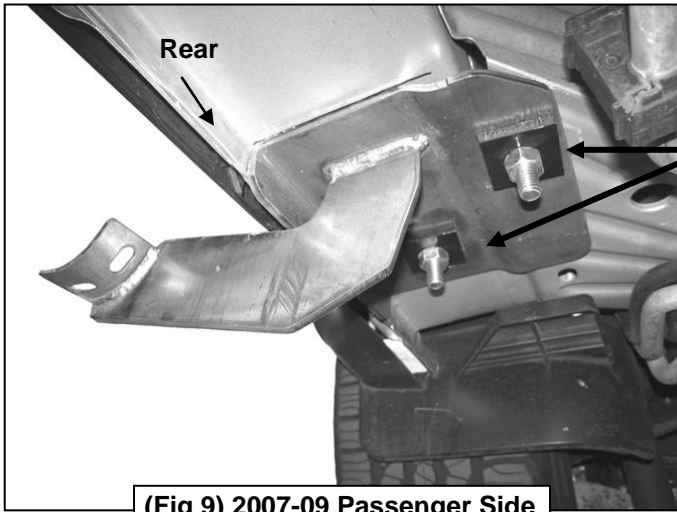

(Fig 9) 2007-09 Passenger Side Rear Installation Pictured

12mm x 45mm Bolt Plate
12mm Square Washer
12mm Lock Washer
12mm Hex Nut

10mm x 35mm Bolt Plate
12mm Square Washer
10mm Flat Washer
10mm Lock Washer
10mm Hex Nut

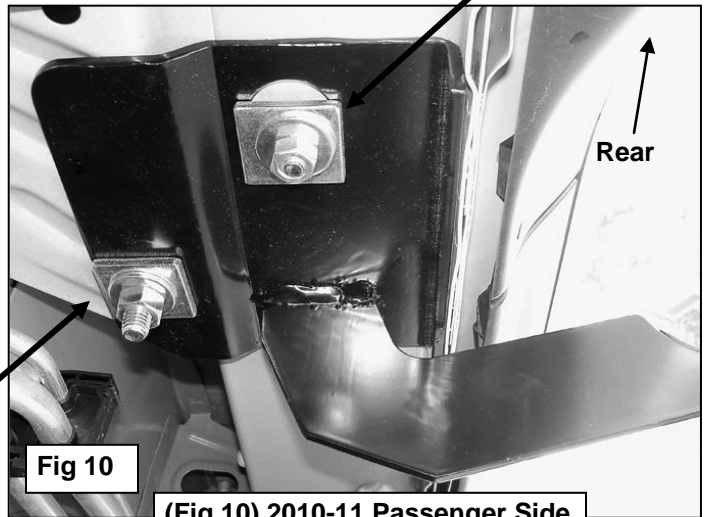

Fig 10

(Fig 10) 2010-11 Passenger Side Rear Installation Pictured

12mm x 45mm Bolt Plate
12mm Square Washer
12mm Lock Washer
12mm Hex Nut

8mm x 25mm Hex Bolt
8mm Lock Washer
8mm Flat Washer

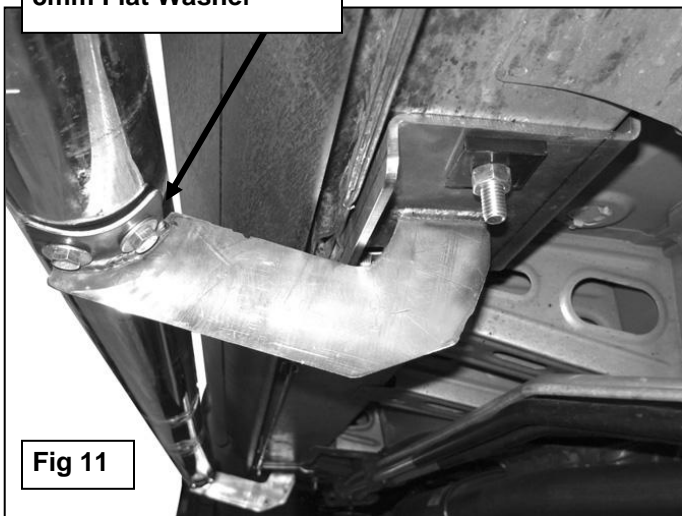

Fig 11