

SumoSprings Rear

Ford F250 & F350, 2WD, 2011-2016

Part #SSR-133-40-2 & SSR-133-47-2

DRIVER'S SIDE FRONT →

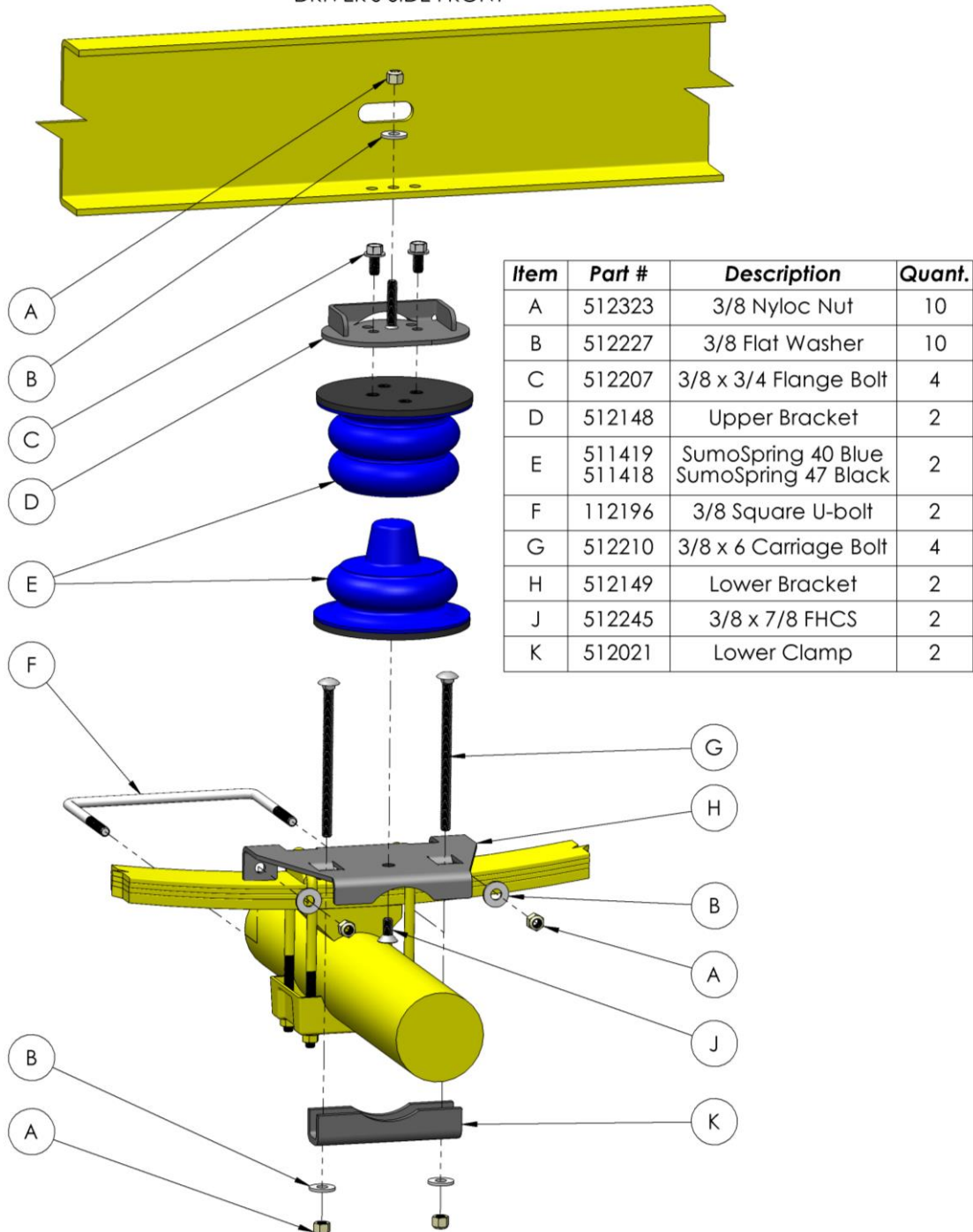

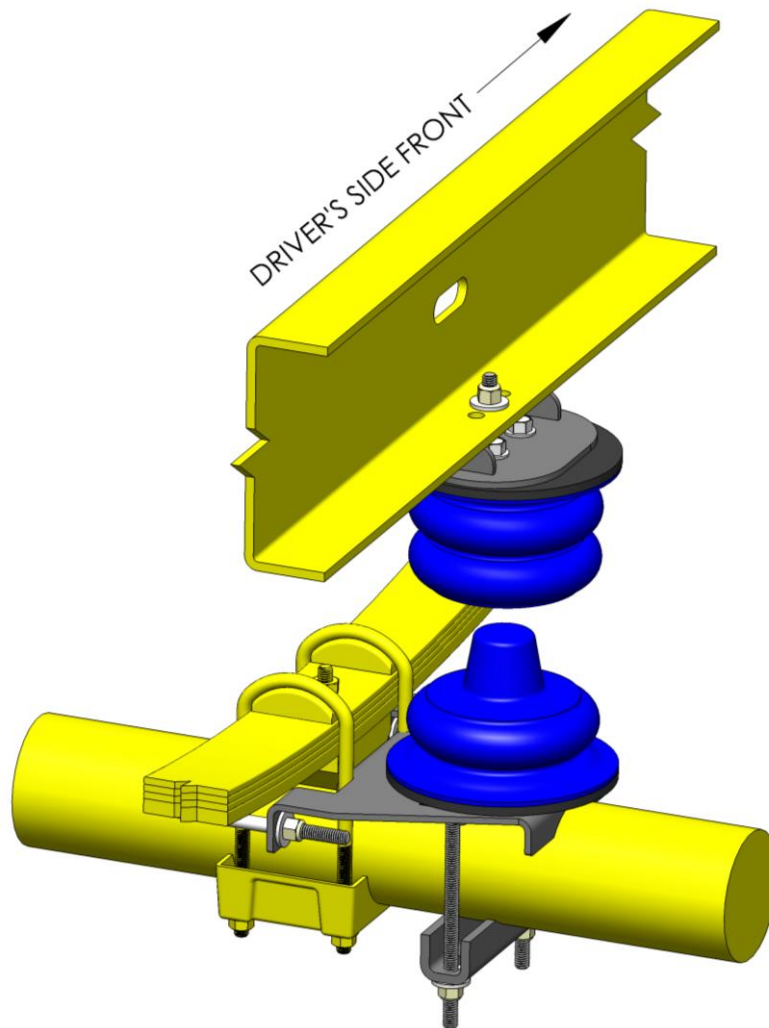

Installation Instructions

- 1) Park vehicle on level hard surface. Place wheel blocks in front and behind the front wheels to prevent rolling. Observe all safety precautions and wear safety glasses.
- 2) Raise the rear of the vehicle allowing the axle to hang free and rest the frame on the safety jack stands rated for the weight of the vehicle. Removal of the rear wheels is optional.
- 3) Starting on the driver's side un-bolt and remove the factory jounce bumper from the underside of the frame.
- 4) Attach Upper Bracket (Item D) to the top of the SumoSprung (Item E) using two 3/8 x 3/4 Flange Bolts (Item C). Place a drop of the blue locktite on the threads of each bolt and torque to 30 ft. lbs. Be sure to use the set of holes in the bracket that locate the SumoSprung further inboard.
- 5) Attach the SumoSprung with Upper Bracket to the bottom of the frame. Ensure proper orientation with SumoSprung offset inboard (away from the wheel). Insert mounting stud of upper bracket into the hole in the frame where the factory bump stop was removed. Fasten securely using one 3/8 flat washer (Item B) and one 3/8 Nyloc nut (Item A).
- 6) Place two 3/8 carriage bolts (Item G) in the recessed holes of the lower bracket (Item H).
- 7) Attach Lower Bracket (Item H) to bottom half of SumoSprung (Item E) using one 3/8 FHCS (Item J). Place a drop of the blue locktite on the threads and torque to 30 ft. lbs.
- 8) Place the Lower Bracket and bottom half of SumoSprung on top of the axle.

- 9) Place the square u-bolt (Item F) around the factory u-bolts as shown and attach to the tabs on the lower bracket using the 3/8 Nyloc nuts (Item A) and 3/8 flat washers (Item B). Tighten the nuts snugly, but do not over tighten or the bracket could be damaged.
- 10) Place the lower clamp bracket (Item K) onto the ends of the carriage bolts (Item G).
- 11) Secure in place using the 3/8 Nyloc nuts (Item A) and 3/8 flat washers (Item B). Tighten the nuts snugly, but do not over tighten or the bracket could be damaged.
- 12) Once upper and lower components are in place, raise the axle with the jack so the weight of the truck is again on the suspension.
- 13) Confirm that the upper and lower halves of the SumoSprings are aligned within 1/2". It is normal for them to engage at a bit of an angle and this will not affect the operation of the SumoSprings.
- 14) Repeat steps 3-13 on passenger side of truck.
- 15) If rear wheels were removed you can now reinstall the rear wheels and torque wheel nuts to manufacturers spec.
- 16) Jack up the vehicle and remove the safety jack stands.
- 17) Remove wheel blocks from the front wheels.
- 18) Fill out warranty card and send to SuperSprings.

Important Notice.

- 1) For easy installation please read instructions completely first and have all necessary tools available.
- 2) We recommend that this installation be done by a professional or persons with sound mechanical knowledge.
- 3) SumoSprings are designed to work with the original factory springs only. If they have been replaced with aftermarket springs then please consult with Supersprings International at 866-898-0720.
- 4) These instructions are meant as a guide for the installation of SumoSprings. SuperSprings International assumes no liability for the actual installation process. Installers should apply common automotive safety practices when raising, lowering and working on vehicles.
- 5) SumoSprings are designed to enhance the vehicles load carrying performance and road handling however it does not authorize (or recommend) loading beyond the manufacturer's GVWR specifications.
- 6) For technical support contact SuperSprings International at 866-898-0720.

To prevent damage to the vehicle and to ensure safety, do not exceed the maximum load recommended by the vehicles manufacturer (GVWR).