

PART NUMBER

SSR-143-40-2

IMPORTANT NOTICE: Your part may have been loosley preassembled to show the final product as it will be once installed on your vehicle. Please disassemble the product before proceeding to the installation.

BEFORE YOU BEGIN

APPLICATION

- › Ford F150 2WD (2015-present)
- › Ford F150 4WD (2015-present)

PLEASE NOTE:

This part will *not* work on Raptor models.

TOOLS REQUIRED

- › Floor jack
- › Safety jack stands
- › Ratchet and sockets
- › Torque wrench

PARTS LIST

Item	Part #	Description	QTY
A	511419	Blue SumoSPrings -40	2
B	512164	Upper bracket A (passenger side)	1
B	512163	Upper bracket A (driver side)	1
C	512165	Upper bracket B	2
D	512166	Lower bracket (passenger side)	1
D	512167	Lower bracket (driver side)	1
E	512168	3/8" tag nut	4
F	112183	3/8" u-bolt	4
G	512302	3/8" locking flange nut	16
H	512278	3/8 x 1-1/2" flange bolt	12
I	512207	3/8 x 3/4" flange bolt	6
J	512248	3/8" fender washer	4

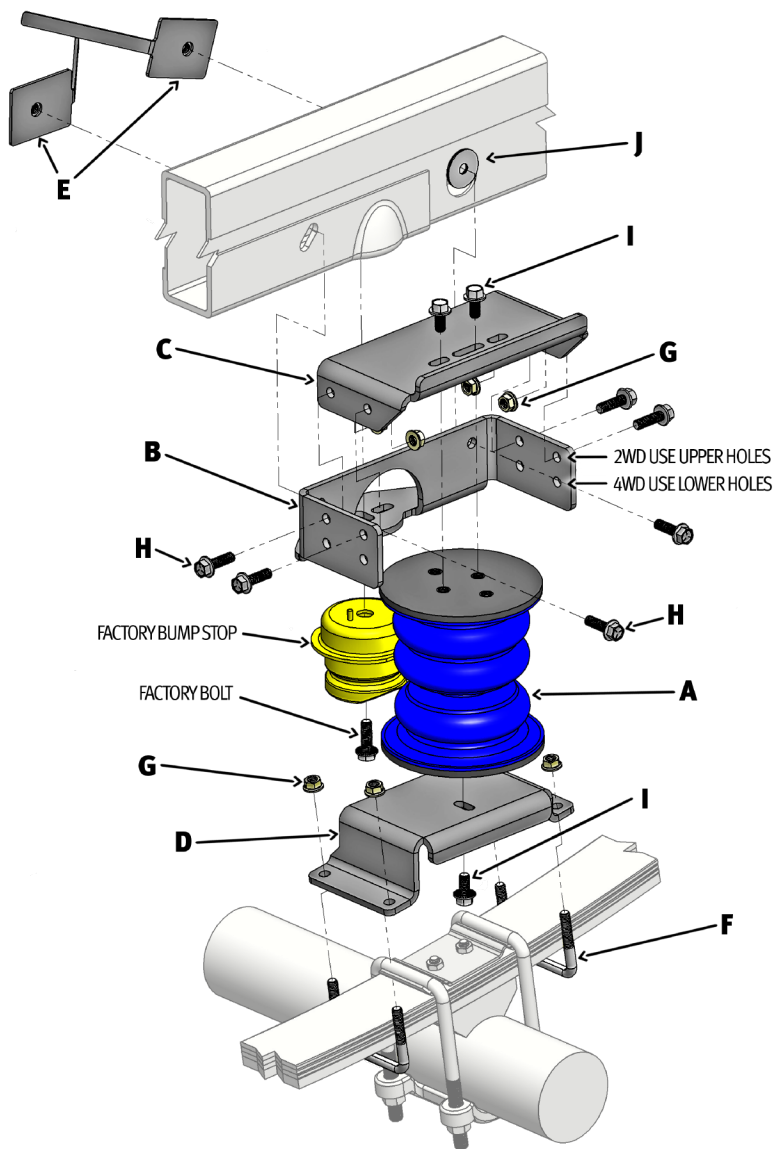

DRIVER SIDE (PASSENGER SIDE SIMILAR)

Part Number: SSR-143-40-2

› Product Line: SUMOSPRINGS REAR

Page 1

SuperSprings International, Inc.

505 Maple Avenue
Carpenteria, CA 93013

Installation Support

+1 (800) 898-0705
support@supersprings.com

supersprings.com

SAFETY NOTICE: We recommend installation be done by a professional or persons with sound mechanical knowledge.

WARNING: These instructions are a general guide for installation. SuperSprings International, Inc. assumes no liability for the actual installation process. Consumers and installers should apply common automotive safety practices when raising and working on any vehicle. **Do not put yourself in a position where, if the vehicle were to move unexpectedly, you may be injured.** SuperSprings' products are designed to improve vehicle ride quality. Do not load any vehicle beyond the manufacturer's specifications.

Never exceed the manufacturer's Gross Vehicle Rating (GVWR) located on your vehicles identification tag.

BEFORE INSTALLATION: Ensure the vehicle is on a level surface, the parking brake is ON, with the ignition OFF, and place blocks in front of and behind the front tires to prevent the vehicle from moving.

DURING AND/OR AFTER INSTALLATION: Ensure emergency brake cables are not touching the SuperSprings. Secure any cables out of the way with zip ties or by re-routing. **Ensure all A/C lines, brake cables, and frame are clear of contact or interference.**

PART NUMBER

SSR-143-40-2

INSTALLATION

1. Park the vehicle on a hard, level surface and engage the emergency brake. Place blocks in front and behind wheels to prevent rolling. Observe all safety precautions and wear safety glasses.
2. Raise the rear of the vehicle allowing the axle to hang free and rest the frame on the safety jack stands rated for the weight of the vehicle. Removal of the rear wheels is optional.
3. Starting on the driver side, remove the factory bump stops from the underside of the frame.
4. Take two of the 3/8" tag nuts [ITEM E] and bend the tangs up at about a 45 degree angle. Place them through the oval hole on the inside of the frame rail.
5. Attach the driver's side upper bracket A [ITEM B] to the bottom of the frame rail using the factory bump stop and bolt, but leave it loose for now.
6. Place two of the 3/8" fender washers [ITEM J] behind the rear hole of the upper bracket.
7. Insert one 3/8 x 1-1/2" flange bolt [ITEM H] through the rear hole of the bracket, the two fender washers, and the large hole in the frame. Thread the bolt into the 3/8" tag nut and fasten until finger-tight.
8. Insert one 3/8 x 1-1/2" flange bolt [ITEM H] through the front hole of the bracket and through the hole in the frame. Thread the bolt into the 3/8" tag nut and fasten until finger-tight.
9. Torque the two mounting bolts and the bump stop bolt to 25 ft. lbs.
10. Fasten the upper bracket B [ITEM C] to the top half of the SumoSpring [ITEM A] using two 3/8 x 3/4" flange bolts [ITEM I] through the forward two slots in the bracket and fasten until finger-tight.
11. Attach the upper bracket B [ITEM C] to the upper bracket A [ITEM B] using four 3/8 x 1-1/2" flange bolts [ITEM H] and 3/8" locking flange nuts [ITEM G]. Use a torque wrench to tighten the bolts to to 25 ft. lbs.
NOTE: 2WD trucks use the upper set of holes and 4WD trucks use the lower set of holes.
12. Attach the lower bracket 512167 [ITEM D] to the bottom half of the SumoSpring [ITEM A] with one 3/8 x 3/4" flange bolt [ITEM I] and fasten until finger-tight.

Part Number: SSR-143-40-2

► Product Line: SUMOSPRINGS REAR

Page 2

**SuperSprings
International, Inc.**

505 Maple Avenue
Carpenteria, CA 93013

Installation Support

+1 (800) 898-0705
support@supersprings.com

supersprings.com

SAFETY NOTICE: We recommend installation be done by a professional or persons with sound mechanical knowledge.

WARNING: These instructions are a general guide for installation. SuperSprings International, Inc. assumes no liability for the actual installation process. Consumers and installers should apply common automotive safety practices when raising and working on any vehicle. **Do not put yourself in a position where, if the vehicle were to move unexpectedly, you may be injured.** SuperSprings' products are designed to improve vehicle ride quality. Do not load any vehicle beyond the manufacturer's specifications.

Never exceed the manufacturer's Gross Vehicle Rating (GVWR) located on your vehicles identification tag.

BEFORE INSTALLATION: Ensure the vehicle is on a level surface, the parking brake is ON, with the ignition OFF, and place blocks in front of and behind the front tires to prevent the vehicle from moving.

DURING AND/OR AFTER INSTALLATION: Ensure emergency brake cables are not touching the SuperSprings. Secure any cables out of the way with zip ties or by re-routing. **Ensure all A/C lines, brake cables, and frame are clear of contact or interference.**

PART NUMBER

SSR-143-40-2

INSTALLATION

13. Place the lower bracket [ITEM D] on top of the factory leaf spring so that it straddles the factory top plate. Attach the bracket to the leaf pack using two u-bolts [ITEM F] and four flange nuts [ITEM G] and fasten them loosely.
14. Repeat steps 3 through 13 on the passenger side of the vehicle.
15. Once the installation on both sides is at this point, use a jack to raise the axle so the upper and lower halves of the SumoSprings are almost touching.
16. Using the adjustment slots, align the two halves of the SumoSprings so they sit vertically aligned.
17. With the driver's and passenger's sides aligned, tighten the u-bolt nuts securely without tightening to the point of bending the bracket. Torque the rest of the hardware to 25 ft. lbs.
18. Raise the vehicle to allow room to remove the safety jack stands.
19. Carefully lower vehicle to the hard surface and remove the blocks from the wheels.
20. Register the warranty for your SuperSprings International part. A warranty card can be found in the box your part came in.

Part Number: SSR-143-40-2

► Product Line: SUMOSPRINGS REAR

Page 3

SuperSprings International, Inc.

505 Maple Avenue
Carpenteria, CA 93013

Installation Support

+1 (800) 898-0705
support@supersprings.com

supersprings.com

SAFETY NOTICE: We recommend installation be done by a professional or persons with sound mechanical knowledge.

WARNING: These instructions are a general guide for installation. SuperSprings International, Inc. assumes no liability for the actual installation process. Consumers and installers should apply common automotive safety practices when raising and working on any vehicle. **Do not put yourself in a position where, if the vehicle were to move unexpectedly, you may be injured.** SuperSprings' products are designed to improve vehicle ride quality. Do not load any vehicle beyond the manufacturer's specifications.

Never exceed the manufacturer's Gross Vehicle Rating (GVWR) located on your vehicles identification tag.

BEFORE INSTALLATION: Ensure the vehicle is on a level surface, the parking brake is ON, with the ignition OFF, and place blocks in front of and behind the front tires to prevent the vehicle from moving.

DURING AND/OR AFTER INSTALLATION: Ensure emergency brake cables are not touching the SuperSprings. Secure any cables out of the way with zip ties or by re-routing. **Ensure all A/C lines, brake cables, and frame are clear of contact or interference.**