



INSTALLATION INSTRUCTIONS

HDX DROP STEP WTW

APPLICATION:

2010-2018 Dodge Ram 1500/2500/3500 Crew Cab 5ft & 6ft Bed

PART NUMBER: 56-534315, 56-534325, 56-5343152, 56-5343252

| ITEM | QUANTITY | DESCRIPTION | TOOLS NEEDED |
|-------|----------|---|----------------|
| 1,2 | 2 | STEP BAR, DRIVER (1) AND PASSENGER (2) | 10MM SOCKET |
| 3,4 | 2 | FRONT MOUNT BRACKET, DRIVER (3) AND PASSENGER (4) | 13MM SOCKET |
| 5,6 | 2 | CENTER MOUNT BRACKET, DRIVER (5) AND PASSENGER (6) | 13MM WRENCH |
| 7,8 | 2 | REAR MOUNT BRACKET DRIVER (7), AND PASSENGER (8) | SOCKET EXT. |
| 9,10 | 2 | ISOLATOR BRACKET, A (9) AND B (10) | ALLEN WRENCH |
| 11 | 2 | TOP ISOLATOR MOUNT BRACKET | RATCHET |
| 12 | 2 | ISOLATOR KIT | TORQUE WRENCH |
| 13 | 10 | M10 BOLT / M8 NUT PLATE | DRILL |
| 14 | 6 | M8 HEX RIV-CERT (YELLOW ZINC) | 1/2" DRILL BIT |
| 15 | 10 | M10 HEX NUT (YELLOW ZINC) | 18MM SOCKET |
| 16 | 10 | M10 SPLIT LOCK WASHER (YELLOW ZINC) | 19MM SOCKET |
| 17 | 10 | M10 FLAT WASHER (YELLOW ZINC) | 18MM WRENCH |
| 18 | 12 | M8 LONG HEX HEAD CAP SCREW (YELLOW ZINC) | 19MM WRENCH |
| 19 | 16 | M8 SHORT HEX HEAD CAP SCREW (YELLOW ZINC) | 15MM WRENCH |
| 20 | 28 | M8 SPLIT LOCK WASHER (YELLOW ZINC) | 15MM SOCKET |
| 21 | 28 | M8 FLAT WASHER (YELLOW ZINC) | 16MM WRENCH |
| 22 | 2 | M12 HEX HEAD CAP SCREW (YELLOW ZINC) | 16MM SOCKET |
| 23 | 2 | M12 SPLIT LOCK WASHER (YELLOW ZINC) | PRY TOOL |
| 24 | 6 | M6 BUTTON HEAD CAP SCREW (BLACK ZINC) | |
| 25 | 6 | M6 SERRATED FLANGE NUT (BLACK ZINC) | |
| 26 | 6 | M6 FLAT WASHER (BLACK ZINC) | |
| 27 | 6 | PLASTIC RETAINER SQUARE | |
| 28 | 2 | M10 FISH WIRE | |
| 29,30 | 2 | DRIVER SIDE DRILL TEMPLATE (29), AND PASSENGER (30) | |

ANTI-SEIZE LUBRICANT MUST BE USED ON ALL STAINLESS STEEL FASTENERS TO PREVENT THREAD DAMAGE AND GALLING

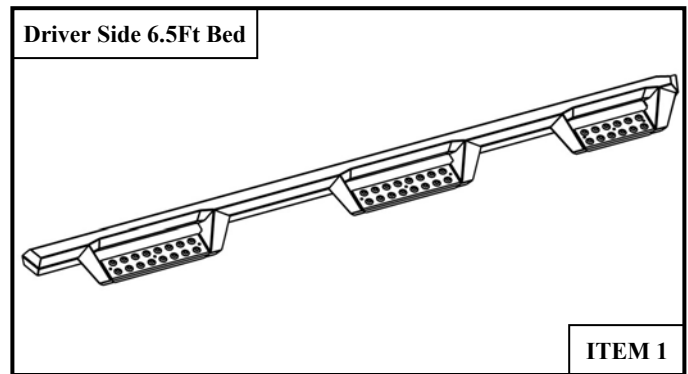
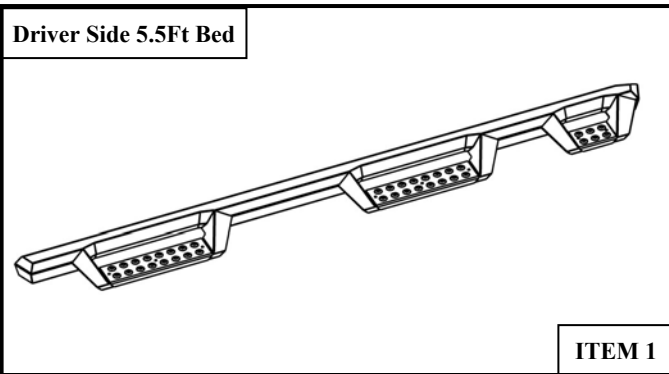

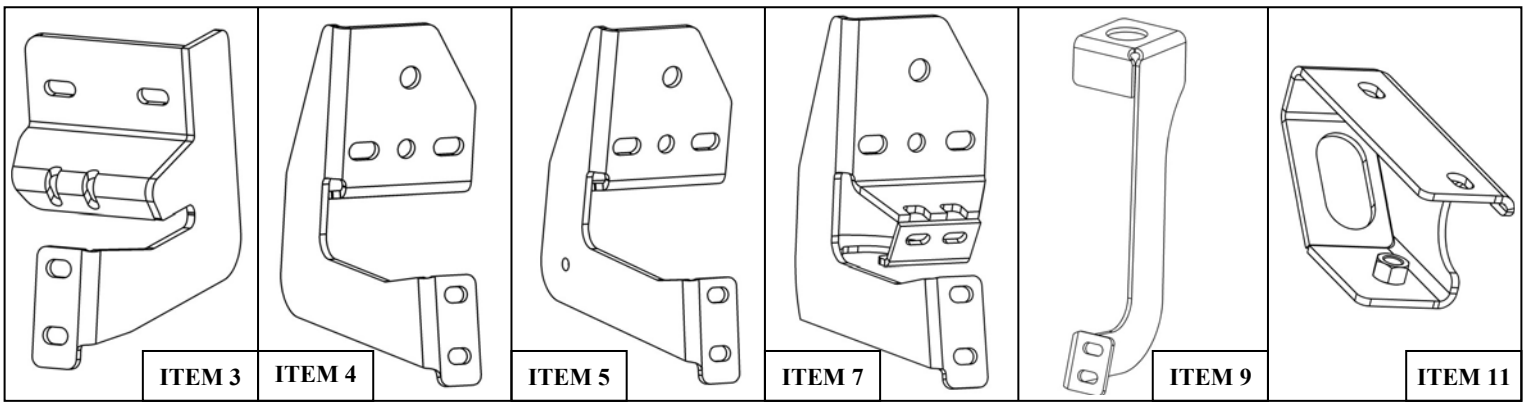

PROCEDURE

1. Remove contents from box, verify if all parts listed are present and free from damage. Carefully read and understand all instructions before attempting installation.
Failure to identify damage before installation could lead to a rejection of any claim.
2. Check either side of the vehicles rocker panel, locate the factory holes in the rocker panel by removing the tape. Check and verify what type of rocker panel you have. See **Figures 1, 2, 3, & 4.** **Note:** If any of the locations on the factory holes in the rocker panel have factory M8 riv-certs or threaded M8 holes, do not use provided M8 riv-certs (Item 14) at that location. Refer to **Figures 1, 2, & 4.**

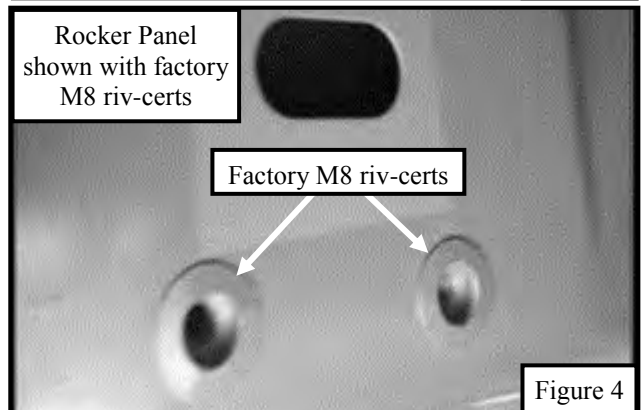
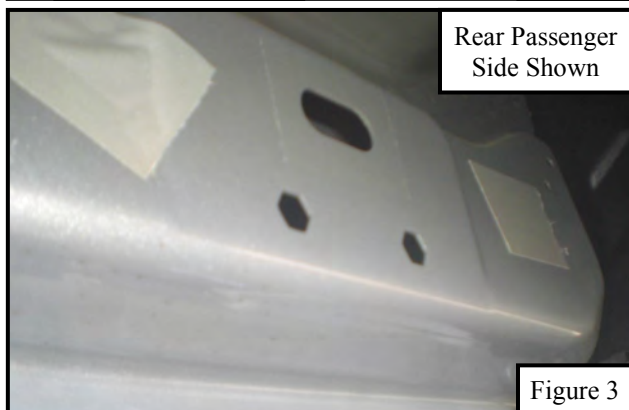
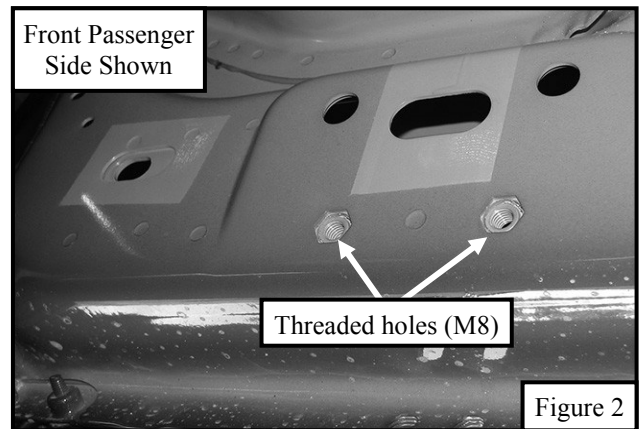
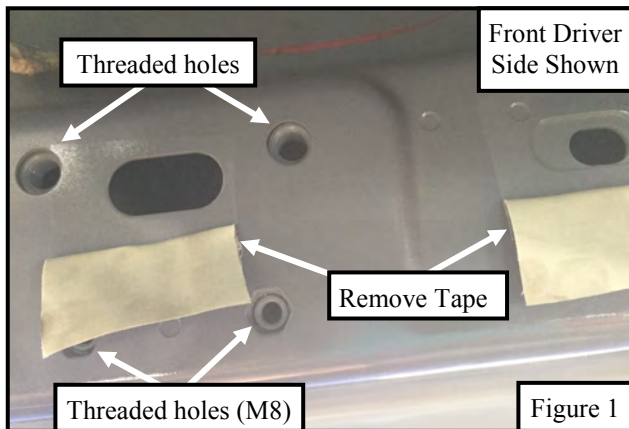

3. **Starting from the driver side:** If the threaded holes or threaded holes are not present use (1) M8 riv-certs (Item 14) and insert one into the either hex hole. Insert (1) M10 bolt / M8 nut plate (Item 13) and secure using (1) plastic retainer square (Item 27). See **Figure 5**. **Note:** See **Figure 6** for example on how to tighten M8 riv-certs, it will require to use an M10 bolt with M8 nut plate (Item 13) along with a bracket to perform this task. This procedure will permanently install M8 riv-cert. Repeat **step 3** for every bracket, except for the isolator bracket.

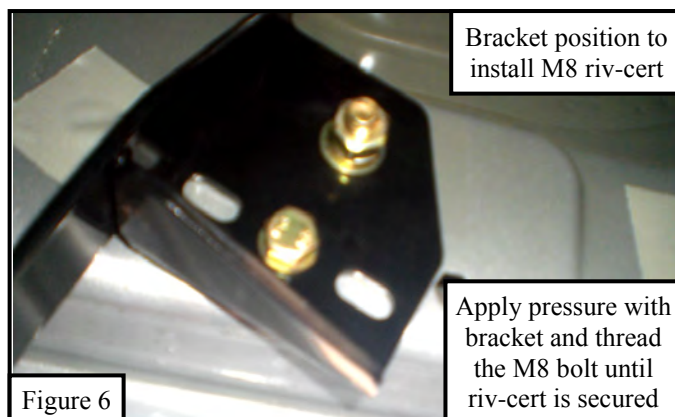
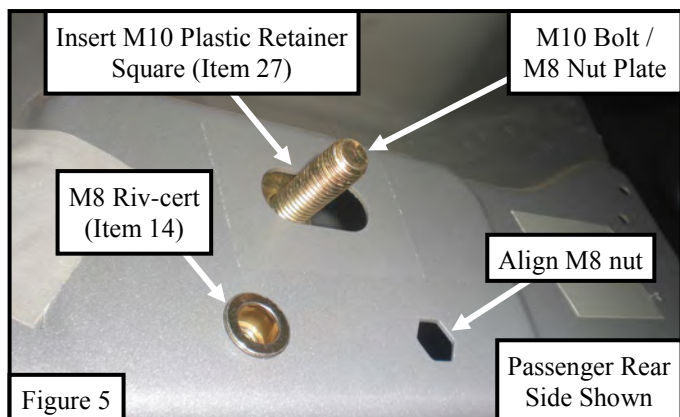

FOR NEWER MODELS: If the rocker panel has pre-installed M8 riv-certs or threaded holes, the M10 bolt / M8 nut plate will need to be positioned as shown in **Figure 8**.

FOR OLDER MODELS: If the rocker panel does not have pre-installed M8 riv-certs or threaded holes then will be used as shown on **Figures 5 & 11**.

4. Proceed to install the front driver mount bracket (Item 3) and the rear mount bracket (Item 7/8) onto the rocker panel by using (2) long M8 hex cap screws, (2) M8 lock washers, (2) M8 flat washers. For the pinch weld, attach bracket by using the provided black zinc M6 hardware. See **Figures 9, 10, and 12**.

Note: Drilling of two 1/4" holes might be necessary on pinch weld if factory holes are not present. Before drilling place masking tape on drill surface to prevent paint chipping.

5. Loosely secure the center bracket (Items 5/6) to the rocker panel in the center mounting locations using (2) long M8 hex bolts, (2) M8 lock washers, (2) M8 flat washers, (1) M10 flat washer, (1) M10 lock washer, and (1) M10 hex nut. Leave everything loose at this time. See **Figures 7 & 11**.
6. Repeat **Steps 3 - 5** for the passenger side. **Note:** Front passenger bracket installs same as center brackets (**Step 5**).
7. See **page 5** for view of bracket orientation.

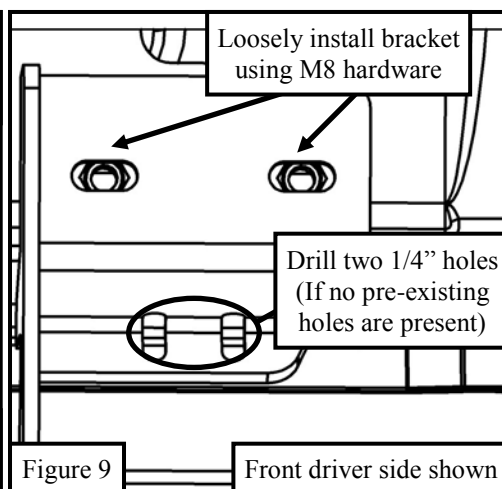
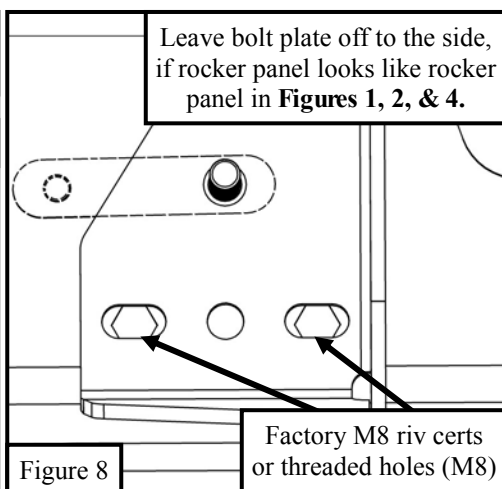
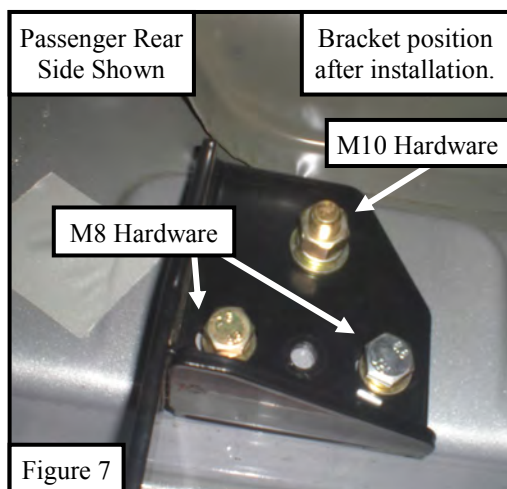

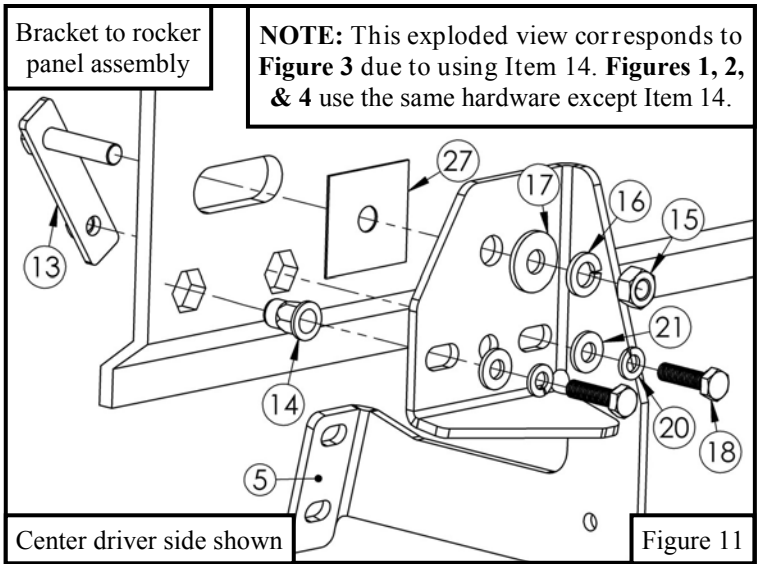
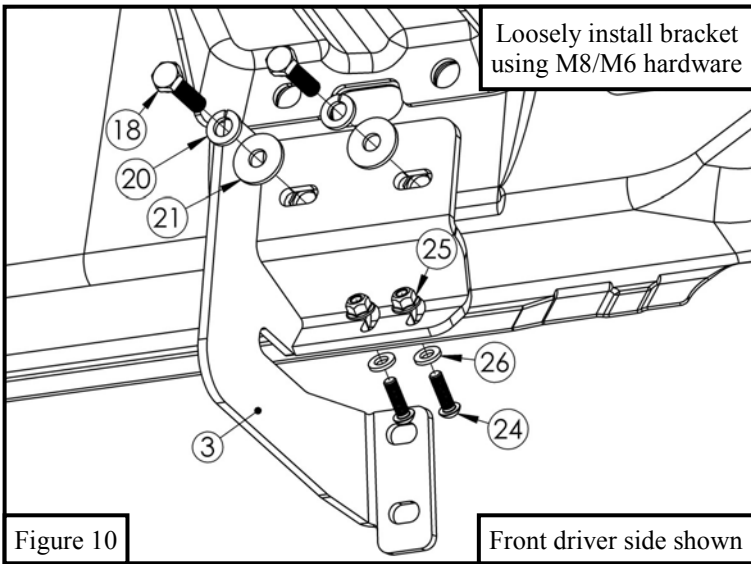

8. On either side of the vehicle, directly behind the cab, underneath the bed locate the bed rail. Grab the Drill Template (Item 29) and align it with the bed rail and the thin bed wall. Use a center drill bit to start the 2 holes. Then drill out 2 (1/2") holes using a 1/2" drill bit. Repeat on Passenger Side with (Item 30). See **Figure 13**.

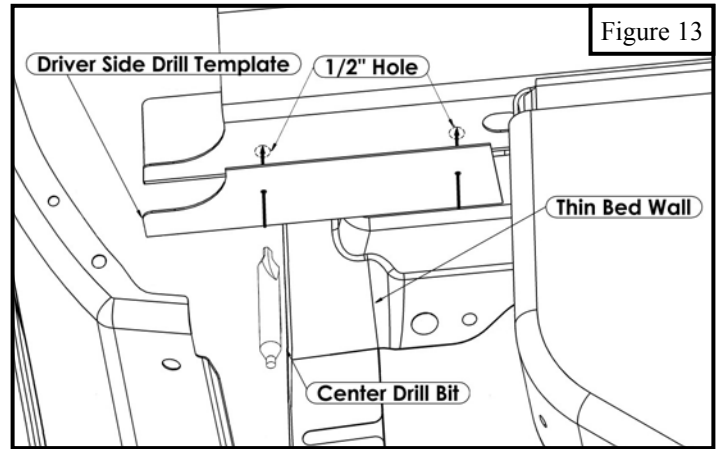
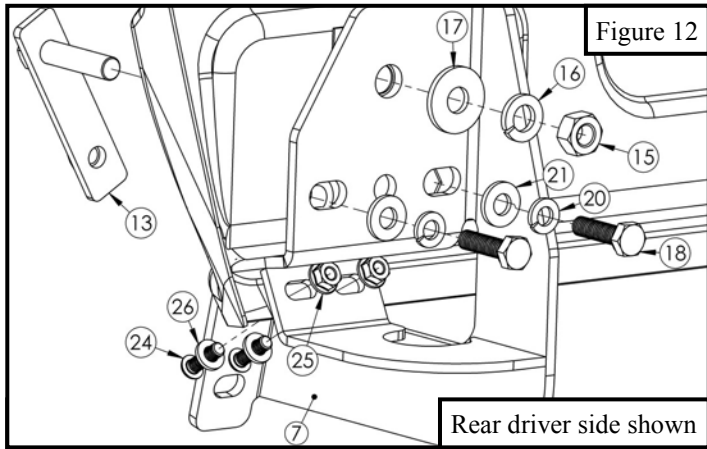

9. Locate (1) M10 fish wire (Item 28) and fish (1) M10 bolt / M8 nut plate (Item 13) through the rear drilled hole. Once bolt plates are placed, loosely install the Top Isolator Bracket (Item 11) with the supplied M10 hardware. (**Note:** Items 11 and 12 are identical). See **Figure 14**.

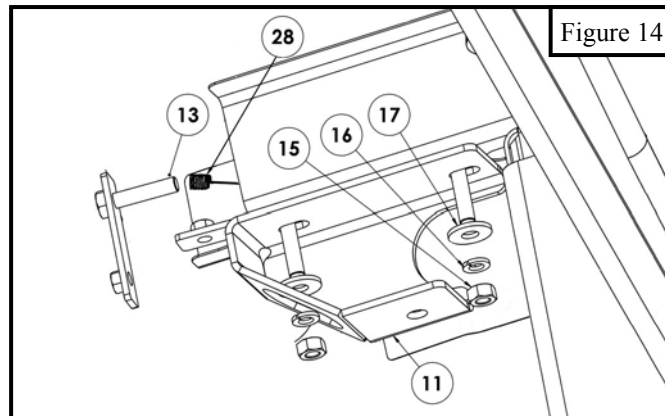

10. Locate (1) isolator kit (Item 12) and (1) isolator bracket (9/10) and loosely secure each other with the top isolator bracket. See **Figure 15**. (Note: See bracket orientation below and on pg.6)

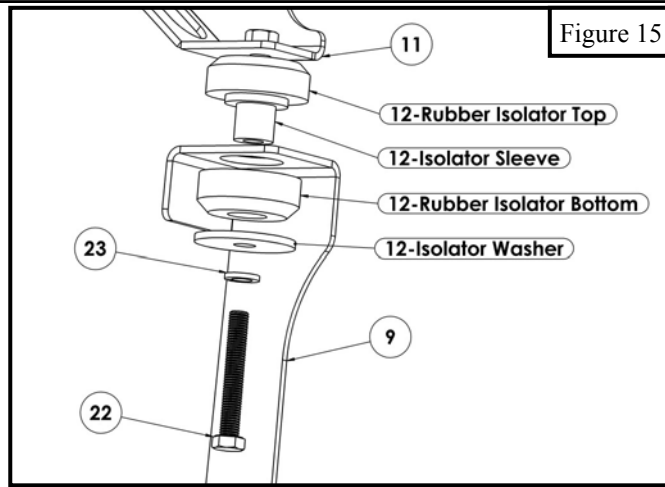

11. Repeat **Steps 8 - 11** for opposite side.
12. When installing brackets to board, tilt at angle. See **Figure 16**.
13. For Step Board installation to the previously installed mounting brackets use long M8 bolts and supplied M8 hardware on items 9 and 10. Use short M8 bolts and supplied M8 hardware on all other mount locations. See **Figure 17**.
14. Align and adjust the step bars and brackets as needed, then tighten all hardware: M10 to 30-35 ft-lbs, M8 to 15-18 ft-lbs, and M12 to 50-55 ft-lbs.

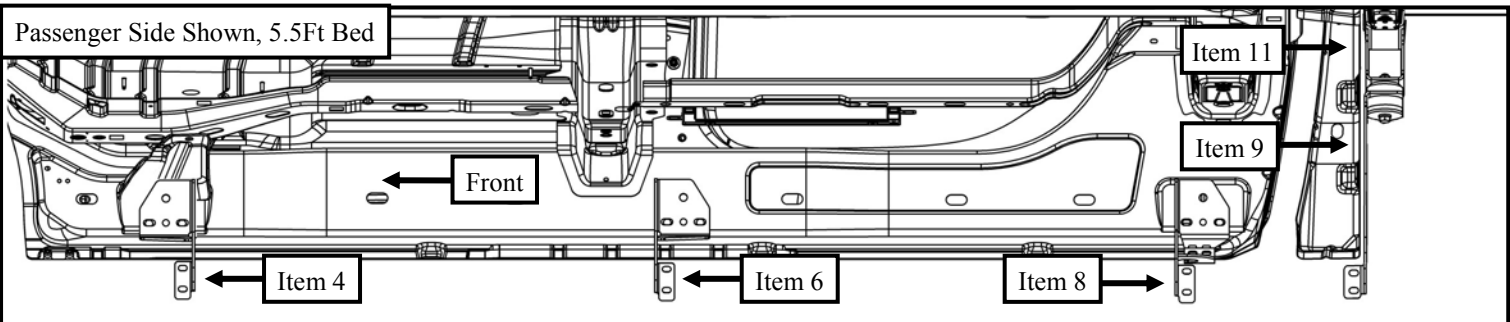
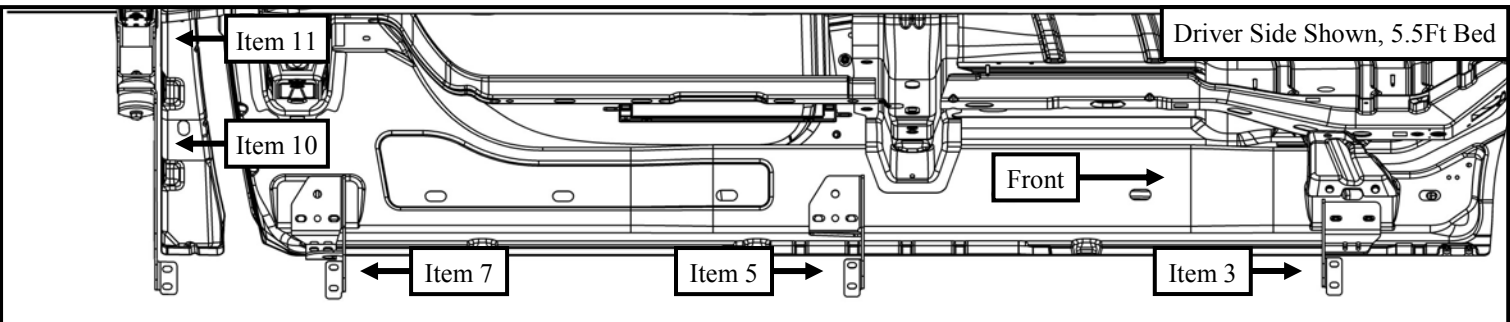
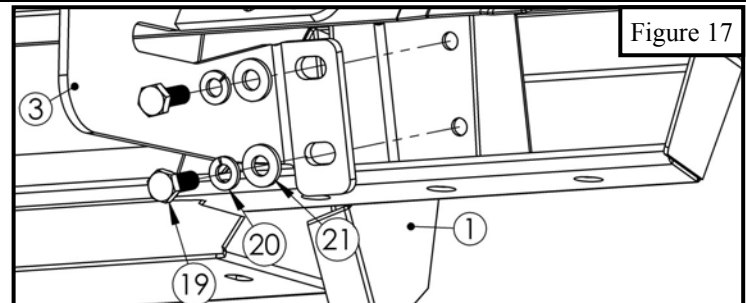
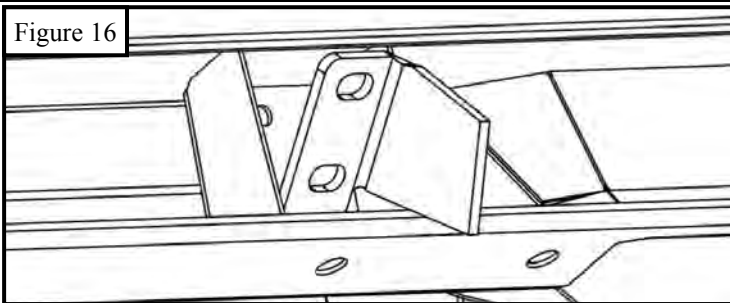

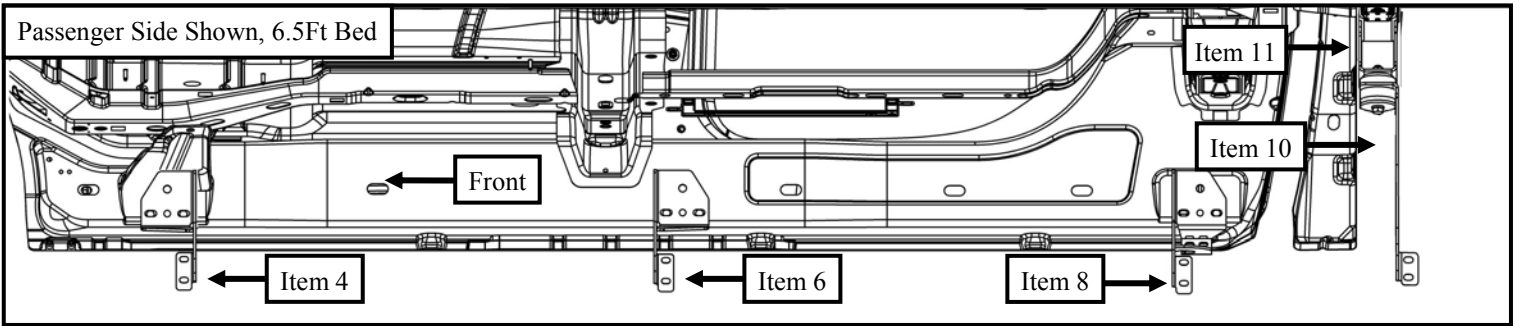
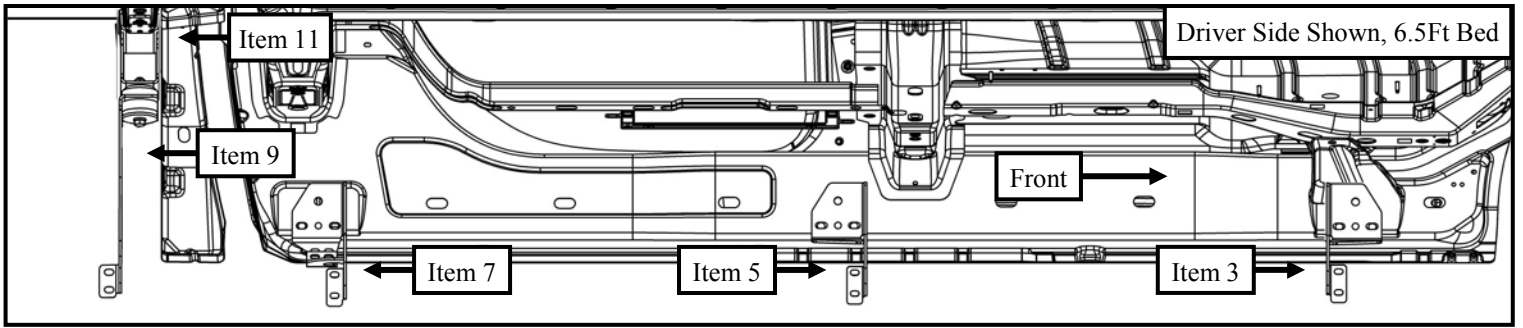

CARE INSTRUCTIONS

- REGULAR WAXING IS RECOMMENDED. DO NOT USE ANY TYPE OF POLISH OR WAX THAT MAY CONTAIN ABRASIVES.
- STAINLESS STEEL PRODUCTS CAN BE CLEANED WITH MILD SOAP AND WATER. STAINLESS STEEL POLISH SHOULD BE USED TO POLISH SMALL SCRATCHES.
- GLOSS BLACK FINISHES SHOULD BE CLEANED WITH MILD SOAP AND WATER.

WESTIN Westin Automotive Products, Inc.
320 W. Covina Blvd
San Dimas, Ca. 91773

Thank you for choosing Westin products
for additional installation assistance please call
Customer Service (800) 793-7846
www.westinautomotive.com



WARNING



Failure to follow these instructions could lead to death, personal injury, and / or property damage.

FASTENERS:

All Westin supplied fasteners must be utilized and installed in accordance with the installation instructions and apply torque to the specifications as defined. **DOUBLE CHECK ALL FASTENERS BEFORE INITIAL USE, AND PERIODICALLY IN THE FUTURE TO ENSURE PROPER FUNCTION AND SAFETY.**

DRILLING:

Most Westin products do not require drilling for installation. If drilling is defined as required, use caution when drilling a vehicle. **FAILURE TO REVIEW AN AREA TO BE DRILLED MAY RESULT IN PERSONAL INJURY AND/OR INJURY TO OTHERS AS WELL AS VEHICLE DAMAGE.**

EYE PROTECTION:

ALWAYS WEAR SAFETY GLASSES OR GOGGLES DURING THE INSTALLATION PROCESS TO AVOID PERSONAL INJURY.

MAXIMUM TOWING/CARRYING CAPACITY:

The Westin Receiver Hitches will have a visible tow rating label affixed directly on the product. User should never exceed the vehicle manufacturers maximum tow and weight rating regardless of the capacity of the hitch. **FAILURE TO FOLLOW THESE GUIDELINES WILL VOID THE WESTIN WARRANTY AND MAY RESULT IN PERSONAL INJURY AND/OR INJURY TO OTHERS AS WELL AS VEHICLE DAMAGE.**